

AUO-General



## CUSTOMER APPROVAL SHEET

<b>Company Name</b>	
<b>MODEL</b>	C090EAN04.1
<b>CUSTOMER APPROVED</b>	Title :  Name :

- APPROVAL FOR SPECIFICATIONS ONLY (Spec. Ver. 0.0)
- APPROVAL FOR SPECIFICATIONS AND ES SAMPLE (Spec. Ver. 0.0)
- APPROVAL FOR SPECIFICATIONS AND CS SAMPLE (Spec. Ver. 0.0)
- CUSTOMER REMARK :

1 Li-Hsin Rd. 2. Science-Based Industrial Park  
Hsinchu 300, Taiwan, R.O.C.  
Tel: +886-3-500-8800  
Fax: +886-3-577-2730

ALL RIGHTS STRICTLY RESERVED. ANY PORTION OF THIS PAPER SHALL NOT BE REPRODUCED, COPIED, OR TRANSFORMED TO ANY OTHER FORMS WITHOUT PERMISSION FROM AU OPTRONICS CORP.

AUO-General



Doc. Version	1
Total Page	24
Date	2018/8/30

## Product Specification

### 9.0" COLOR TFT-LCD MODULE

**MODEL NAME: C090EAN04.1**

< ◆ > Preliminary Specification

< > Final Specification

Note: The content of this specification is subject to change.

© 2016 AU Optronics  
All Rights Reserved,  
Do Not Copy.

ALL RIGHTS STRICTLY RESERVED. ANY PORTION OF THIS PAPER SHALL NOT BE REPRODUCED, COPIED, OR TRANSFORMED TO ANY OTHER FORMS WITHOUT PERMISSION FROM AU OPTRONICS CORP.



# Contents

<b>A.</b>	<b><u>General Description</u></b> .....	<b>5</b>
<b>B.</b>	<b><u>Features</u></b> .....	<b>5</b>
<b>C.</b>	<b><u>Physical Specifications</u></b> .....	<b>6</b>
	1. TFT LCD Panel.....	6
<b>D.</b>	<b><u>Outline Dimension</u></b> .....	<b>7</b>
	1. TFT-LCD Module.....	7
<b>E.</b>	<b><u>Electrical Specifications</u></b> .....	<b>8</b>
	1. TFT LCD Panel Pin Assignment.....	8
	2. Differential Input Data Format.....	10
	a. VESA format(DE Mode).....	10
<b>3.</b>	<b><u>Input Timing Diagram</u></b> .....	<b>11</b>
	4. Absolute Maximum Ratings.....	12
	5. DC Electrical Characteristics.....	12
	a. Power Specification.....	12
	a. Signal DC Electrical Characteristics.....	12
<b>b.</b>	<b><u>Backlight Driving Conditions (Note 1)</u></b> .....	<b>14</b>
	6. AC Electrical Characteristics.....	15
<b>a.</b>	<b><u>Input AC characteristics</u></b> .....	<b>15</b>
<b>b.</b>	<b><u>Differential signal AC characteristics</u></b> .....	<b>15</b>
	8. Power on/off sequence.....	16
<b>a.</b>	<b><u>Power on sequence:</u></b> .....	<b>16</b>
<b>b.</b>	<b><u>Power Off sequence:</u></b> .....	<b>17</b>
<b>c.</b>	<b><u>VDD off to on timing</u></b> .....	<b>17</b>
<b>E.</b>	<b><u>Optical specifications (Note 1, 2)</u></b> .....	<b>18</b>
<b>G.</b>	<b><u>Reliability Test Items(Note 1~3)</u></b> .....	<b>21</b>
<b>H.</b>	<b><u>Quality Spec</u></b> .....	<b>22</b>
<b>I.</b>	<b><u>Packing and Marking</u></b> .....	<b>23</b>
	1. Packing Form.....	23
	2. Module/Panel Label Information.....	24
	3. Carton Label Information.....	24



Version 4

Page: 5/24

## A. General Description

C090EAN04.1 is a a-Si type Thin Film Transistor Liquid crystal Display (TFT-LCD) with AHVA (Advanced Hyper-Viewing Angle) technology. This model is composed of a TFT-LCD, driver ICs, FPC (flexible printed circuit), and a backlight unit.

## B. Features

- 9.0"-inch display
- 1280 x 720 RGB resolution in RGB stripe dot arrangement
- High brightness
- Interfaces: LVDS ( 8bit JEIDA, DE mode)
- AHVA – wide view technology
- RoHS compliance

ALL RIGHTS STRICTLY RESERVED. ANY PORTION OF THIS PAPER SHALL NOT BE REPRODUCED, COPIED, OR TRANSFORMED TO ANY OTHER FORMS WITHOUT PERMISSION FROM AU OPTRONICS CORP.

AUO-General

AUO-General

## C. Physical Specifications

### 1. TFT LCD Panel

NO.	Item	Unit	Specification	Remark
1	Display Resolution	dot	1280 (H)x 720(V) RGB	
2	Active Area	mm	198.72 (H) x 111.78 (V)	
3	Screen Size	inch	9.0(Diagonal)	
4	Dot Pitch	$\mu\text{m}$	51.75 (R.G.B) x 155.25 (V)	
5	Color Configuration	—	R. G. B. Stripe	
6	Color Depth	—	16.7 M colors	
7	Overall Dimension	mm	212.2x127.9x7.6	w/o Boss
8	Weight	g	TBD+/- 10%	
9	Display Mode	—	Normally Black	
10	Surface Treatment	—	AG	

**Note 1:** Below figure shows dot stripe arrangement.

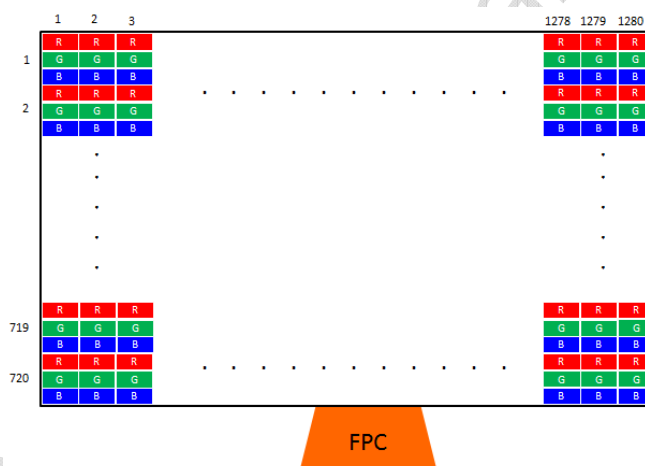

**Note 2:** Below figure shows dot stripe arrangement.

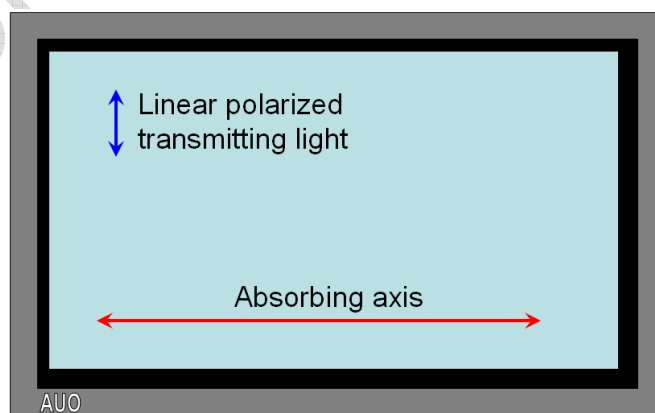



### D. Outline Dimension 1. TFT-LCD Module

(Drawing is temporary, Need further discussion with Tier1)

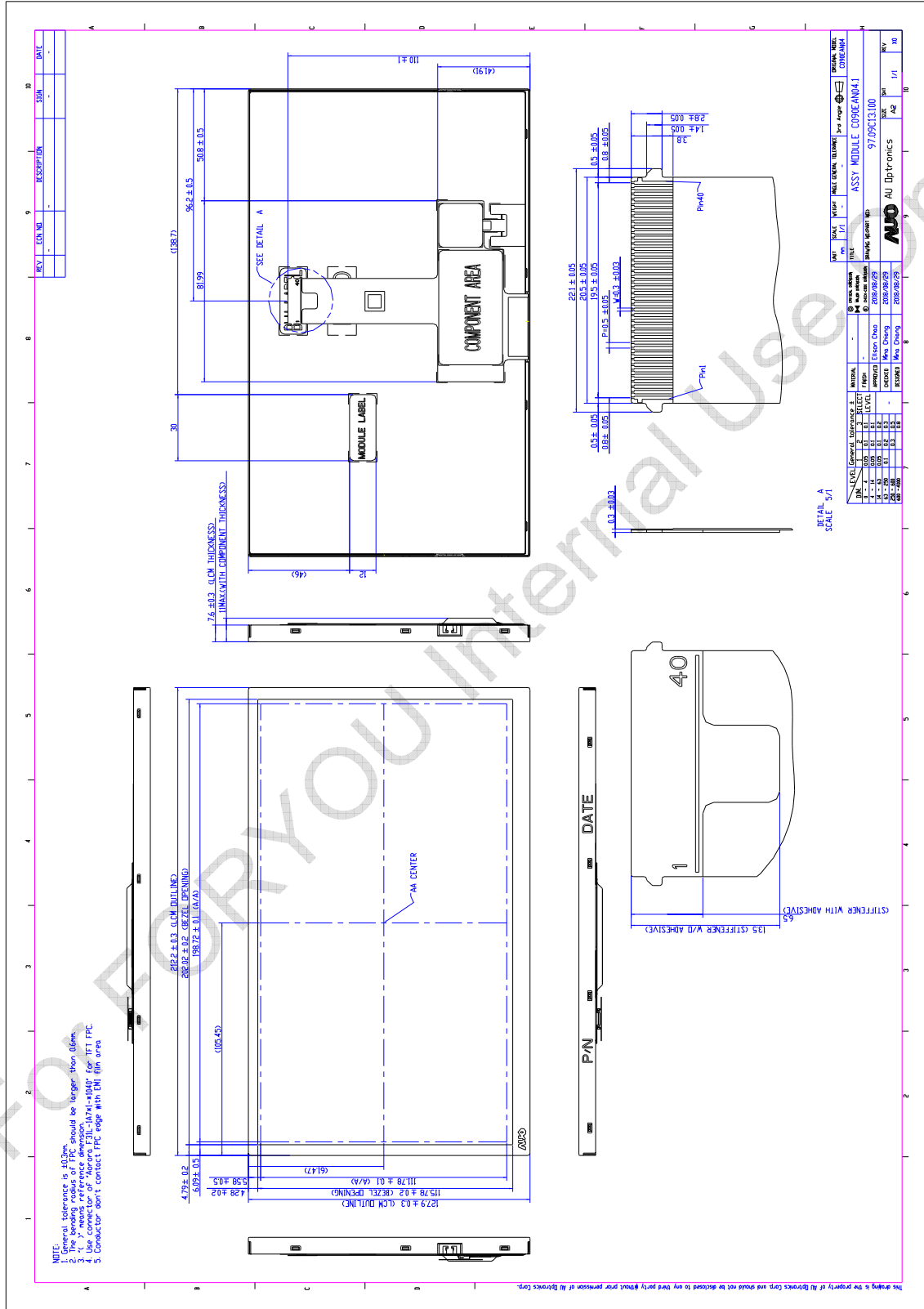

ALL RIGHTS STRICTLY RESERVED. ANY PORTION OF THIS PAPER SHALL NOT BE REPRODUCED, COPIED, OR TRANSFORMED TO ANY OTHER FORMS WITHOUT PERMISSION FROM AU OPTONICS CORP.

AUO-General

AUO-General



## E. Electrical Specifications

### 1. TFT LCD Panel Pin Assignment

Recommended Connector:

No.	Pin Name	I/O	Description	Remarks
1	GND	G	Ground.	
2	GND	G	Ground.	
3	PIND3	I	Positive LVDS differential input.	
4	NIND3	I	Negative LVDS differential input.	
5	GND	G	Ground.	
6	CLKP	I	Positive LVDS differential clock input.	
7	CLKN	I	Negative LVDS differential clock input.	
8	GND	G	Ground.	
9	PIND2	I	Positive LVDS differential input.	
10	NIND2	I	Negative LVDS differential input.	
11	GND	G	Ground.	
12	PIND1	I	Positive LVDS differential input.	
13	NIND1	I	Negative LVDS differential input.	
14	GND	G	Ground.	
15	PIND0	I	Positive LVDS differential input.	
16	NIND0	I	Negative LVDS differential input.	
17	GND	G	Ground.	
18	NC/CS		Dummy	NC,AUO test pin
19	NC/SCL		Dummy	NC,AUO test pin
20	NC/SDO		Dummy	NC,AUO test pin
21	NC/SDI		Dummy	NC,AUO test pin
22	GND	G	Ground.	
23	NC		Dummy	
24	VDD	PI	Digital power supply voltage.	
25	VDD	PI	Digital power supply voltage.	
26	VDD	PI	Digital power supply voltage.	
27	VDD	PI	Digital power supply voltage.	
28	NC/VPP		Dummy	NC,AUO test pin
29	GND	G	Ground.	
30	GND	G	Ground.	
31	TH-		Thermistor-	
32	TH+		Thermistor+	
33	CATHODE1		Power Supply for LED circuit(CATHODE1)	
34	CATHODE2		Power Supply for LED circuit(CATHODE2)	

ALL RIGHTS STRICTLY RESERVED. ANY PORTION OF THIS PAPER SHALL NOT BE REPRODUCED, COPIED, OR TRANSFORMED TO ANY OTHER FORMS WITHOUT PERMISSION FROM AU OPTRONICS CORP.

AUO-General

AUO-General



35	CATHODE3		Power Supply for LED circuit(CATHODE3)	
36	NC		Dummy	
37	NC		Dummy	
38	ANODE1		Power Supply for LED circuit(ATHODE1)	
39	ANODE2		Power Supply for LED circuit(ATHODE2)	
40	ANODE3		Power Supply for LED circuit(ATHODE3)	

I: Digital signal input, O: Digital signal output, G: GND, PI: Power input

ALL RIGHTS STRICTLY RESERVED. ANY PORTION OF THIS PAPER SHALL NOT BE REPRODUCED, COPIED, OR TRANSFORMED TO ANY OTHER FORMS WITHOUT PERMISSION FROM AU OPTRONICS CORP.

**AUO-General**

**AUO-General**

## 2. Differential Input Data Format

### a. JEIDA format(DE Mode)

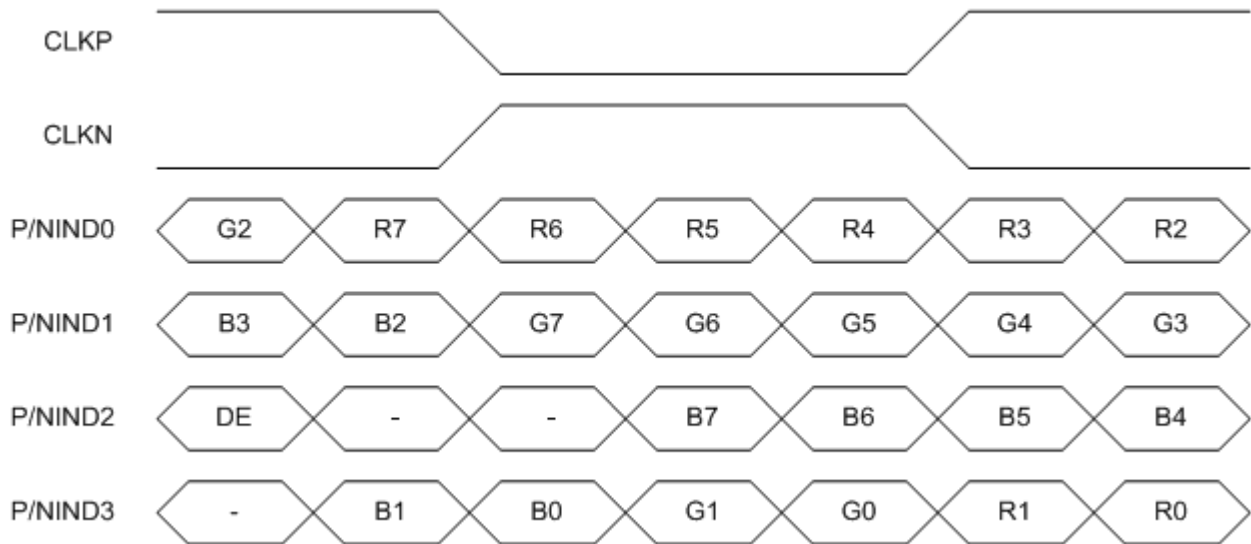

Fig. 1. LVDS input data JEIDA format

### 3. Input Timing Diagram

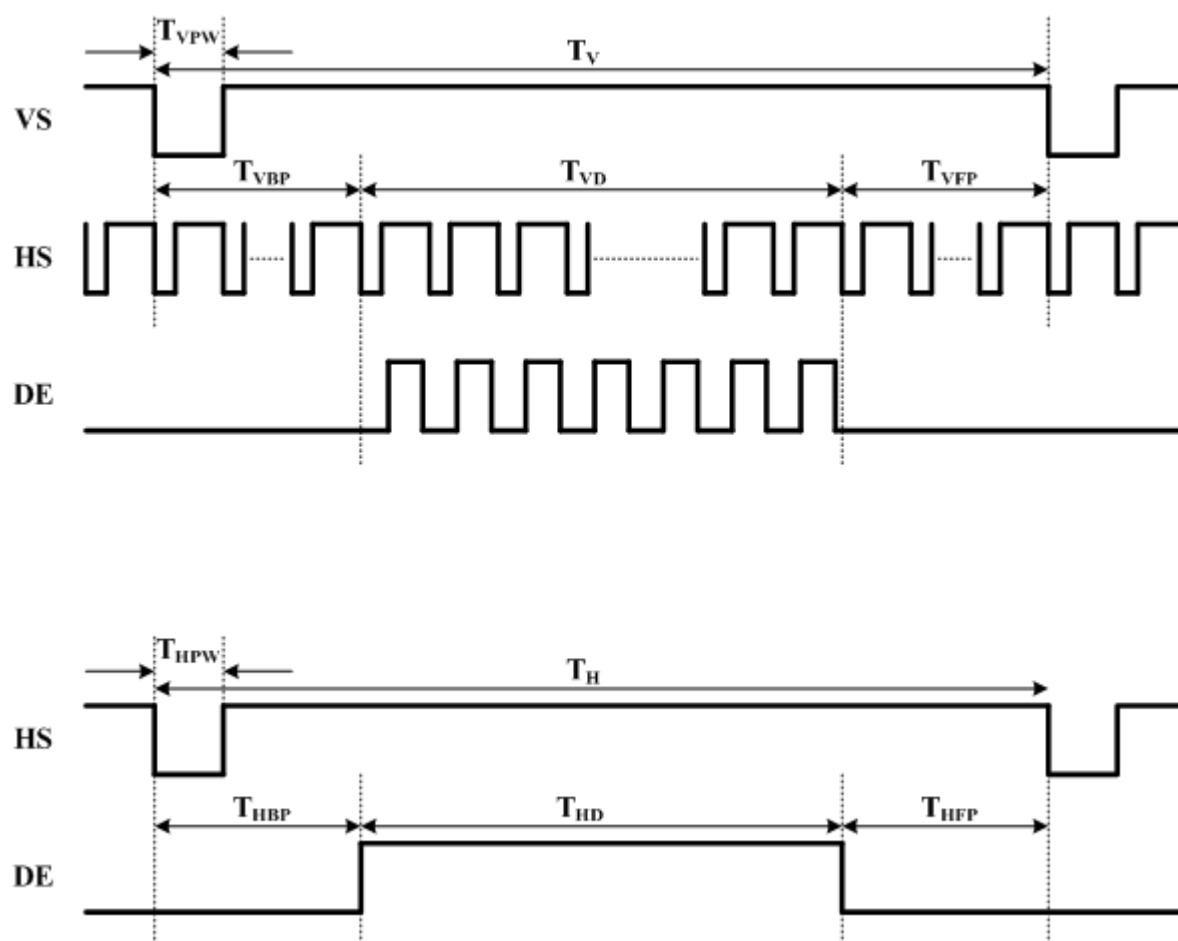

Fig. 2. Input Timing Diagram

#### DE Mode

Parameter	Symbol	Min.	Typ.	Max.	Unit.	Remark
<b>CLK Frequency</b>	$F_{CLK}$	66.03	71.15	80.08	MHz	
<b>HSYNC</b>	Period	$T_H$	1448	1540	1612	CLK
	Horizontal display area	$T_{HD}$	1280			CLK
	Blanking	$T_{HBP} + T_{HFP}$	168	260	332	CLK
<b>VSYNC</b>	Period	$T_V$	760	770	828	HS
	Vertical display area	$T_{VD}$	720			HS
	Blanking	$T_{VBP} + T_{VFP}$	40	50	108	HS

ALL RIGHTS STRICTLY RESERVED. ANY PORTION OF THIS PAPER SHALL NOT BE REPRODUCED, COPIED, OR TRANSFORMED TO ANY OTHER FORMS WITHOUT PERMISSION FROM AU OPTRONICS CORP.

AUO-General

AUO-General

#### 4. Absolute Maximum Ratings

Items	Symbol	Values		Unit	Condition
		Min.	Max.		
Power Voltage	VDD	-0.5	5	V	GND = 0V
Operation Temperature	Topa	-30	85	°C	Ambient
Storage Temperature	Tstg	-40	95	°C	Ambient

Note: Functional operation should be restricted under normal ambient temperature.

#### 5. DC Electrical Characteristics

The following items are measured under stable condition and suggested application circuit.

##### a. Power Specification

Parameter	Symbol	Min	Typ	Max	Unit	Notes
Power Supply	VDD	3.0	3.3	3.6	V	
	IVDD	-	128.3	312	mA	Note 3
	Inrush IVDD	-	-	451	mA	Note 4

Note 1: All conditions should be set typical value

Note 2: The panel can operate normally in the recommended operating condition.

Note 3: Test pattern is as the following picture..

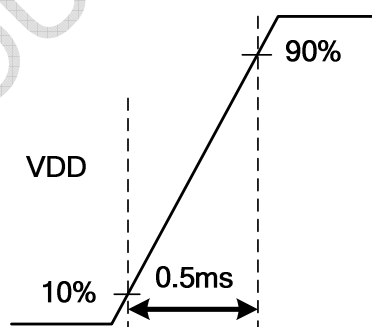

Fig1. Typical current situation



Fig2. Max current situation: Vertical stripe pattern alternating 0 gray scale with 255 gray scale every dot

Note 4: Test condition is the VDD voltage range between 3.3V on the rising time 0.5ms, Please see below picture.



##### a. Signal DC Electrical Characteristics

Parameter	Symbol	Min	Typ	Max	Unit	Notes
Input signal voltage	$V_i$	-0.3	-	VDD	V	Note1
Input high level voltage	$V_{IH}$	0.7VDD	-	VDD	V	Note1
Input low level voltage	$V_{IL}$	GND	-	0.3VDD	V	Note1
Differential input high threshold	$R_{XVTH}$	0.2	-	-	V	Note 2

ALL RIGHTS STRICTLY RESERVED. ANY PORTION OF THIS PAPER SHALL NOT BE REPRODUCED, COPIED, OR TRANSFORMED TO ANY OTHER FORMS WITHOUT PERMISSION FROM AU OPTRONICS CORP.

AUO-General

AUO-General

Differential input low threshold	$R_{XVTL}$	-	-	-0.2	V	Note 2
Input voltage range (singled-end)	$R_{XVIN}$	0	-	(VDD-1.2)	V	Note 2
Input differential voltage	$ V_{ID} $	0.15	-	0.6	V	Note 2
Differential Input Common Mode Voltage	$R_{XVCM}$	$ VID /2$	-	(VDD-1.2 - $ VID /2$ )	V	Note 2

Note 1: TTL interface signal DC characteristics

Note 2: LVDS interface signal DC characteristic

### Single-end Signal

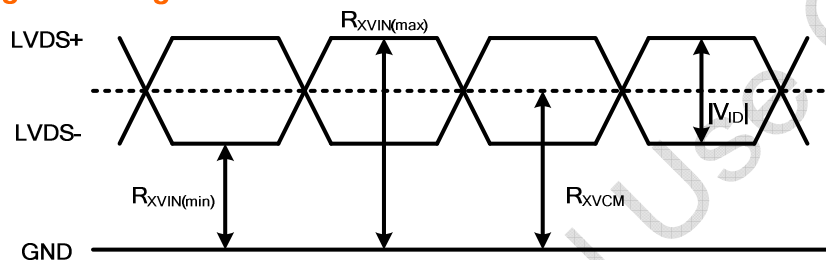

### Differential Signal

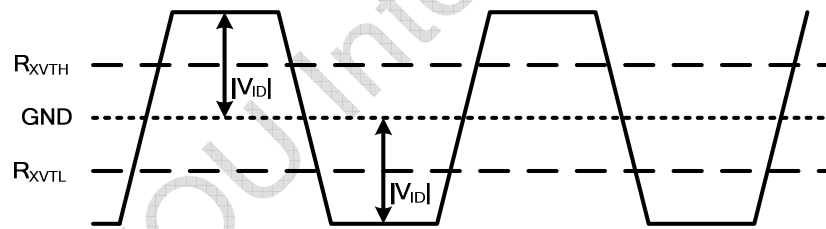

Fig. 3. LVDS DC characteristics diagram

### b. Backlight Driving Conditions (Note 1)

Parameter	Symbol	Min.	Typ.	Max.	Unit	Remark
LED Supply Current	$I_L$		80	85	mA	single serial (Note 3)
LED Supply Voltage	$V_L$			27.2	V	single serial (Note 3)
LED Life Time	$L_L$	10,000			hr	Note 2

Note 1: light-bar has 24 pieces of LED (3 strings, 8 pieces for each string).

Note 2: LED life time defining the 50% decreasing of the original brightness is 10,000 hours under the 80 mA of LED current in 25 °C..

Note 3: The LED supply power is for 3 string of LED.

Note 4: The voltage capacity of LED driver IC must be over max. of LED Voltage.

Fig. 4. Light bar structure

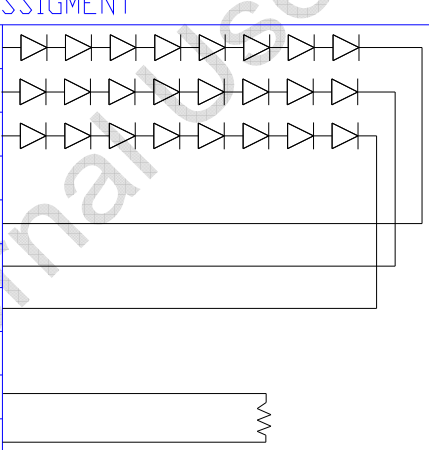
BACK LIGHT FPC PIN ASSIGMENT			
PIN1	LED 1,4,7,10,13,16,19,22	+1	
PIN2	LED 2,5,8,11,14,17,20,23	+2	
PIN3	LED 3,6,9,12,15,18,21,24	+3	
PIN4	NA		
PIN5	CATHODE	-1	
PIN6	CATHODE	-2	
PIN7	CATHODE	-3	
PIN8	NA		
PIN9	NTC+	+	
PIN10	NTC-	-	

## 6. AC Electrical Characteristics

### a. Input AC characteristics

Parameter	Symbol	Min.	Typ.	Max.	Unit	Remark
VDD power on slew time	$T_{POR}$	1	-	20	ms	From 0V to 90% VDD

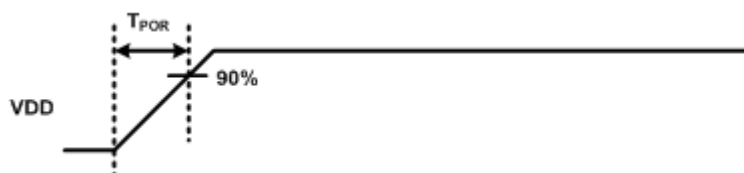

Fig. 6. VDD timing diagram

### b. Differential signal AC characteristics

Parameter	Symbol	Min.	Typ.	Max.	Unit	Remark
Clock frequency	$R_{XFCLK}$	66.03	71.15	80.08	MHz	
Input data skew margin	$T_{RSKM}$			400	ps	

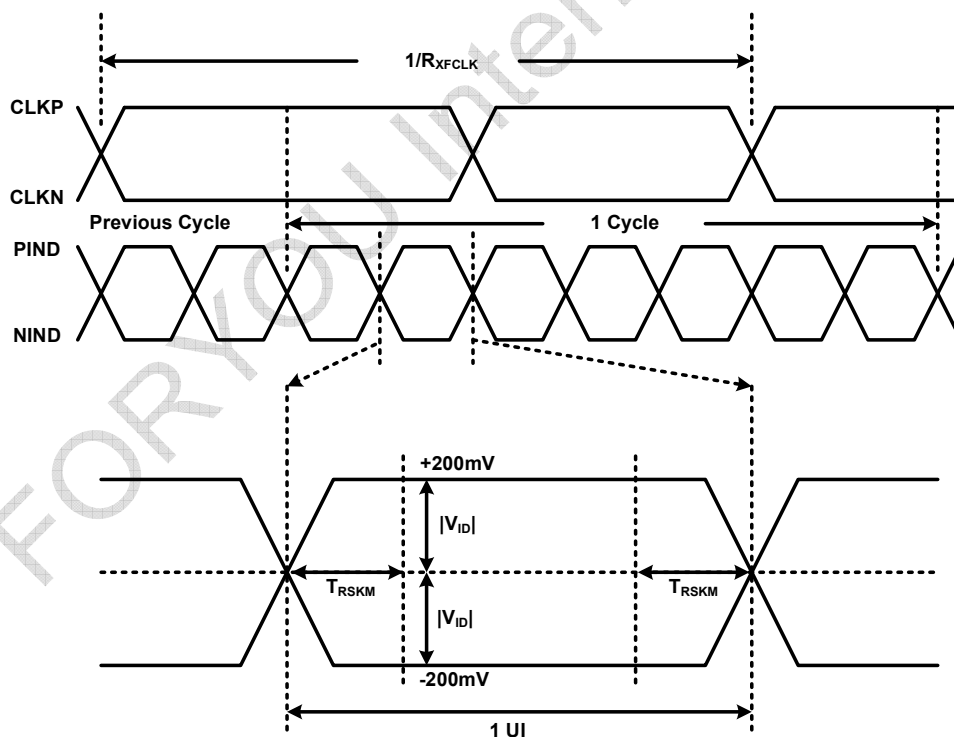

Fig. 7 LVDS AC characteristics diagram

## 8. Power on/off sequence

The LCD adopts high voltage driver IC, so it could be permanently damaged under a wrong power on/off sequence. The suggested LCD power sequence is below:

### a. Power on sequence:

VDD → LVDS → BKLEN

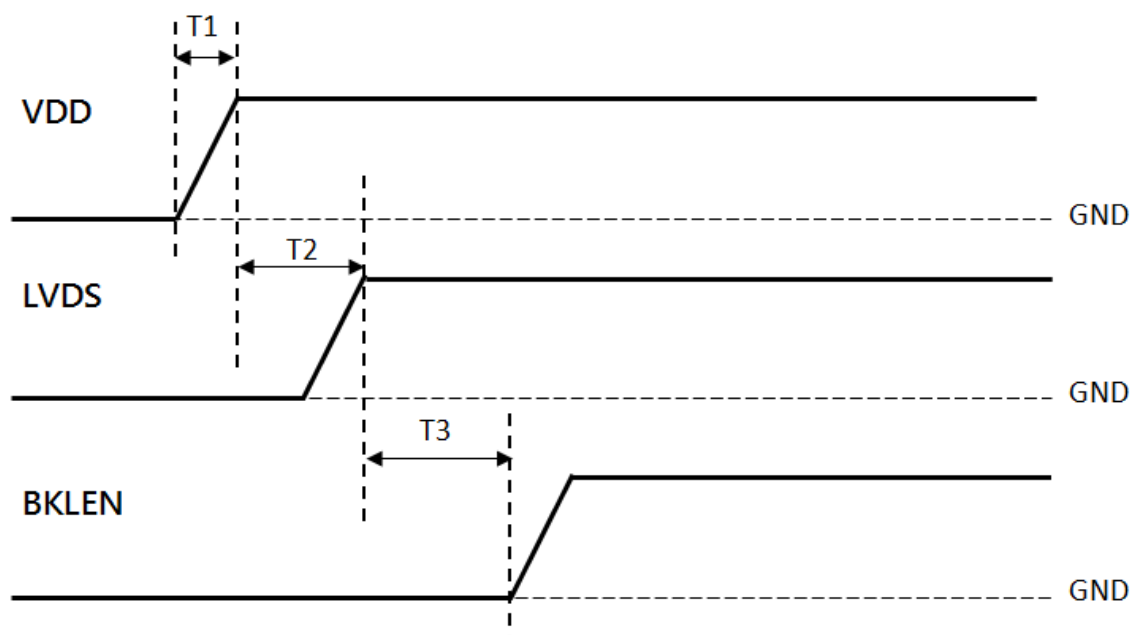

Fig. 8. Power on sequence (GND=0V)

### Power on timing:

Parameter	Value			Units
	Min.	Typ.	Max.	
T1	1	--	20	ms
T2	1	--	10	ms
T3	300	350	--	ms



**b. Power Off sequence:  
BKLEN → LVDS → VDD**

Fig. 9. Power off sequence (GND=0V)

**Power off timing:**

Parameter	Value			Units
	Min.	Typ.	Max.	
T1	90	100	--	ms
T2	1	--	10	ms
T3	1	--	10	ms

**c. VDD off to on timing**

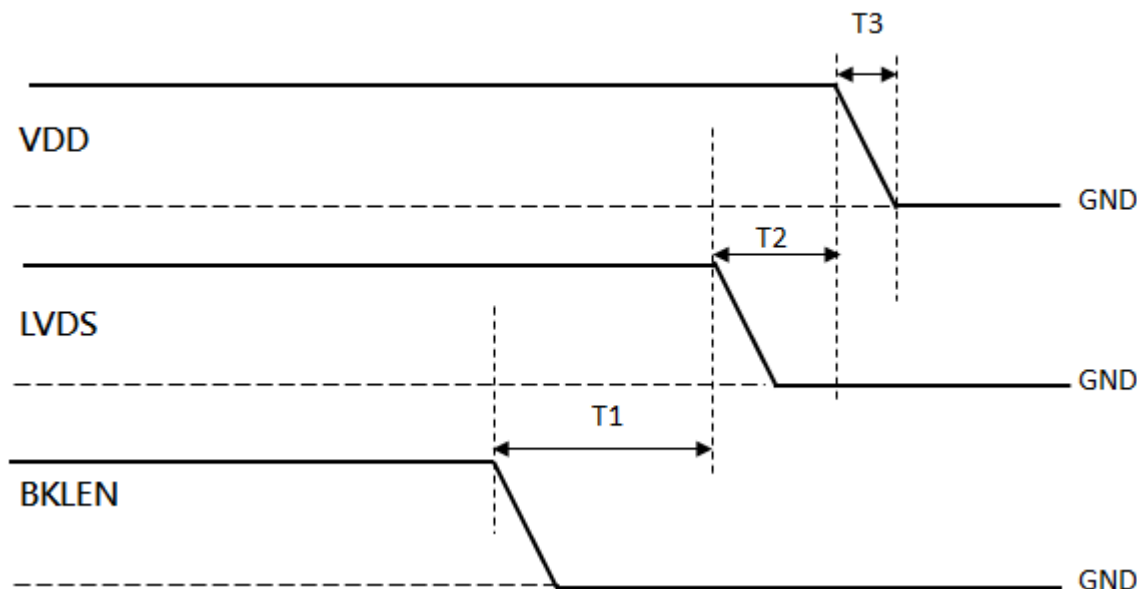
Parameter	Value			Unit	Remark
	Min.	Typ.	Max.		
T1	1		--	s	Note 1

Note 1 : Before VDD turns ON, please make sure that AVDD; VGH; VGL; are all below intensity of 0.1V.

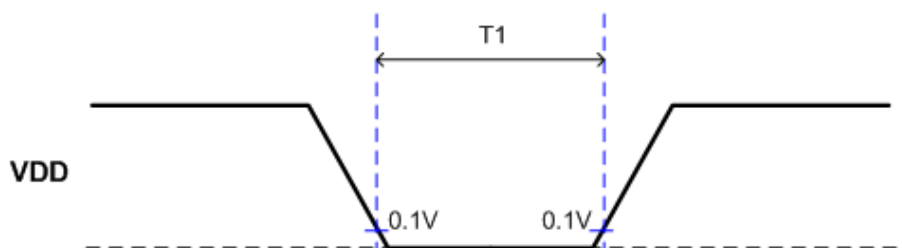

## F. Optical specifications (Note 1, 2)

Item	Symbol	Condition	Min.	Typ.	Max.	Unit	Remark
Response time (Rise + Fall)	Tr + Tf	$\theta=0^\circ$ at 25°C (Ta)	-	30	40	ms	Note 3
		$\theta=0^\circ$ at 0°C (Ta)	-	65	95	ms	
		$\theta=0^\circ$ at -20°C (Ta)	-	150	200	ms	
		$\theta=0^\circ$ at -30°C (Ta)	-	300	450	ms	
Viewing Angle Top Bottom Left Right	$\theta$	CR $\geq$ 10	70 70 70 70	80 80 80 80	-	deg.	Note 7, 8
Contrast ratio	CR1	$\theta=0^\circ$	700	1000	-		Note 4, 5, 6
Brightness	Y <sub>L</sub>	$\theta=0^\circ$	(770)	(900)	-	cd/m <sup>2</sup>	Note 1,2,9
White Chromaticity	X	$\theta = 0^\circ$	0.256	0.296	0.336		Note 10
	Y	$\theta = 0^\circ$	0.273	0.313	0.353		
Red Chromaticity	X	$\theta = 0^\circ$	0.600	0.640	0.680		
	Y	$\theta = 0^\circ$	0.293	0.333	0.373		
Green Chromaticity	X	$\theta = 0^\circ$	0.258	0.298	0.338		
	Y	$\theta = 0^\circ$	0.562	0.602	0.642		
Blue Chromaticity	X	$\theta = 0^\circ$	0.108	0.148	0.188		
	Y	$\theta=0^\circ$	0.018	0.058	0.098		
Uniformity		$\theta=0^\circ$	70			%	Note 11
NTSC				70		%	
Surface reflectance	R <sub>surf</sub> (SCI)	$\theta=0^\circ$			4.5	%	Note 12

Note 1: Measurement should be performed in the dark room, optical ambient temperature = 25 °C, and backlight current I<sub>L</sub> = 80mA.

Note 2: To be measured in the center area of TFT-LCD with a field angle of 1° by Topcon luminance meter SR3, after 10 minutes operation and warm up 30 minutes.

Note 3: Definition of response time:

The output signals of photo detector are measured when the input signals are changed from "black state" to "white state" (falling time) and from "white state" to "black state" (rising time), respectively.

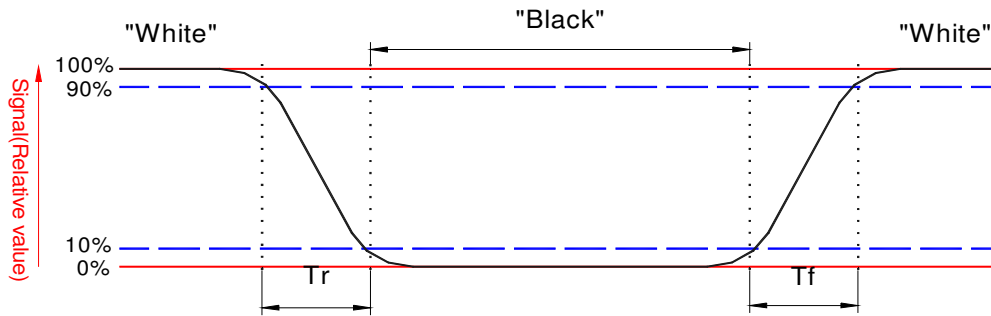

Note 4: Based on liquid crystal characteristics, the response time will become slower and the color of panel will become darker than the above optical specification when ambient temperature is below 25 °C.

Note 5: Contrast ratio is calculated with the following formula.

$$\text{Contrast ratio} = \frac{\text{Photo detector output when LCD is at "White" state}}{\text{Photo detector output when LCD is at "Black" state}}$$

Note 6: When "White" state, R[7:0]=G[7:0]=B[7:0]=11111111

When "Black" state, R[7:0]=G[7:0]=B[7:0]=00000000

Note 7: Definition of viewing angle: refer to figure as below.

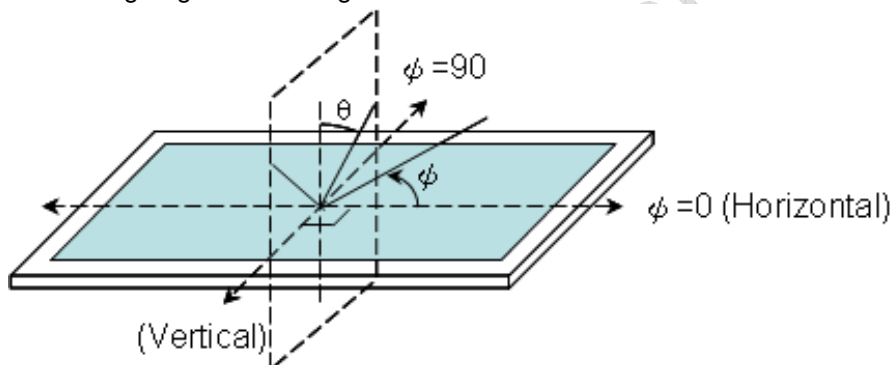

Note 8: Viewing angles are measured at the center of the panel when all the input terminals of LCD oanel are electrically opened.

Note 9: Brightness is measured at the center of the display.

Note 10: The viewing angles are measured at the center area of the panel when all the input terminals of LCD panel are electrically opened.

Note 11: Luminance Uniformity of these 9 points is defined as below: (1 : 4 : 4 : 1)

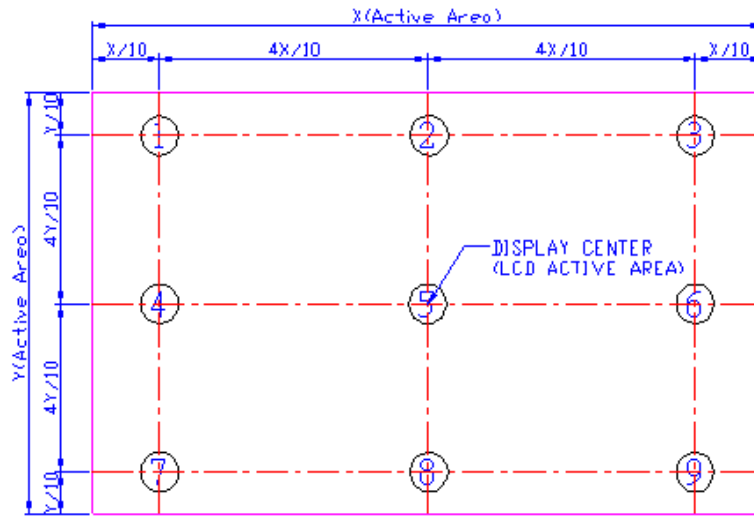

$$\text{Uniformity} = \frac{\text{minimum luminance in 9 points (1-9)}}{\text{maximum luminance in 9 points (1-9)}}$$

Note 12.

Measured on the center area of the LCD active area .

Measure equipment: SR3 or SR3A

For FORYOU Internal Use Only

### G. Reliability Test Items(Note 1~3)

No.	Test items	Conditions		Remark
1	High temperature storage	Ta= 95 °C	500 Hrs	
2	Low temperature storage	Ta= -40 °C	500 Hrs	
3	High temperature operation	Ta= 85 °C	500 Hrs	
4	Low temperature operation	Ta= -30 °C	500 Hrs	
5	High temperature and high humidity	Ta= 60 °C, 90 % RH	500 Hrs	Operation
6	Heat shock	-30 °C ~ 85 °C / 200 cycles 1 Hrs/cycle		Non-operation
7	Shock	100 G, 6 ms, ±X, ±Y, ±Z 3 times for each direction		
8	Electrostatic Discharge	Contact = ± 8 kV, class B Air = ± 15 kV, class B		IEC61000-4-2
9	Vibration	Frequency range	8 ~ 33.3 Hz	JIS D1601,A10 Condition A
		Stroke	1.3 mm	
		Sweep	2.9 G, 33.3 ~ 400Hz	
		Cycle	15 min.	
		2 hours for each direction of X, Z 4 hours for Y direction		
10	Vibration (with carton)	Random vibration: 0.015 G <sup>2</sup> /Hz from 5 ~ 200 Hz -6 dB/Octave from 200 ~ 500 Hz		IEC 68-34
11	Drop (with carton)	Height: 60 cm 1 corner, 3 edges, 6 surfaces		

Note 1: Ta: Ambient temperature

Note 2: In the standard condition, there is no display function NG issue occurred. All the cosmetic specification is judged before the reliability stress.

Note 3: I<sub>L</sub> = 80mA

## H. Quality Spec

NO.	Inspection Item	Inspection Standards
1	Black spots	$\varphi \leq 0.10$ $0.10 < \varphi \leq 0.3$ $0.3 < \varphi$
2	White spots	$\varphi \leq 0.10$ $0.10 < \varphi \leq 0.3$ $0.3 < \varphi$
3	Bright pixel dot	1 dot R&G&B&W by human eye
4	Dark pixel dot	1 dot by human eye
5	Lines & Scratches	$W \leq 0.03$ and $L \leq 1.0$ $0.03 < W \leq 0.05$ and $L \leq 3.0$ $0.05 < W$ or $L > 3.0$ Visible by human eye
6	Dent/Bubble	$\varphi \leq 0.10$ $0.10 < \varphi \leq 0.3$ $0.30 < \varphi$ Visible by human eye
7	Mura	Visible by human eye at full black/white pattern Visible by 5% ND filter

## I. Packing and Marking

### 1. Packing Form

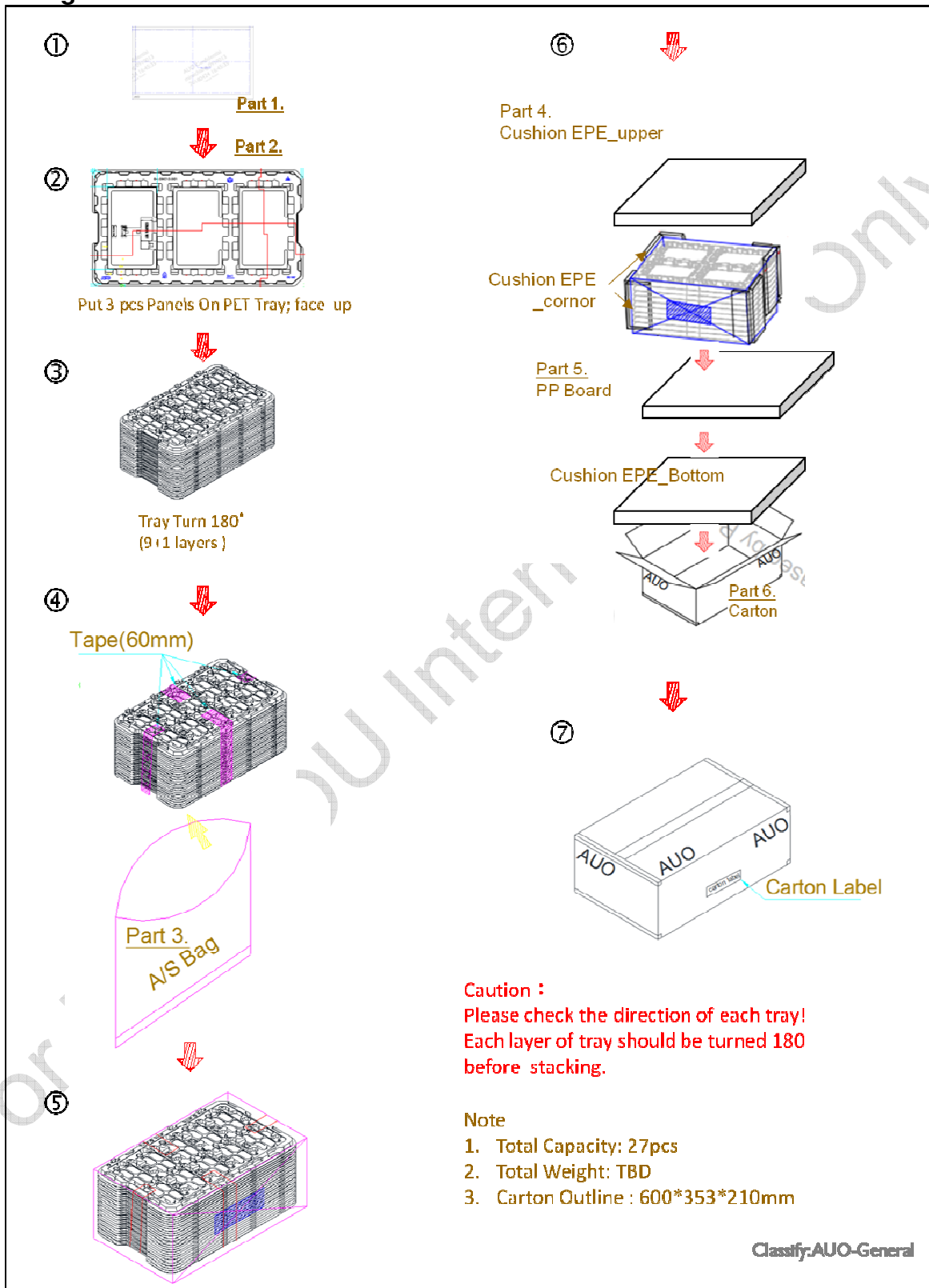

## 2. Module/Panel Label Information

The module/panel (collectively called as the "Product") will be attached with a label of Shipping Number which represents the identification of the Product at a specific location. Refer to the Product outline drawing for detailed location and size of the label. The label is composed of a 22-digit serial number with the following definition:

### ABCDEFGHIJKLMNQRSTUV

- For internal system usage and production serial numbers.
- AUO Module or Panel factory code, represents the final production factory to complete the Product
- Product version code, ranging from 0~9 or A~Z (for Version after 9)
- Week Code, the production week when the product is finished at its production process

Example:

501M06ZL06123456781Z05:

Product Manufacturing Week Code: WK50

Product Version: Version 1

Product Manufacturing Factory: M06

## 3. Carton Label Information

The packing carton will be attached with a carton label where packing Q'ty, AUO Model Name, AUO Part Number, Customer Part Number (Optional) and a series of Carton Number in 13 or 14 digits are printed. The Carton Number is appearing in the following format:

### ABC-DEFG-HIJK-LMN

- DEFG appear after first "-" represents the packing date of the carton
  - Date from 01 to 31
  - Month, ranging from 1~9, A~C. A for Oct, B for Nov and C for Dec.
- A.D. year, ranging from 1~9 and 0. The single digit code represents the last number of the year

Refer to the drawing of packing format for the location and size of the carton label.