

Doc. Number:

- Tentative Specification
- Preliminary Specification
- Approval Specification

**MODEL NO.: N133HCA**  
**SUFFIX: E5A Rev.C1**

**Customer:**

**APPROVED BY**

**SIGNATURE**

**Name / Title**

Note

Please return 1 copy for your confirmation with your signature and comments.

Approved By	Checked By	Prepared By

## CONTENTS

<b>1. GENERAL DESCRIPTION .....</b>	<b>4</b>
1.1 OVERVIEW .....	4
1.2 GENERAL SPECIFICATIONS .....	4
2.1 CONNECTOR TYPE .....	5
<b>3. ABSOLUTE MAXIMUM RATINGS .....</b>	<b>6</b>
3.1 ABSOLUTE RATINGS OF ENVIRONMENT .....	6
3.2 ELECTRICAL ABSOLUTE RATINGS .....	6
3.2.1 TFT LCD MODULE .....	6
<b>4. ELECTRICAL SPECIFICATIONS .....</b>	<b>7</b>
4.1 FUNCTION BLOCK DIAGRAM .....	7
4.2. INTERFACE CONNECTIONS .....	7
4.3 ELECTRICAL CHARACTERISTICS .....	9
4.3.1 LCD ELETRONICS SPECIFICATION .....	9
4.3.2 LED CONVERTER SPECIFICATION .....	11
4.3.3 BACKLIGHT UNIT .....	13
4.4 DISPLAY PORT INPUT SIGNAL TIMING SPECIFICATIONS .....	14
4.4.1 DISPLAY PORT INTERFACE .....	14
4.5 DISPLAY TIMING SPECIFICATIONS .....	15
4.6 POWER ON/OFF SEQUENCE .....	16
<b>5. OPTICAL CHARACTERISTICS .....</b>	<b>19</b>
5.1 TEST CONDITIONS .....	19
5.2 OPTICAL SPECIFICATIONS .....	19
<b>6. RELIABILITY TEST ITEM .....</b>	<b>22</b>
<b>7. PACKING .....</b>	<b>23</b>
7.1 MODULE LABEL .....	23
7.2 CARTON .....	24
7.3 PALLET .....	25
7.4 UN-PACK METHOD .....	26
<b>8. PRECAUTIONS .....</b>	<b>27</b>
8.1 HANDLING PRECAUTIONS .....	27
8.2 STORAGE PRECAUTIONS .....	27
8.3 OPERATION PRECAUTIONS .....	27
Appendix. EDID DATA STRUCTURE .....	28
Appendix. OUTLINE DRAWING .....	31
Appendix. SYSTEM COVER DESIGN GUIDANCE .....	33
Appendix. LCD MODULE HANDLING MANUAL .....	41

**REVISION HISTORY**

Version	Date	Page	Description
0.0	June.5,2019	All	Spec Ver.0.0 was first issued.

## 1. GENERAL DESCRIPTION

### 1.1 OVERVIEW

N133HCA-E5A is a 13.3" (13.3" diagonal) TFT Liquid Crystal Display NB module with LED Backlight unit and 30 pins eDP interface. This module supports 1920 x 1080 FHD mode and can display 262,144 colors.

### 1.2 GENERAL SPECIFICATIONS

Item	Specification	Unit	Note
Screen Size	13.3 diagonal		
Driver Element	a-si TFT active matrix	-	-
Pixel Number	1920 x R.G.B. x 1080	pixel	-
Pixel Pitch	0.1529 (H) x 0.1529 (V)	mm	-
Pixel Arrangement	RGB vertical stripe	-	-
Display Colors	262,144	color	-
Interface	eDP1.2		(2)
Transmissive Mode	Normally Black	-	-
Surface Treatment	Hard coating (3H), Anti-Glare	-	-
Luminance, White	250	Cd/m <sup>2</sup>	
Color Gamma	45%	NTSC	
Power Consumption	Total 3.05W (Max.) @ cell 0.8 (Max.), BL 2.25 W (Max.)		(1)
Special Function Support	G-sync DD (Not support) G-sync nVSR (Not support) Free-sync (Not support)		

Note (1) The specified power consumption (with converter efficiency) is under the conditions at VCCS = 3.3 V,  $f_v = 60$  Hz, LED\_VCCS = Typ,  $f_{PWM} = 200$  Hz, Duty=100% and  $T_a = 25 \pm 2$  °C, whereas mosaic pattern is displayed.

Note (2) Display port interface signals should follow VESA DisplayPort Standard Version1. Revision 1a and VESA Embedded DisplayPort™ Standard Version 1.2 (eDP1.2). There are many optional items described in eDP1.2. If some optional item is requested, please contact us.

## 2. MECHANICAL SPECIFICATIONS

Item	Min.	Typ.	Max.	Unit	Note	
Module Size	Horizontal (H)	299.96	300.26	300.56	mm	(1)(2)
	Vertical (V) (w/o PCB)	177.17	177.47	177.77	mm	
	Thickness (T) (w/o PCB)	-	2.80	3.0	mm	
	Thickness (T) (with PCB)	-	-	5.0	mm	
Active Area	Horizontal	-	293.76	-	mm	
	Vertical	-	165.24	-	mm	
Weight	-	247.6	260	g		

Note (1) Please refer to the attached drawings for more information of front and back outline dimensions.

(2) Dimensions are measured by caliper.

(3) Panel thickness is measured with calipers clamping mylar or tape tightly



### 2.1 CONNECTOR TYPE

Please refer Appendix Outline Drawing for detail design.

Connector Part No.: IPEX-20455-030E-76

User's connector Part No: IPEX-20453-030T-03

## 3. ABSOLUTE MAXIMUM RATINGS

### 3.1 ABSOLUTE RATINGS OF ENVIRONMENT

Item	Symbol	Value		Unit	Note
		Min.	Max.		
Storage Temperature	T <sub>ST</sub>	-20	+60	°C	(1)
Operating Ambient Temperature	T <sub>OP</sub>	0	+50	°C	(1), (2)

Note (1) (a) 90 %RH Max. (T<sub>a</sub> < 40 °C).

(b) Wet-bulb temperature should be 39 °C Max.

(c) No condensation.

Note (2) The temperature of panel surface should be 0 °C min. and 50 °C max.

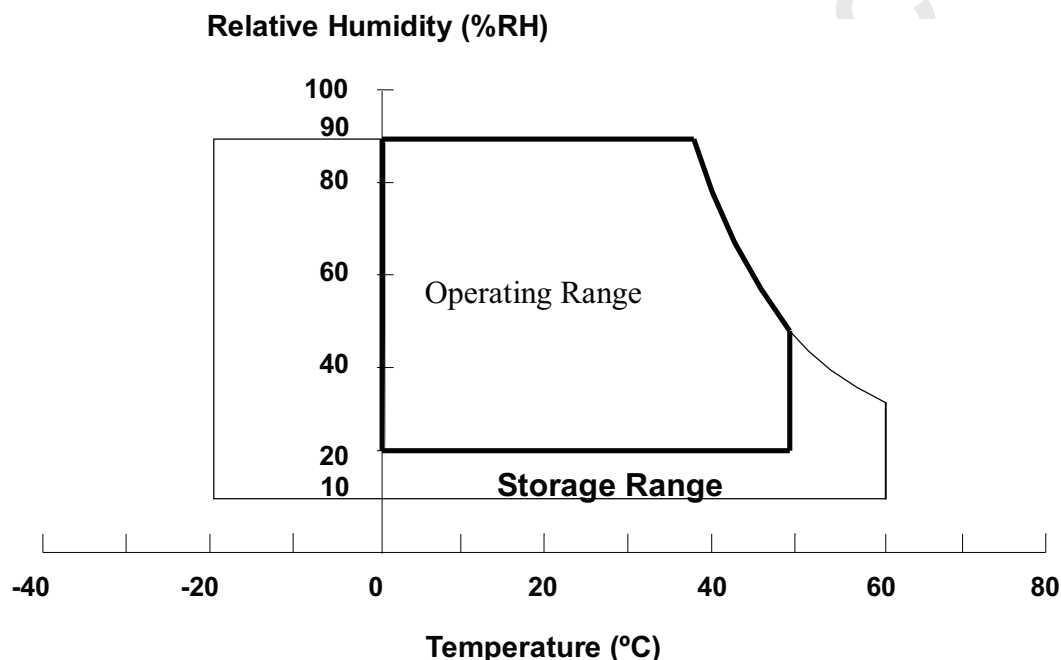

## 3.2 ELECTRICAL ABSOLUTE RATINGS

### 3.2.1 TFT LCD MODULE

Item	Symbol	Value		Unit	Note
		Min.	Max.		
Power Supply Voltage	V <sub>CCS</sub>	-0.3	+4.0	V	(1)
Logic Input Voltage	V <sub>IN</sub>	-0.3	+4.0	V	
Converter Input Voltage	LED_VCCS	-0.3	(26)	V	(1)
Converter Control Signal Voltage	LED_PWM,	-0.3	(5)	V	(1)
Converter Control Signal Voltage	LED_EN	-0.3	(5)	V	(1)

Note (1) Stresses beyond those listed in above "ELECTRICAL ABSOLUTE RATINGS" may cause permanent damage to the device. Normal operation should be restricted to the conditions described in "ELECTRICAL CHARACTERISTICS".

## 4. ELECTRICAL SPECIFICATIONS

### 4.1 FUNCTION BLOCK DIAGRAM

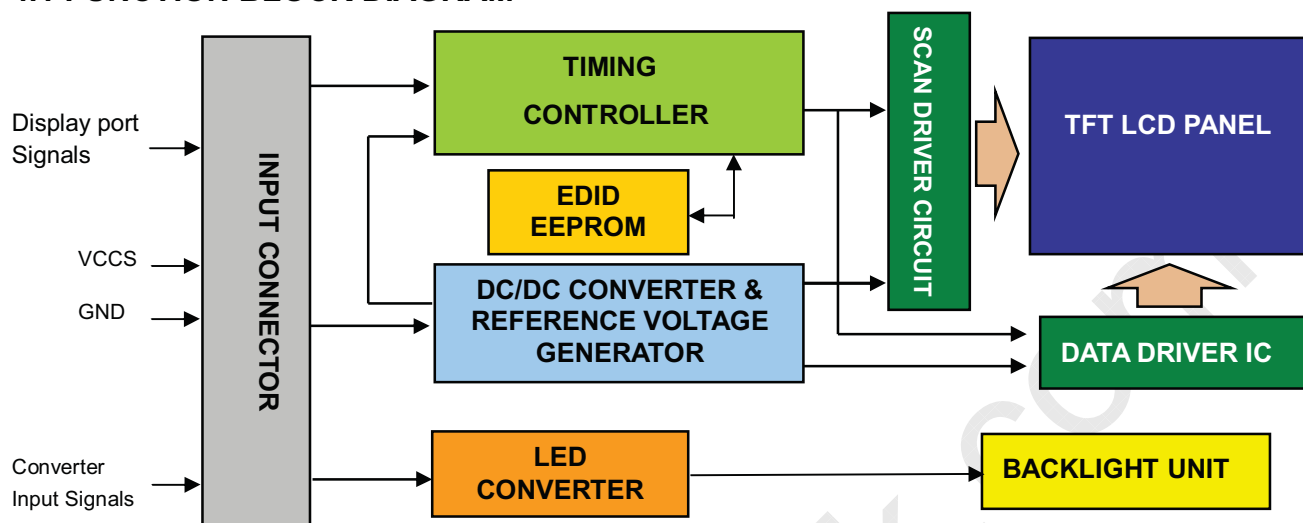

### 4.2. INTERFACE CONNECTIONS

#### PIN ASSIGNMENT

Pin	Symbol	Description	Remark
1	NC	No Connection (Reserved for LCD test)	
2	H_GND	High Speed Ground	
3	Lane1_N	Complement Signal Link Lane 1	
4	Lane1_P	True Signal Link Lane 1	
5	H_GND	High Speed Ground	
6	Lane0_N	Complement Signal Link Lane 0	
7	Lane0_P	True Signal Link Lane 0	
8	H_GND	High Speed Ground	
9	AUX_CH_P	True Signal Auxiliary Channel	
10	AUX_CH_N	Complement Signal Auxiliary Channel	
11	H_GND	High Speed Ground	
12	VCCS	LCD logic and driver power	
13	VCCS	LCD logic and driver power	
14	NC	No Connection (Reserved for LCD test)	
15	GND	LCD logic and driver ground	
16	GND	LCD logic and driver ground	
17	HPD	HPD signal pin	
18	BL_GND	Backlight ground	
19	BL_GND	Backlight ground	
20	BL_GND	Backlight ground	
21	BL_GND	Backlight ground	
22	LED_EN	Backlight on /off	
23	LED_PWM	System PWM signal input for dimming	
24	NC	No Connection (Reserved for LCD test)	
25	NC	No Connection (Reserved for LCD test)	

26	LED_VCCS	Backlight power	
27	LED_VCCS	Backlight power	
28	LED_VCCS	Backlight power	
29	LED_VCCS	Backlight power	
30	NC	No Connection (Reserved for LCD test)	

Note (1) The first pixel is odd as shown in the following figure.

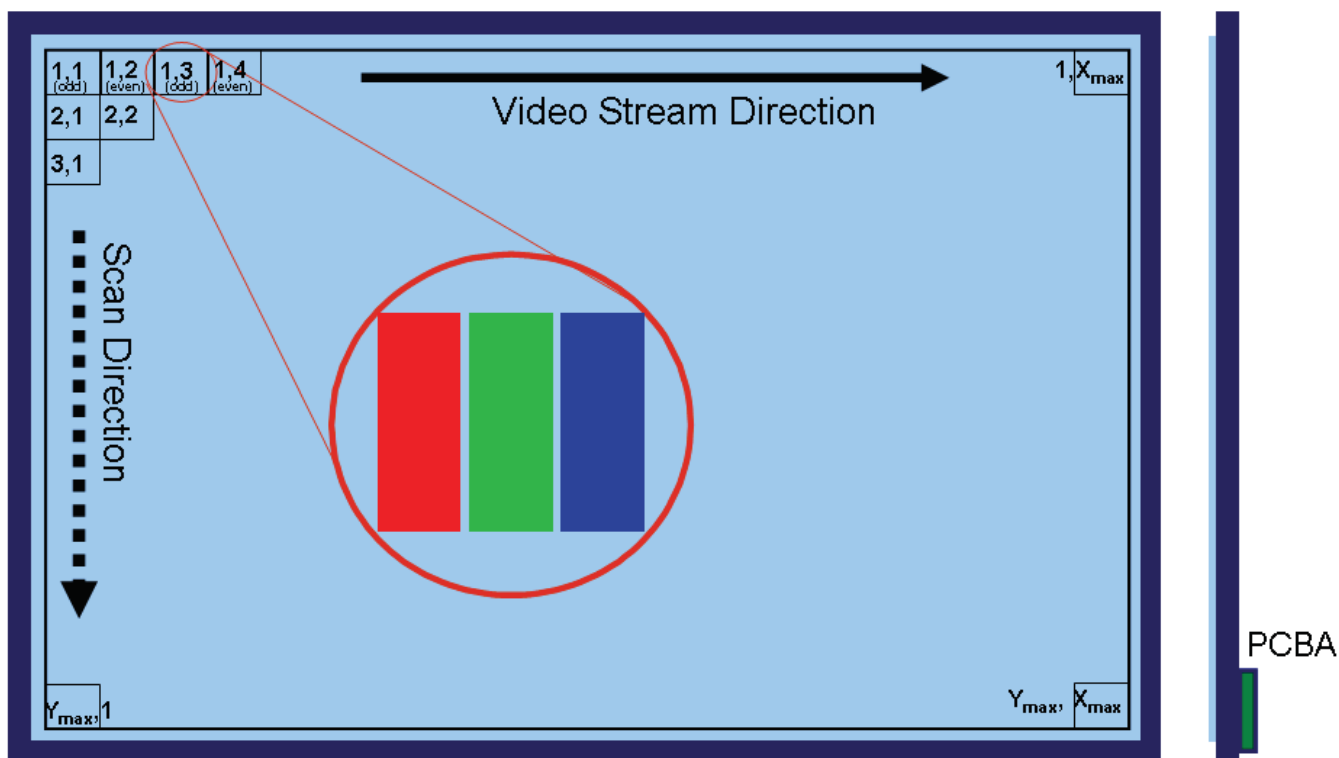



## 4.3 ELECTRICAL CHARACTERISTICS

### 4.3.1 LCD ELETRONICS SPECIFICATION

Parameter	Symbol	Value			Unit	Note	
		Min.	Typ.	Max.			
Power Supply Voltage	VCCS	3.0	3.3	3.6	V	(1)	
HPD	High Level	2.25	-	(2.75)	V	(6)	
	Low Level	0	-	(0.8)	V	(6)	
HPD Impedance	R <sub>HPD</sub>	30K	-	-	ohm	(5)	
Ripple Voltage	V <sub>RP</sub>	-	-	(100)	mV	(1)	
Inrush Current	I <sub>RUSH</sub>	-	-	1.5	A	(1),(2)	
Power Supply Current	Mosaic	I <sub>CC</sub>		(206)	(242)	mA	(3)
	Black			(195)	(226)	mA	(3)
	Solid Pattern		-	(300)	(330)	mA	(3)
Power per EBL WG	P <sub>EBL</sub>	-		(1.34)	W	(4)	

Note (1) The ambient temperature is  $T_a = 25 \pm 2 \text{ }^\circ\text{C}$ .

Note (2) I<sub>RUSH</sub>: the maximum current when VCCS is rising

I<sub>S</sub>: the maximum current of the first 100ms after power-on

Measurement Conditions: Shown as the following figure. Test pattern: black.

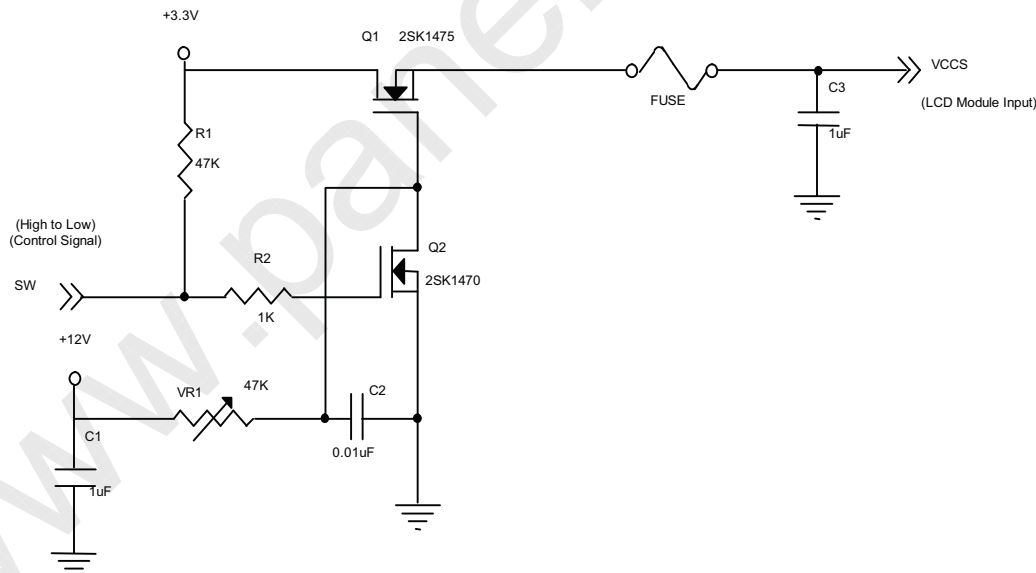

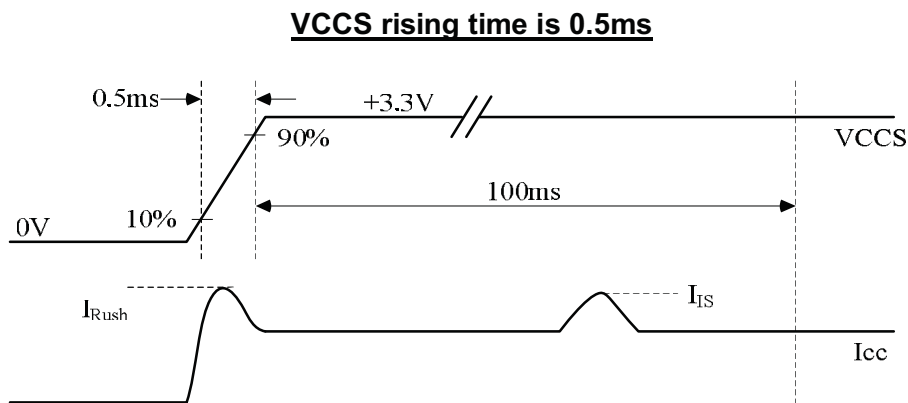

Note (3) The specified power supply current is under the conditions at  $V_{CCS} = 3.3\text{ V}$ ,  $T_a = 25 \pm 2\text{ }^\circ\text{C}$ , DC Current and  $f_v = 60\text{ Hz}$ , whereas a power dissipation check pattern below is displayed.

a. Mosaic Pattern

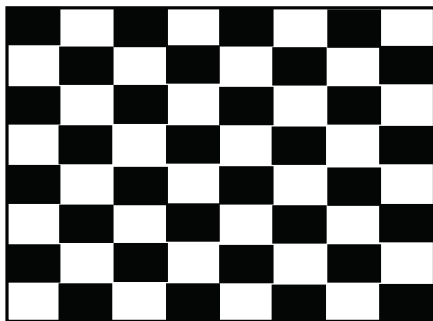

Active Area

b. The solid pattern is the largest one of R/G/B pattern.

Note (4) The specified power are the sum of LCD panel electronics input power and the converter input power. Test conditions are as follows.

(a)  $V_{CCS} = 3.3\text{ V}$ ,  $T_a = 25 \pm 2\text{ }^\circ\text{C}$ ,  $f_v = 60\text{ Hz}$ ,

(b) The pattern used is a black and white 32 x 36 checkerboard, slide #100 from the VESA file "Flat Panel Display Monitor Setup Patterns", FPDMSU.ppt.

(c) Luminance: 60 nits.

Note (5) The specified signals have equivalent impedances pull down to ground in the LCD module respectively. Customers should keep the input signal level requirement with the load of LCD module. Please refer to Note (4) of 4.3.2 LED CONVERTER SPECIFICATION to obtain more information.

Note (6) When a source detects a low-going HPD pulse, it must be regarded as a HPD event. Thus, the source must read the link / sink status field or receiver capability field of the DPCD and take corrective action.

## 4.3.2 LED CONVERTER SPECIFICATION

Parameter		Symbol	Value			Unit	Note
			Min.	Typ.	Max.		
Converter Input power supply voltage		LED_Vccs	(5)	(12)	(21)	V	
Converter Inrush Current		I <sub>LED_RUSH</sub>	-	-	1.5	A	(1)
EN Control Level	Backlight On		(2.2)	-	(3.6)	V	(4)
	Backlight Off		0	-	(0.6)	V	(4)
LED_EN Impedance		R <sub>LED_EN</sub>	30K	-	-	ohm	(4)
PWM Control Level	PWM High Level		(2.2)	-	3.6	V	(4)
	PWM Low Level		0	-	(0.6)	V	(4)
PWM Impedance		R <sub>PWM</sub>	30K	-	-	ohm	(4)
PWM Control Duty Ratio			5	-	100	%	(5)
PWM Control Permissible Ripple Voltage		V <sub>PWM_pp</sub>	-	-	100	mV	
PWM Control Frequency		f <sub>PWM</sub>	190	-	2K	Hz	(2)
LED Power Current	LED_VCCS =Typ.	I <sub>LED</sub>	(144)	(176)	(187.5)	mA	(3)

Note (1) I<sub>LED\_RUSH</sub>: the maximum current when LED\_VCCS is rising,

I<sub>LED\_IS</sub>: the maximum current of the first 100ms after power-on,

Measurement Conditions: Shown as the following figure. LED\_VCCS = Typ, Ta = 25 ± 2 °C, f<sub>PWM</sub> = 200 Hz, Duty=100%.

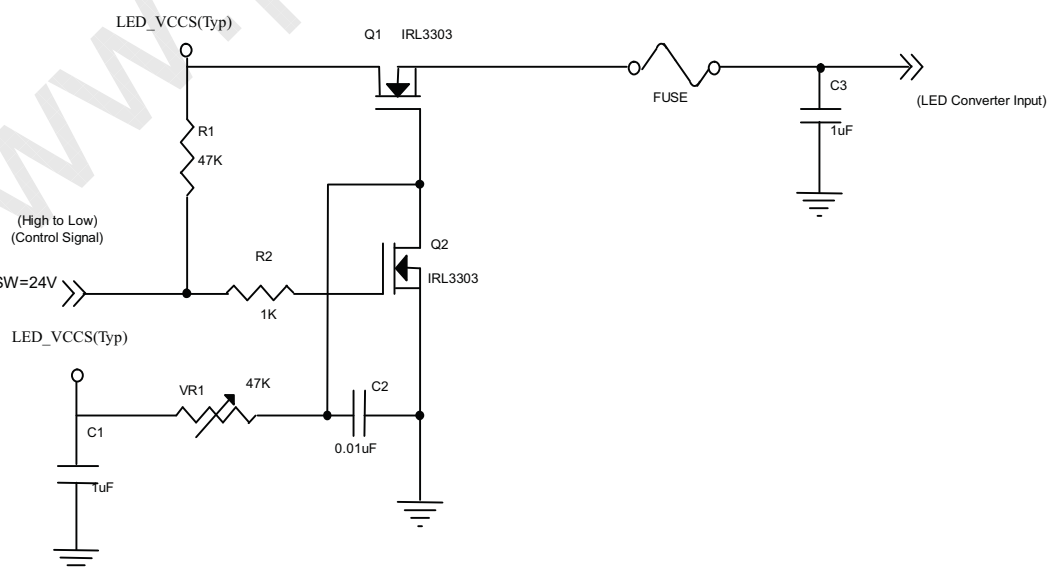

## VLED rising time is 0.5ms

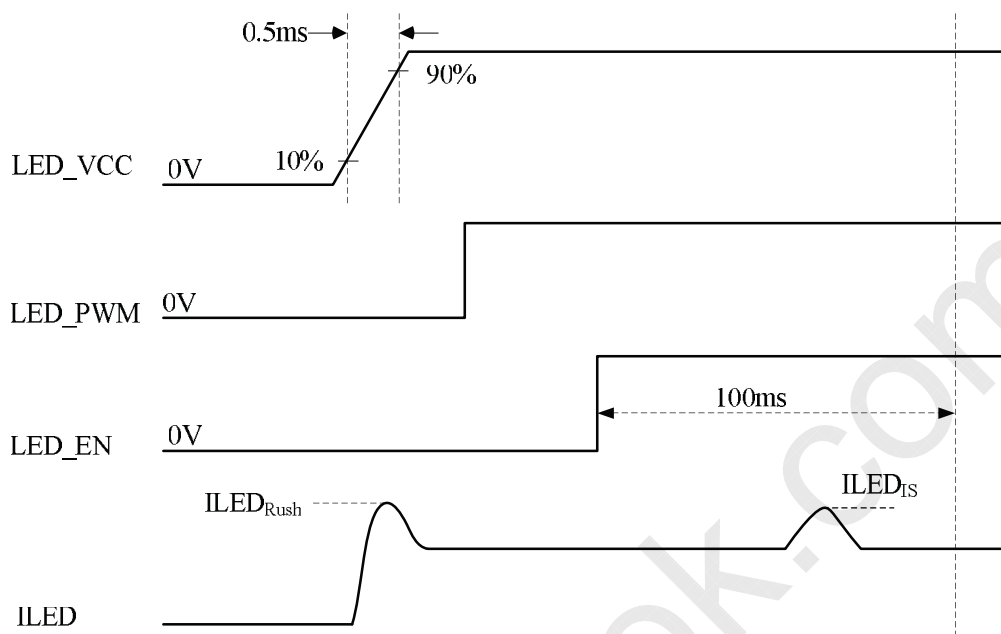

Note (2) If PWM control frequency is applied in the range less than 1KHz, the “waterfall” phenomenon on the screen may be found. To avoid the issue, it’s a suggestion that PWM control frequency should follow the criterion as below.

PWM control frequency  $f_{PWM}$  should be in the range

$$(N + 0.33) * f \leq f_{PWM} \leq (N + 0.66) * f$$

$N$  : Integer ( $N \geq 3$ )

$f$  : Frame rate

Note (3) The specified LED power supply current is under the conditions at “LED\_VCCS = Typ.”,  $T_a = 25 \pm 2$  °C,  $f_{PWM} = 200$  Hz, Duty=100%.

Note (4) The specified signals have equivalent impedances pull down to ground in the LCD module respectively. Customers should keep the input signal level requirement with the load of LCD module. For example, the figure below describes the equivalent pull down impedance of LED\_EN (If it exists). The rest pull down impedances of other signals (eg. HPD, PWM ...) are in the same concept.

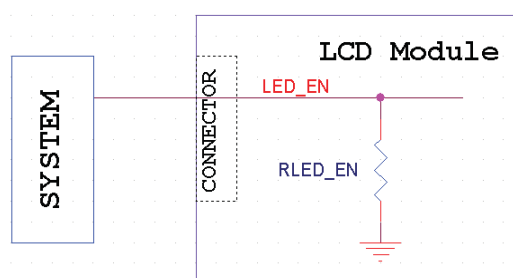

Note (5) If the cycle-to-cycle difference of PWM duty exceeds 0.1%, especially when the PWM duty is low, slight brightness change might be observed.

## 4.3.3 BACKLIGHT UNIT

 $T_a = 25 \pm 2 \text{ }^\circ\text{C}$ 

Parameter	Symbol	Value			Unit	Note
		Min.	Typ.	Max.		
LED Light Bar Power Supply Voltage	$V_L$	23.4	25.2	27	V	(1)(2)(Duty100%)
LED Light Bar Power Supply Current	$I_L$		62.1		mA	
Power Consumption	$P_L$		1.815	1.944	W	(3)
LED Life Time	$L_{BL}$	15000	-	-	Hrs	(4)

Note (1) LED current is measured by utilizing a high frequency current meter as shown below :

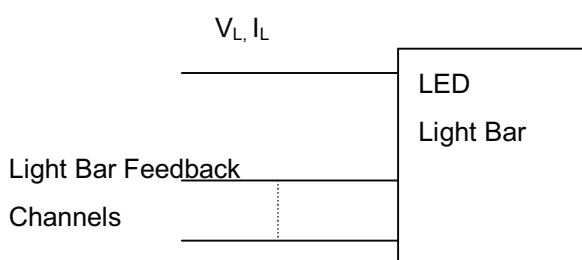

Note (2) For better LED light bar driving quality, it is recommended to utilize the adaptive boost converter with current balancing function to drive LED light-bar.

Note (3)  $P_L = I_L \times V_L$  (Without LED converter transfer efficiency)

Note (4) The lifetime of LED is defined as the time when it continues to operate under the conditions at  $T_a = 25 \pm 2 \text{ }^\circ\text{C}$  and  $I_L = 24 \text{ mA}$  (Per EA) until the brightness becomes  $\leq 50\%$  of its original value.

## 4.4 DISPLAY PORT INPUT SIGNAL TIMING SPECIFICATIONS

### 4.4.1 DISPLAY PORT INTERFACE

Parameter	Symbol	Min.	Typ.	Max.	Unit	Notes
Differential Signal Common Mode Voltage(MainLink and AUX)	VCM	0		2	V	(1)(4)
AUX AC Coupling Capacitor	C_Aux_Source	75		200	nF	(2)
Main Link AC Coupling Capacitor	C_ML_Source	75		200	nF	(3)

Note (1) Display port interface related AC coupled signals should follow VESA DisplayPort Standard Version 1. Revision 1a and VESA Embedded DisplayPort™ Standard Version 1.2. There are many optional items described in eDP 1.2. If some optional item is requested, please contact us.

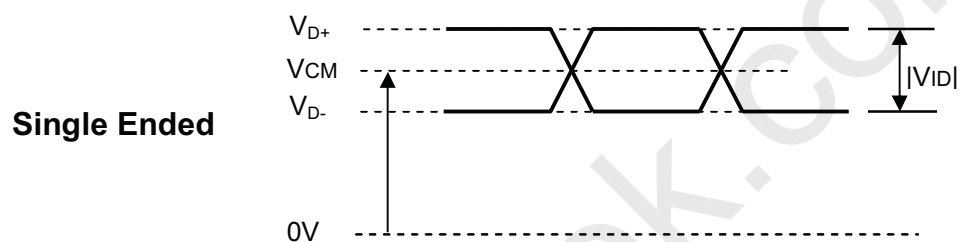

(2) Recommended eDP AUX Channel topology is as below and the AUX AC Coupling Capacitor (C\_Aux\_Source) should be placed on the source device.

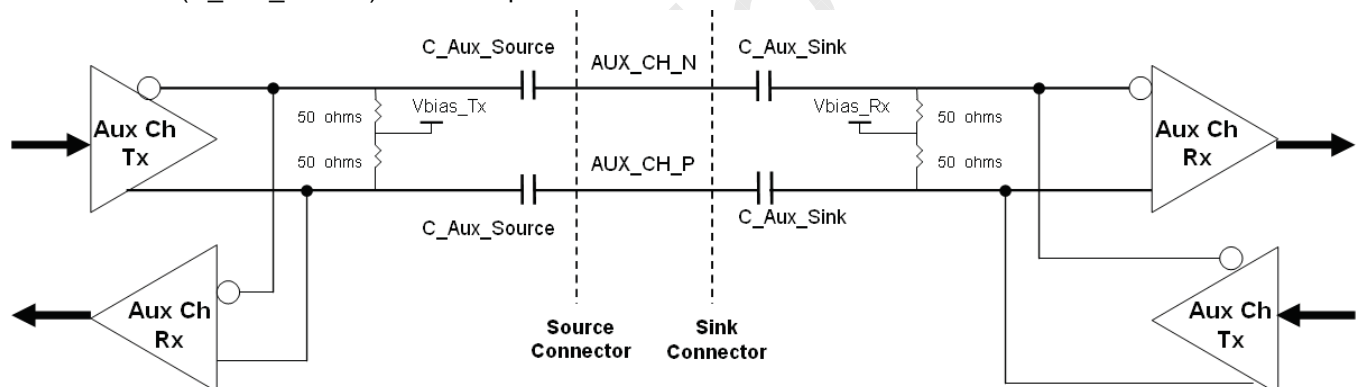

(3) Recommended Main Link Channel topology is as below and the Main Link AC Coupling Capacitor (C\_ML\_Source) should be placed on the source device.

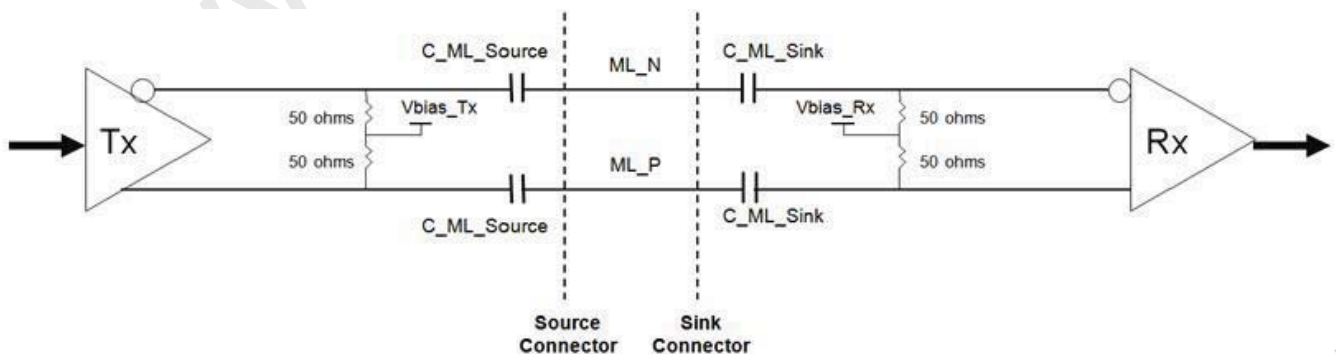

(4) The source device should pass the test criteria described in Display Port Compliance Test Specification (CTS) 1.1

## 4.5 DISPLAY TIMING SPECIFICATIONS

The input signal timing specifications are shown as the following table and timing diagram.

### Refresh Rate 60Hz

Signal	Item	Symbol	Min.	Typ.	Max.	Unit	Note
DCLK	Frequency	1/Tc	152.08	152.84	153.6	MHz	-
DE	Vertical Total Time	TV	1128	1132	1136	TH	-
	Vertical Active Display Period	TVD	1080	1080	1080	TH	-
	Vertical Active Blanking Period	TVB	TV-TVD	52	TV-TVD	TH	-
	Horizontal Total Time	TH	2230	2250	2270	Tc	-
	Horizontal Active Display Period	THD	1920	1920	1920	Tc	-
	Horizontal Active Blanking Period	THB	TH-THD	330	TH-THD	Tc	-

### Refresh rate 40Hz (Power Saving Mode)

Signal	Item	Symbol	Min.	Typ.	Max.	Unit	Note
DCLK	Frequency	1/Tc	101.38	101.88	102.4	MHz	(1)
DE	Vertical Total Time	TV	1128	1132	1136	TH	(1)
	Vertical Active Display Period	TVD	1080	1080	1080	TH	(1)
	Vertical Active Blanking Period	TVB	TV-TVD	52	TV-TVD	TH	(1)
	Horizontal Total Time	TH	2230	2250	2270	Tc	(1)
	Horizontal Active Display Period	THD	1920	1920	1920	Tc	(1)
	Horizontal Active Blanking Period	THB	TH-THD	330	TH-THD	Tc	(1)

Note (1) The panel can operate at 60Hz normal mode and power saving mode, respectively. All reliability tests are based on specific timing of 60Hz refresh rate. We can only assure the panel's electrical function at power saving mode.

### INPUT SIGNAL TIMING DIAGRAM

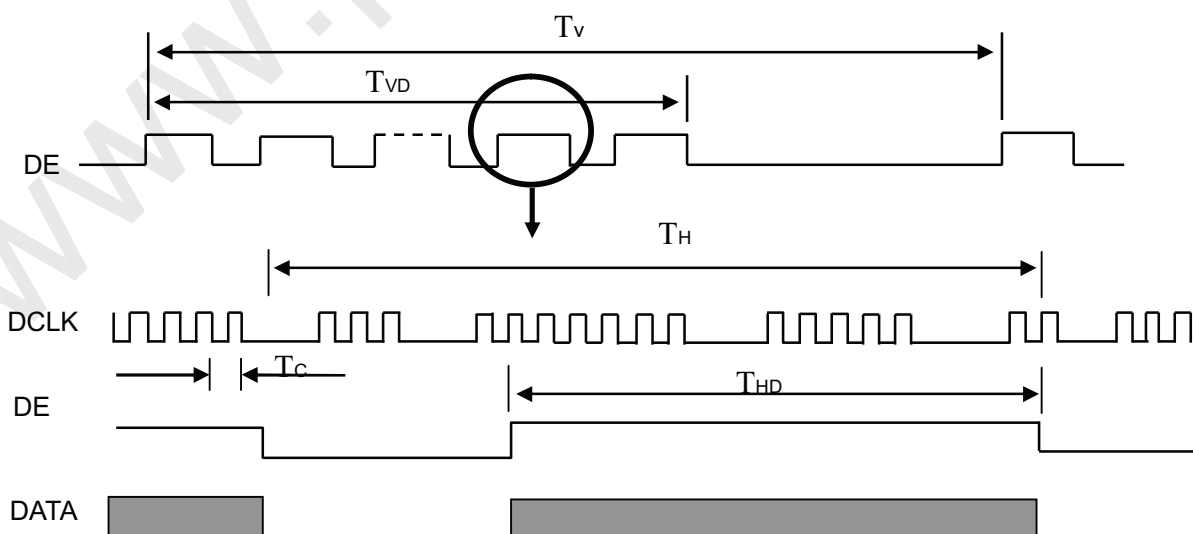

## 4.6 POWER ON/OFF SEQUENCE

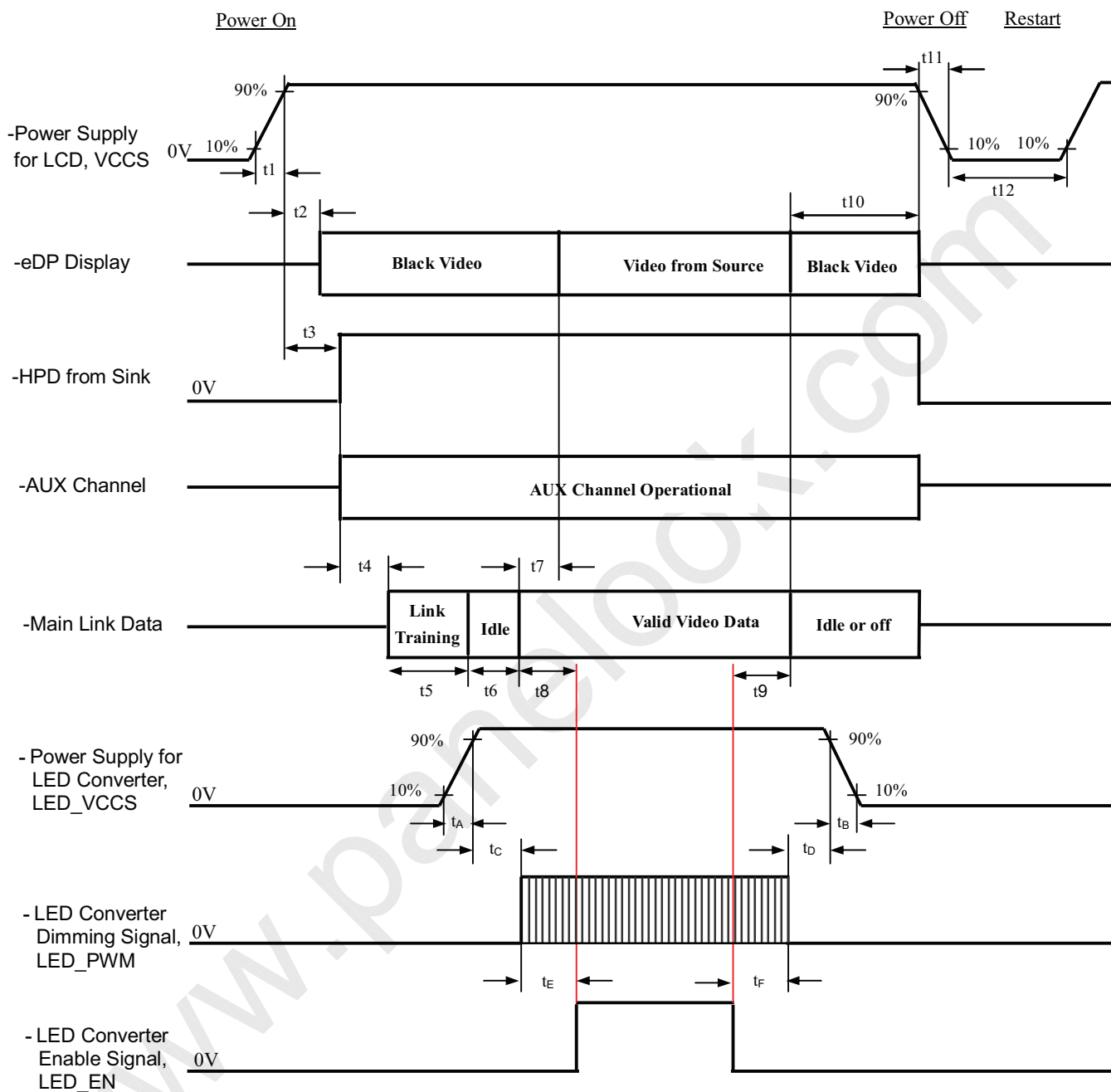



# PRODUCT SPECIFICATION

## Timing Specifications

Parameter	Description	Reqd. By	Value		Unit	Notes
			Min	Max		
t1	Power rail rise time, 10% to 90%	Source	0.5	10	ms	-
t2	Delay from LCD,VCCS to black video generation	Sink	0	200	ms	Automatic Black Video generation prevents display noise until valid video data is received from the Source (see Notes:2 and 3 below)
t3	Delay from LCD,VCCS to HPD high	Sink	0	200	ms	Sink AUX Channel must be operational upon HPD high (see Note:4 below )
t4	Delay from HPD high to link training initialization	Source	0	-	ms	Allows for Source to read Link capability and initialize
t5	Link training duration	Source	0	-	ms	Dependant on Source link training protocol
t6	Link idle	Source	0	-	ms	Min Accounts for required BS-Idle pattern. Max allows for Source frame synchronization
t7	Delay from valid video data from Source to video on display	Sink	0	50	ms	Max value allows for Sink to validate video data and timing. At the end of T7, Sink will indicate the detection of valid video data by setting the SINK_STATUS bit to logic 1 (DPCD 00205h, bit 0), and Sink will no longer generate automatic Black Video
t8	Delay from valid video data from Source to backlight on	Source	80	-	ms	Source must assure display video is stable *: Recommended by INX. To avoid garbage image.
t9	Delay from backlight off to end of valid video data	Source	50	-	ms	Source must assure backlight is no longer illuminated. At the end of T9, Sink will indicate the detection of no valid video data by setting the SINK_STATUS bit to logic 0 (DPCD 00205h, bit 0), and Sink will automatically display Black Video. (See Notes: 2 and 3 below) *: Recommended by INX. To avoid garbage image.
t10	Delay from end of valid video data from Source to power off	Source	0	500	ms	Black video will be displayed after receiving idle or off signals from Source
t11	VCCS power rail fall time, 90% to 10%	Source	0.5	10	ms	-

t <sub>12</sub>	VCCS Power off time	Source	500	-	ms	-
t <sub>A</sub>	LED power rail rise time, 10% to 90%	Source	0.5	10	ms	-
t <sub>B</sub>	LED power rail fall time, 90% to 10%	Source	0	10	ms	-
t <sub>C</sub>	Delay from LED power rising to LED dimming signal	Source	1	-	ms	-
t <sub>D</sub>	Delay from LED dimming signal to LED power falling	Source	1	-	ms	-
t <sub>E</sub>	Delay from LED dimming signal to LED enable signal	Source	0	-	ms	-
t <sub>F</sub>	Delay from LED enable signal to LED dimming signal	Source	0	-	ms	-

Note (1) Please don't plug or unplug the interface cable when system is turned on.

Note (2) The Sink must include the ability to automatically generate Black Video autonomously. The Sink must automatically enable Black Video under the following conditions:

- Upon LCDVCC power-on (within T<sub>2</sub> max)
- When the "NoVideoStream\_Flag" (VB-ID Bit 3) is received from the Source (at the end of T<sub>9</sub>)

Note (3) The Sink may implement the ability to disable the automatic Black Video function, as described in Note (2), above, for system development and debugging purposes.

Note (4) The Sink must support AUX Channel polling by the Source immediately following LCDVCC power-on without causing damage to the Sink device (the Source can re-try if the Sink is not ready). The Sink must be able to response to an AUX Channel transaction with the time specified within T<sub>3</sub> max.

## 5. OPTICAL CHARACTERISTICS

### 5.1 TEST CONDITIONS

Item	Symbol	Value	Unit
Ambient Temperature	Ta	25±2	°C
Ambient Humidity	Ha	50±10	%RH
Supply Voltage	V <sub>CC</sub>	3.3	V
Input Signal	According to typical value in "3. ELECTRICAL CHARACTERISTICS"		
LED Light Bar Input Current	I <sub>L</sub>	62.1	mA

The measurement methods of optical characteristics are shown in Section 5.2. The following items should be measured under the test conditions described in Section 5.1 and stable environment shown in Note(5).

### 5.2 OPTICAL SPECIFICATIONS

Item		Symbol	Condition	Min.	Typ.	Max.	Unit	Note
Contrast Ratio		CR	$\theta_x=0^\circ, \theta_y=0^\circ$ Viewing Normal Angle	800	1000	-	-	(2), (5), (7)
Response Time		T <sub>R</sub>		-	11	14	ms	(3), (7)
		T <sub>F</sub>		-	9	11	ms	
Average Luminance of White		L <sub>AVE</sub>		212	250	-	cd/m <sup>2</sup>	(4), (6), (7)
Color Chromaticity	Red	R <sub>x</sub>	$\theta_x=0^\circ, \theta_y=0^\circ$ Viewing Normal Angle	Typ - 0.03	0.590	Typ + 0.03	-	(1), (7)
		R <sub>y</sub>			0.350		-	
	Green	G <sub>x</sub>			0.330		-	
		G <sub>y</sub>			0.555		-	
	Blue	B <sub>x</sub>			0.153		-	
		B <sub>y</sub>			0.119		-	
	White	W <sub>x</sub>			0.313		-	
		W <sub>y</sub>			0.329		-	
Viewing Angle	Horizontal	$\theta_{x+}$	CR≥10	80	89	-	Deg.	(1), (5), (7)
		$\theta_{x-}$		80	89	-		
	Vertical	$\theta_{y+}$		80	89	-		
		$\theta_{y-}$		80	89	-		
White Variation		$\delta W_{5p}$	$\theta_x=0^\circ, \theta_y=0^\circ$	-	1.11	1.25	-	(5), (6), (7)
		$\delta W_{13p}$	$\theta_x=0^\circ, \theta_y=0^\circ$	-	1.33	1.54	-	

Note (1) Definition of Viewing Angle ( $\theta_x$ ,  $\theta_y$ ):

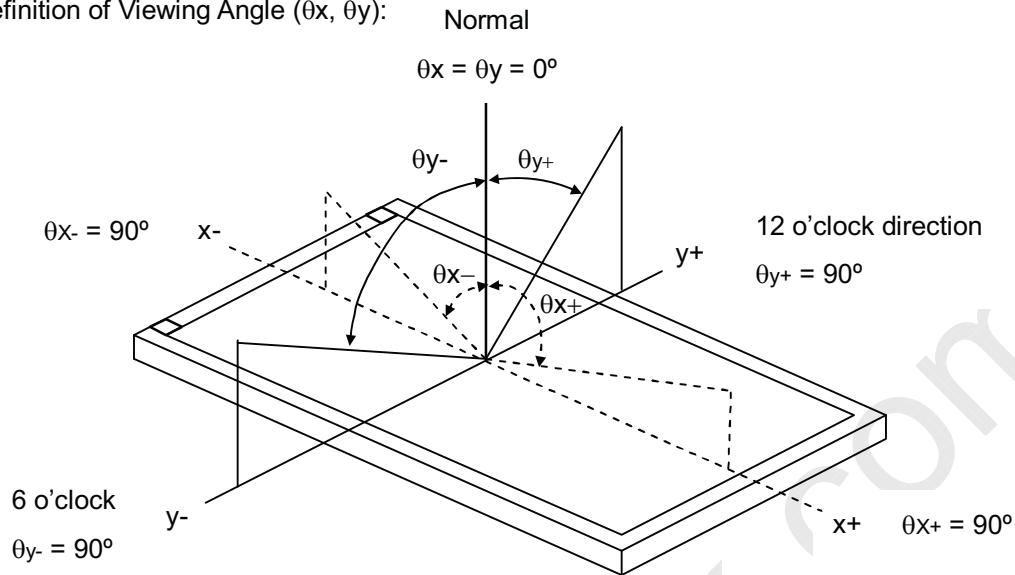

Note (2) Definition of Contrast Ratio (CR):

The contrast ratio can be calculated by the following expression.

$$\text{Contrast Ratio (CR)} = L_{63} / L_0$$

L63: Luminance of gray level 63

L 0: Luminance of gray level 0

$$\text{CR} = \text{CR} (1)$$

CR (X) is corresponding to the Contrast Ratio of the point X at Figure in Note (6).

Note (3) Definition of Response Time ( $T_R$ ,  $T_F$ ):

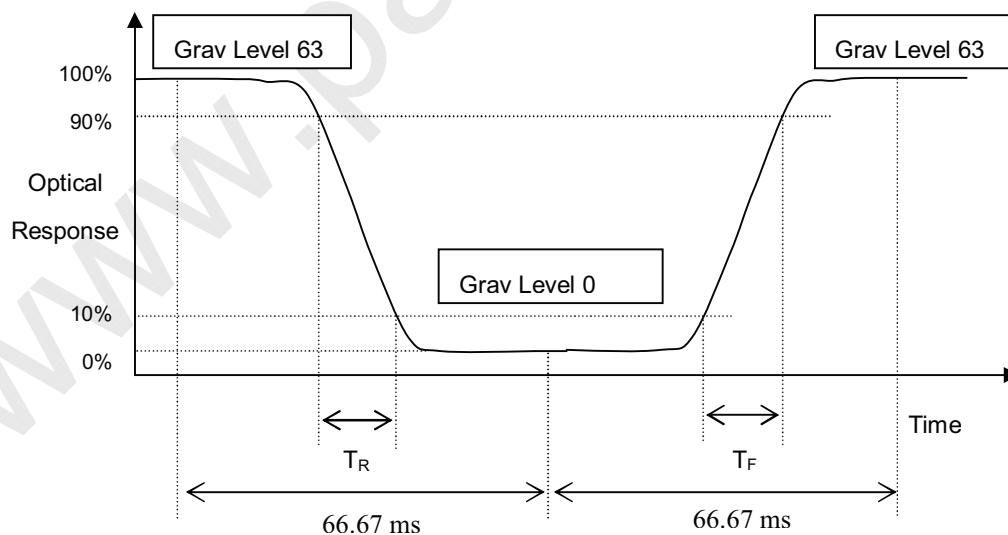

Note (4) Definition of Average Luminance of White ( $L_{AVE}$ ):

Measure the luminance of gray level 63 at 5 points

$$L_{AVE} = [L (1) + L (2) + L (3) + L (4) + L (5)] / 5$$

L (x) is corresponding to the luminance of the point X at Figure in Note (6)

## Note (5) Measurement Setup:

The LCD module should be stabilized at given temperature for 20 minutes to avoid abrupt temperature change during measuring. In order to stabilize the luminance, the measurement should be executed after lighting Backlight for 20 minutes in a windless room.

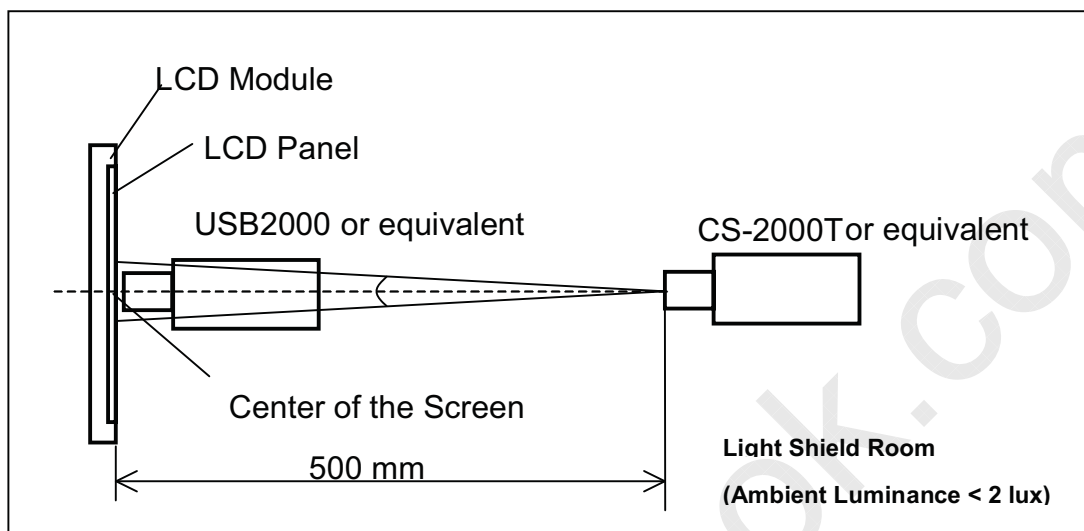

## Note (6) Definition of White Variation ( $\delta W$ ):

Measure the luminance of gray level 63 at 5 points

$$\delta W_{5p} = \text{Maximum [L(1) ~ L(5)]} / \text{Minimum [L(1) ~ L(5)]}$$

$$\delta W_{13p} = \text{Maximum [L(1) ~ L(13)]} / \text{Minimum [L(1) ~ L(13)]}$$

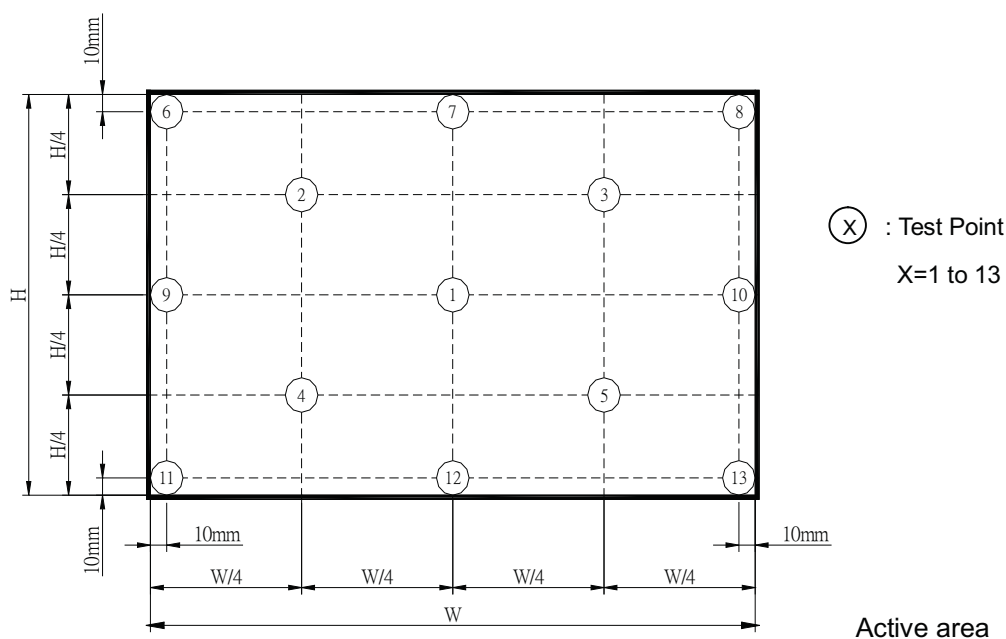

Note (7) The listed optical specifications refer to the initial value of manufacture, but the condition of the specifications after long-term operation will not be warranted.

## 6. RELIABILITY TEST ITEM

Test Item	Test Condition	Note
High Temperature Storage Test	60°C, 240 hours	(1) (2)
Low Temperature Storage Test	-20°C, 240 hours	
Thermal Shock Storage Test	-20°C, 0.5hour←→60°C, 0.5hour; 100cycles, 1hour/cycle	
High Temperature Operation Test	50°C, 240 hours	
Low Temperature Operation Test	0°C, 240 hours	
High Temperature & High Humidity Operation Test	50°C, RH 80%, 240hours	
ESD Test (Operation)	150pF, 330Ω, 1sec/cycle Condition 1 : Contact Discharge, ±8KV Condition 2 : Air Discharge, ±15KV	(1)
Shock (Non-Operating)	220G, 2ms, half sine wave, 1 time for each direction of ±X,±Y,±Z	(1)(3)
Vibration (Non-Operating)	1.5G / 10-500 Hz, Sine wave, 30 min/cycle, 1cycle for each X, Y, Z	(1)(3)

Note (1) Criteria : Normal display image with no obvious non-uniformity and no line defect.

Note (2) Evaluation should be tested after storage at room temperature for more than two hour

Note (3) At testing Vibration and Shock, the fixture in holding the module has to be hard and rigid enough so that the module would not be twisted or bent by the fixture.

## 7. PACKING

### 7.1 MODULE LABEL

The barcode nameplate is pasted on each module as illustration, and its definitions are as following explanation.

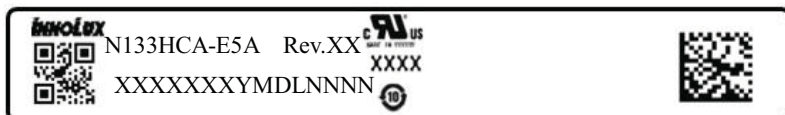

- (a) Model Name: N133HCA-E5A
- (b) Revision: Rev. XX, for example: C1, C2 ...etc.
- (c) Serial ID: XXXXXXYMDLNNNN

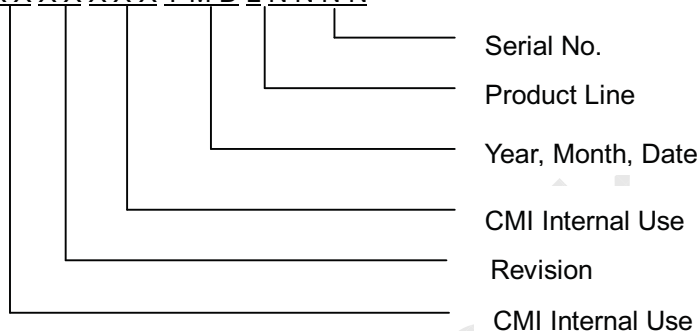

- (d) Production Location: MADE IN XXXX.
- (e) UL Logo: XXXX or XXXXX is UL factory ID.
- (f) X: A means A Bom, B means B Bom etc..

Serial ID includes the information as below:

- (a) Manufactured Date: Year: 0~9, for 2010~2019  
 Month: 1~9, A~C, for Jan. ~ Dec.  
 Day: 1~9, A~Y, for 1<sup>st</sup> to 31<sup>st</sup>, exclude I, O and U
- (b) Revision Code: cover all the change
- (c) Serial No.: Manufacturing sequence of product
- (d) Product Line: 1 -> Line1, 2 -> Line 2, ...etc.

## 7.2 CARTON

(1) Box Dimensions : 540(L)\*450(W)\*320(H)

(2) 40 Modules/Carton

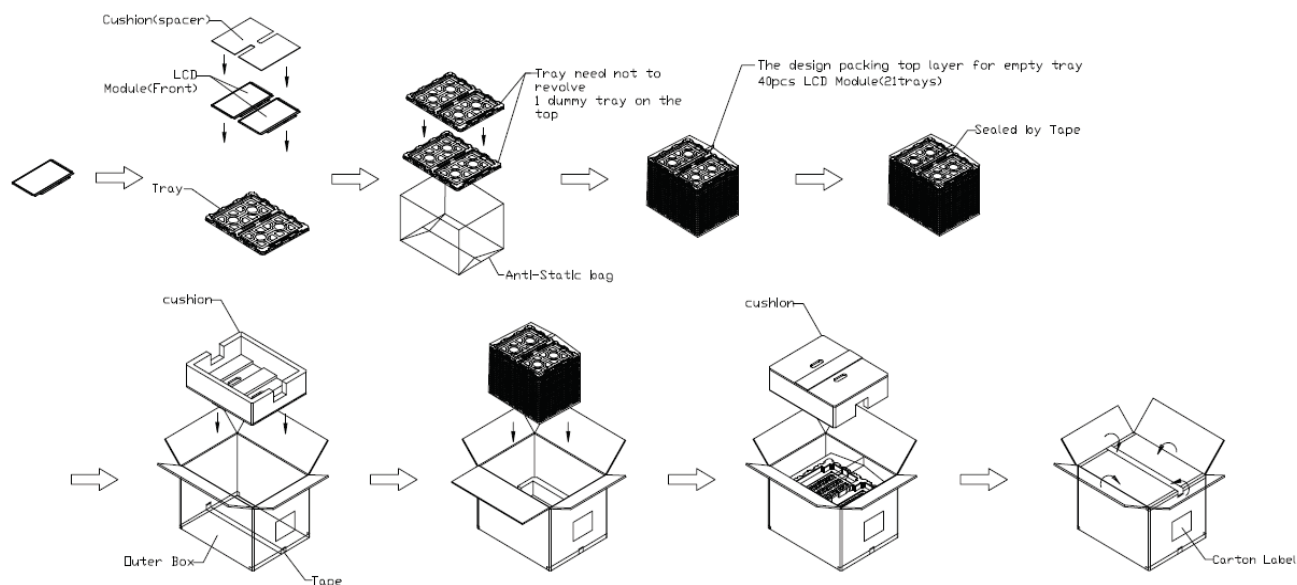

Figure. 7-2 Packing method



## 7.3 PALLET

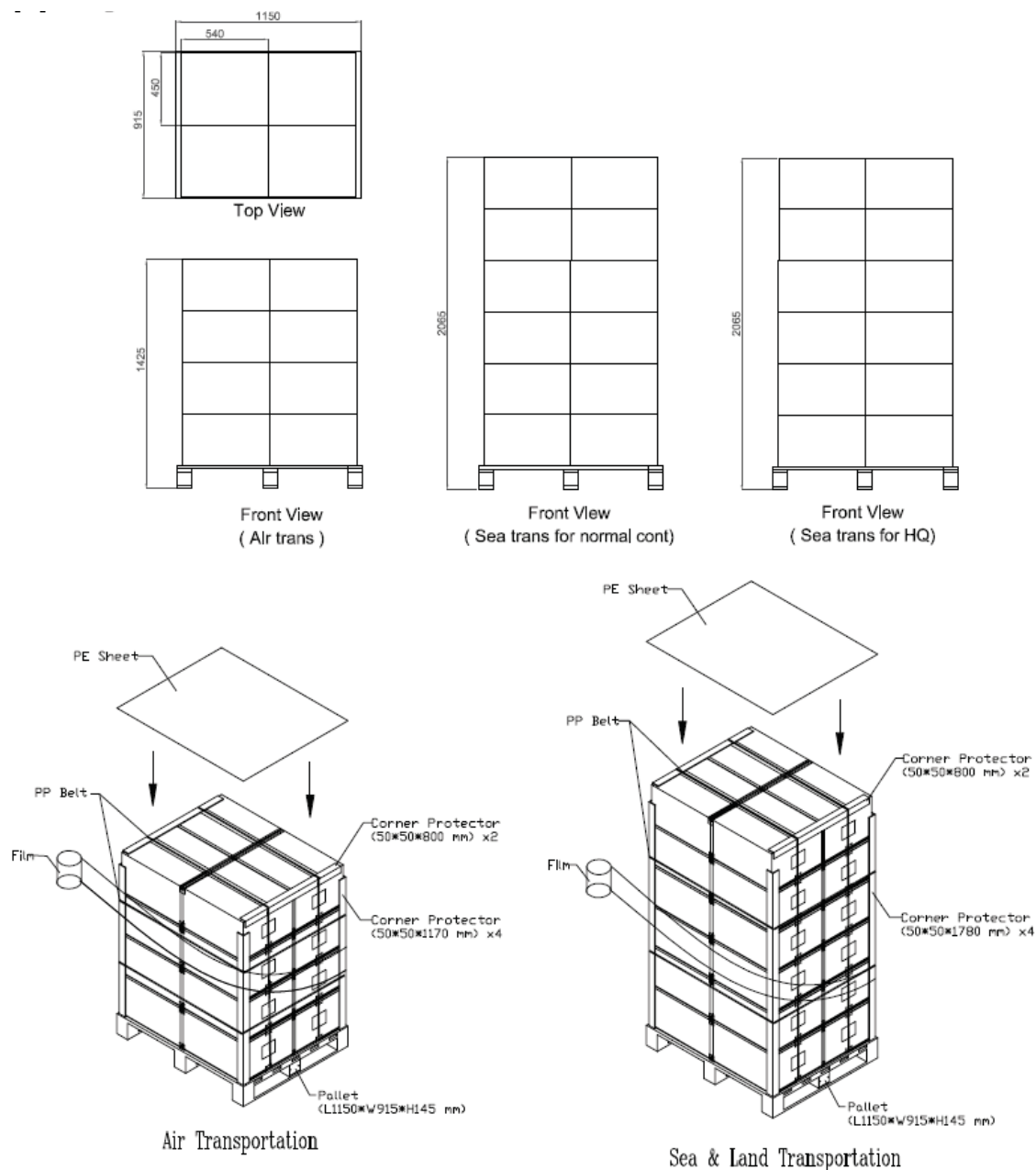

Figure. 7-3 Packing method

**7.4 UN-PACK METHOD**

Figure.7-4 Un-Pack method

## 8. PRECAUTIONS

### 8.1 HANDLING PRECAUTIONS

- (1) The module should be assembled into the system firmly by using every mounting hole. Be careful not to twist or bend the module.
- (2) While assembling or installing modules, it can only be in the clean area. The dust and oil may cause electrical short or damage the polarizer.
- (3) Use fingerstalls or soft gloves in order to keep display clean during the incoming inspection and assembly process.
- (4) Do not press or scratch the surface harder than a HB pencil lead on the panel because the polarizer is very soft and easily scratched.
- (5) If the surface of the polarizer is dirty, please clean it by some absorbent cotton or soft cloth. Do not use Ketone type materials (ex. Acetone), Ethyl alcohol, Toluene, Ethyl acid or Methyl chloride. It might permanently damage the polarizer due to chemical reaction.
- (6) Wipe off water droplets or oil immediately. Staining and discoloration may occur if they left on panel for a long time.
- (7) If the liquid crystal material leaks from the panel, it should be kept away from the eyes or mouth. In case of contacting with hands, legs or clothes, it must be washed away thoroughly with soap.
- (8) Protect the module from static electricity, it may cause damage to the C-MOS Gate Array IC.
- (9) Do not disassemble the module.
- (10) Do not pull or fold the LED wire.
- (11) Pins of I/F connector should not be touched directly with bare hands.

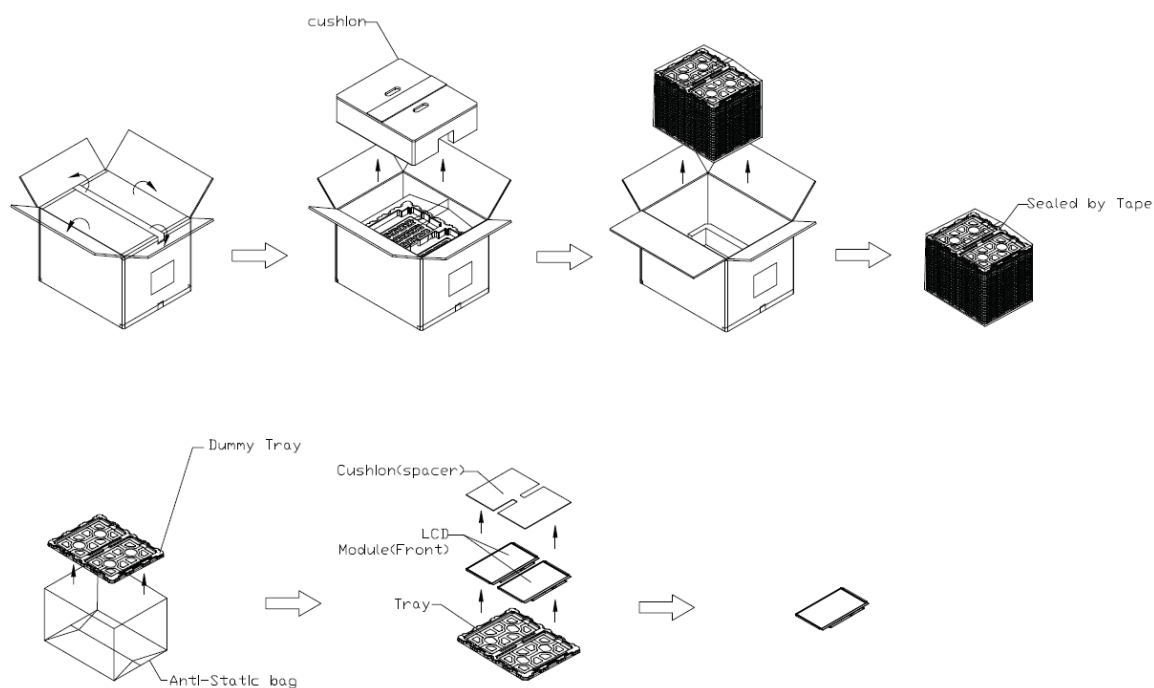
### 8.2 STORAGE PRECAUTIONS

- (1) High temperature or humidity may reduce the performance of module. Please store LCD module within the specified storage conditions.
- (2) It is dangerous that moisture come into or contacted the LCD module, because the moisture may damage LCD module when it is operating.
- (3) It may reduce the display quality if the ambient temperature is lower than 10 °C. For example, the response time will become slowly, and the starting voltage of LED will be higher than the room temperature.

### 8.3 OPERATION PRECAUTIONS

- (1) Do not pull the I/F connector in or out while the module is operating.
- (2) Always follow the correct power on/off sequence when LCD module is connecting and operating. This can prevent the CMIS LSI chips from damage during latch-up.
- (3) The startup voltage of Backlight is approximately 1000 Volts. It may cause electrical shock while assembling with converter. Do not disassemble the module or insert anything into the Backlight unit.

## Appendix. EDID DATA STRUCTURE(待 EE 後續更新)

The EDID (Extended Display Identification Data) data formats are to support displays as defined in the VESA Plug & Display and FPD1 standards.

Byte # (decimal)	Byte # (hex)	Field Name and Comments	Value (hex)	Value (binary)
0	00	Header	00	00000000
1	01	Header	FF	11111111
2	02	Header	FF	11111111
3	03	Header	FF	11111111
4	04	Header	FF	11111111
5	05	Header	FF	11111111
6	06	Header	FF	11111111
7	07	Header	00	00000000
8	08	EISA ID manufacturer name ("CMN")	0D	00001101
9	09	EISA ID manufacturer name	AE	10101110
10	0A	ID product code (LSB)	9E	10011110
11	0B	ID product code (MSB)	13	00010011
12	0C	ID S/N (fixed "0")	00	00000000
13	0D	ID S/N (fixed "0")	00	00000000
14	0E	ID S/N (fixed "0")	00	00000000
15	0F	ID S/N (fixed "0")	00	00000000
16	10	Week of manufacture (fixed week code)	2E	00101110
17	11	Year of manufacture (fixed year code)	1C	00011100
18	12	EDID structure version ("1")	01	00000001
19	13	EDID revision ("4")	04	00000100
20	14	Video I/P definition ("Digital")	95	10010101
21	15	Active area horizontal ("29.376cm")	1D	00011101
22	16	Active area vertical ("16.524cm")	11	00010001
23	17	Display Gamma (Gamma = "2.2")	78	01111000
24	18	Feature support ("RGB, continous")	03	00000011
25	19	Rx1, Rx0, Ry1, Ry0, Gx1, Gx0, Gy1, Gy0	28	00101000
26	1A	Bx1, Bx0, By1, By0, Wx1, Wx0, Wy1, Wy0	65	01100101
27	1B	Rx=0.590	97	10010111
28	1C	Ry=0.350	59	01011001
29	1D	Gx=0.330	54	01010100
30	1E	Gy=0.555	8E	10001110
31	1F	Bx=0.153	27	00100111
32	20	By=0.119	1E	00011110
33	21	Wx=0.313	50	01010000
34	22	Wy=0.329	54	01010100
35	23	Established timings 1	00	00000000
36	24	Established timings 2	00	00000000
37	25	Manufacturer's reserved timings	00	00000000
38	26	Standard timing ID # 1	01	00000001
39	27	Standard timing ID # 1	01	00000001
40	28	Standard timing ID # 2	01	00000001
41	29	Standard timing ID # 2	01	00000001

42	2A	Standard timing ID # 3	01	00000001
43	2B	Standard timing ID # 3	01	00000001
44	2C	Standard timing ID # 4	01	00000001
45	2D	Standard timing ID # 4	01	00000001
46	2E	Standard timing ID # 5	01	00000001
47	2F	Standard timing ID # 5	01	00000001
48	30	Standard timing ID # 6	01	00000001
49	31	Standard timing ID # 6	01	00000001
50	32	Standard timing ID # 7	01	00000001
51	33	Standard timing ID # 7	01	00000001
52	34	Standard timing ID # 8	01	00000001
53	35	Standard timing ID # 8	01	00000001
54	36	Detailed timing description # 1 Pixel clock ( "152.84"MHz, According to VESA CVT Rev1.4 )	B4	10110100
55	37	# 1 Pixel clock (hex LSB first)	3B	00111011
56	38	# 1 H active ("1920")	80	10000000
57	39	# 1 H blank ("330")	4A	01001010
58	3A	# 1 H active : H blank ("1920 : 330")	71	01110001
59	3B	# 1 V active ("1080")	38	00111000
60	3C	# 1 V blank ("52")	34	00110100
61	3D	# 1 V active : V blank ("1080 : 52")	40	01000000
62	3E	# 1 H sync offset ("46")	2E	00101110
63	3F	# 1 H sync pulse width ("30")	1E	00011110
64	40	# 1 V sync offset : V sync pulse width ("2 : 4")	24	00100100
65	41	# 1 H sync offset : H sync pulse width : V sync offset : V sync width ("46 : 30 : 2 : 4")	00	00000000
66	42	# 1 H image size ("293 mm")	25	00100101
67	43	# 1 V image size ("165 mm")	A5	10100101
68	44	# 1 H image size : V image size	10	00010000
69	45	# 1 H boarder ("0")	00	00000000
70	46	# 1 V boarder ("0")	00	00000000
71	47	Non-interlaced, Normal Display, Digital separate, Positive Hsync, Negative Vsync	1A	00011010
72	48	Detailed timing description # 2 Pixel clock ( "101.88"MHz, According to VESA CVT Rev1.4 )	CC	11001100
73	49	# 2 Pixel clock (hex LSB first)	27	00100111
74	4A	# 2 H active ("1920")	80	10000000
75	4B	# 2 H blank ("330")	4A	01001010
76	4C	# 2 H active : H blank ("1920 : 330")	71	01110001
77	4D	# 2 V active ("1080")	38	00111000
78	4E	# 2 V blank ("52")	34	00110100
79	4F	# 2 V active : V blank ("1080 : 52")	40	01000000
80	50	# 2 H sync offset ("46")	2E	00101110
81	51	# 2 H sync pulse width ("30")	1E	00011110
82	52	# 2 V sync offset : V sync pulse width ("2 : 4")	24	00100100
83	53	# 2 H sync offset : H sync pulse width : V sync offset : V sync width ("46 : 30 : 2 : 4")	00	00000000
84	54	# 2 H image size ("293 mm")	25	00100101
85	55	# 2 V image size ("165 mm")	A5	10100101

86	56	# 2 H image size : V image size	10	00010000
87	57	# 2 H boarder ("0")	00	00000000
88	58	# 2 V boarder ("0")	00	00000000
89	59	Non-interlaced, Normal Display, Digital separate, Positive Hsync, Negative Vsync	1A	00011010
90	5A	NA	00	00000000
91	5B	NA	00	00000000
92	5C	NA	00	00000000
93	5D	NA	00	00000000
94	5E	NA	00	00000000
95	5F	NA	00	00000000
96	60	NA	00	00000000
97	61	NA	00	00000000
98	62	NA	00	00000000
99	63	NA	00	00000000
100	64	NA	00	00000000
101	65	NA	00	00000000
102	66	NA	00	00000000
103	67	NA	00	00000000
104	68	NA	00	00000000
105	69	NA	00	00000000
106	6A	NA	00	00000000
107	6B	NA	00	00000000
108	6C	Detailed Timing Description #4	00	00000000
109	6D	Flags	00	00000000
110	6E	Reserved	00	00000000
111	6F	For Brightness Table and Power Consumption	02	00000010
112	70	Flags	00	00000000
113	71	PWM % [7:0] @ Step 0 = 5%	0C	00001100
114	72	PWM % [7:0] @ Step 5 = 24%	3D	00111101
115	73	PWM % [7:0] @ Step 10 = 100%	FF	11111111
116	74	Nits [7:0] @ Step 0 = 13nits	0D	00001101
117	75	Nits [7:0] @ Step 5 = 60nits	3C	00111100
118	76	Nits [7:0] @ Step 10 = 250nits	7D	01111101
119	77	Panel Electronics Power @32x32 Chess Pattern =680mW	11	00010001
120	78	Backlight Power @60 nits =521mW	0D	00001101
121	79	Backlight Power @Step 10 =2170mW	1B	00011011
122	7A	Nits @ 100% PWM Duty =250nit	7D	01111101
123	7B	Flags	00	00000000
124	7C	Flags	00	00000000
125	7D	Flags	00	00000000
126	7E	Extension flag	00	00000000
127	7F	Checksum	77	01110111

## Appendix. OUTLINE DRAWING

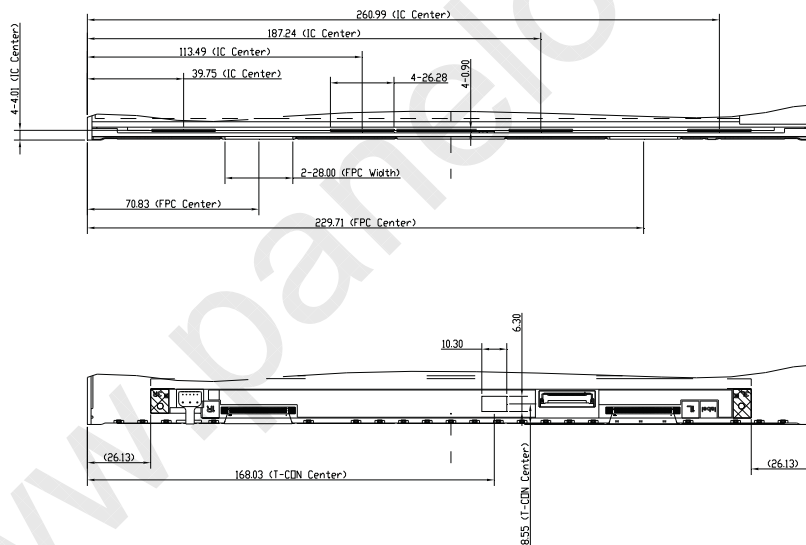
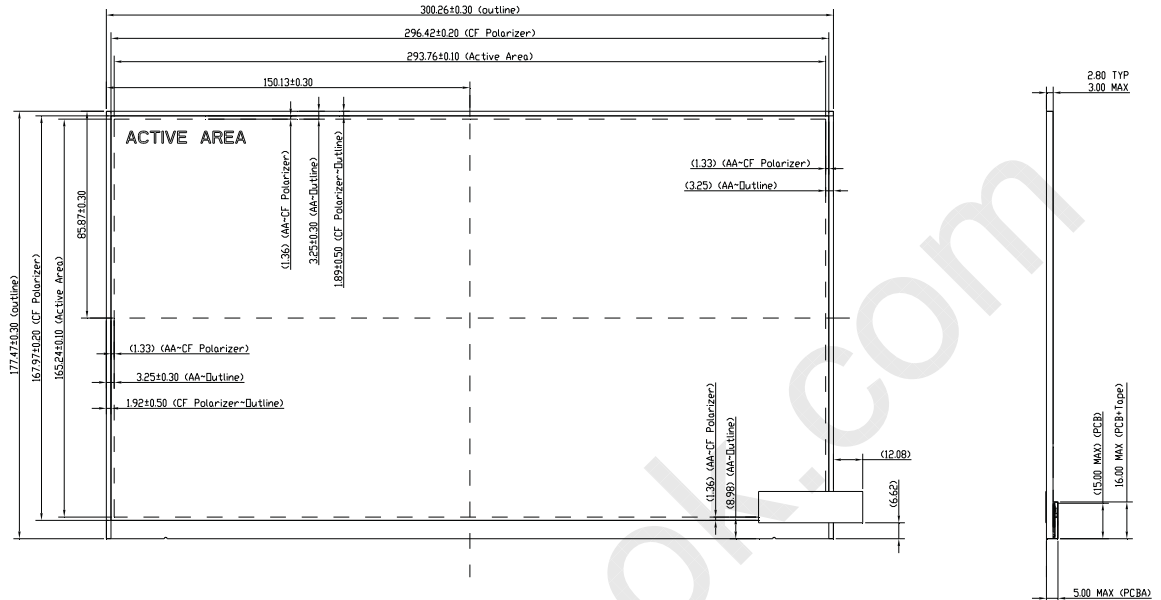

DRIVER IC, FPC, AND TCON LOCATION  
 SEE NOTES FOR EXPLANATION

### NOTES :

1. IN ORDER TO AVOID ABNORMAL DISPLAY, POOLING AND WHITE SPOT, NO OVERLAPPING IS SUGGESTED AT CABLES, ANTENNAS, CAMERA, WLAN, WAN OR FOREIGN OBJECTS OVER FPC, T-CON AND VR LOCATIONS.
2. LVDS/EDP CONNECTOR IS MEASURED AT PIN1 AND ITS MATING LINE.
3. MODULE FLATNESS SPEC (0.5 mm) MAX. (SPEC. WILL BE MODIFIED AFTER DVT CHECK).
4. '( )' MARKS THE REFERENCE DIMENSION.
5. MEASUREMENT OF THICKNESS MUST BE MEASURED BY CALIPER OR MICROMETER.



# PRODUCT SPECIFICATION

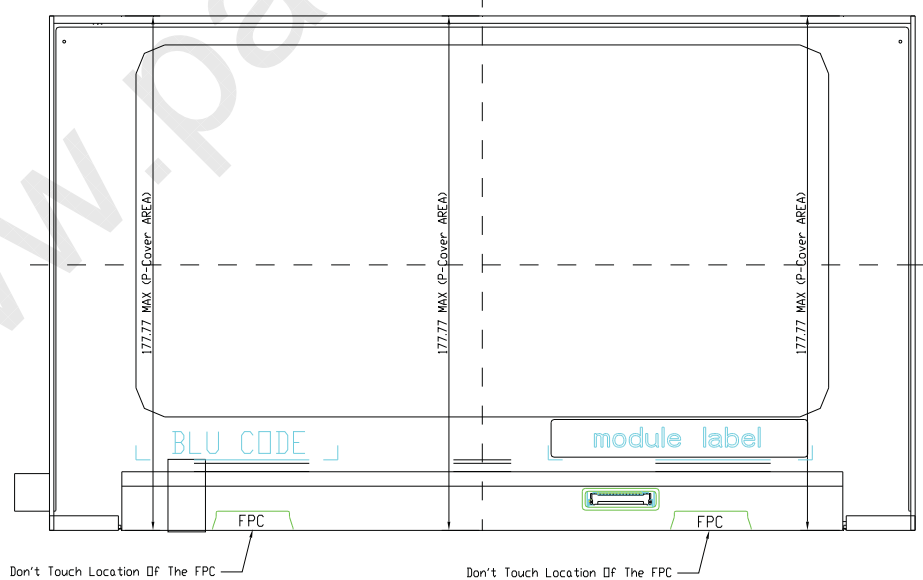
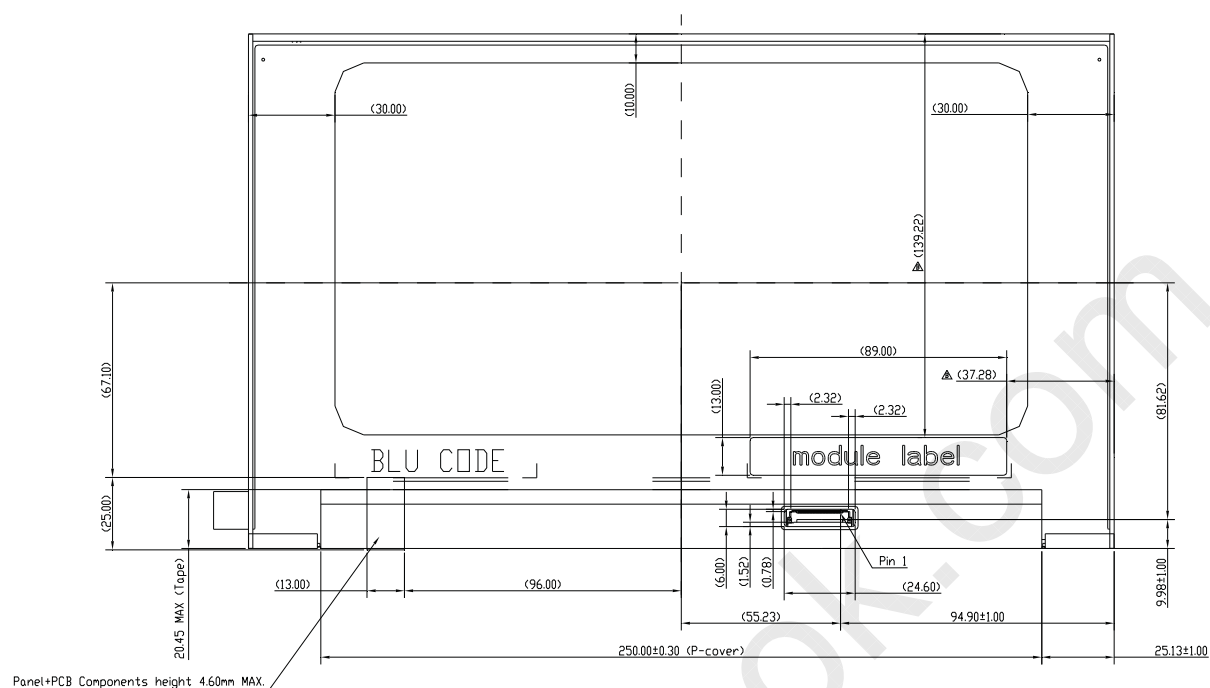



## Appendix. SYSTEM COVER DESIGN GUIDANCE

Ver.7

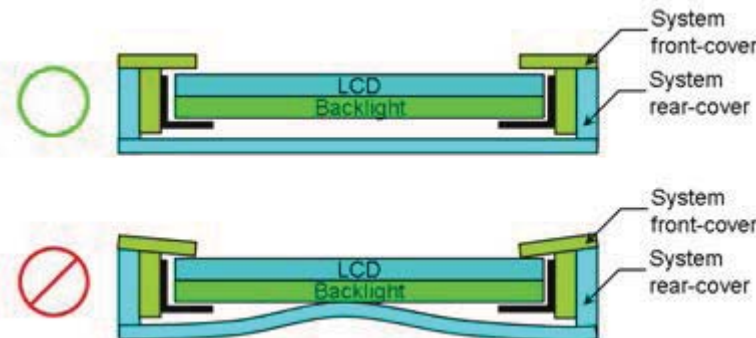
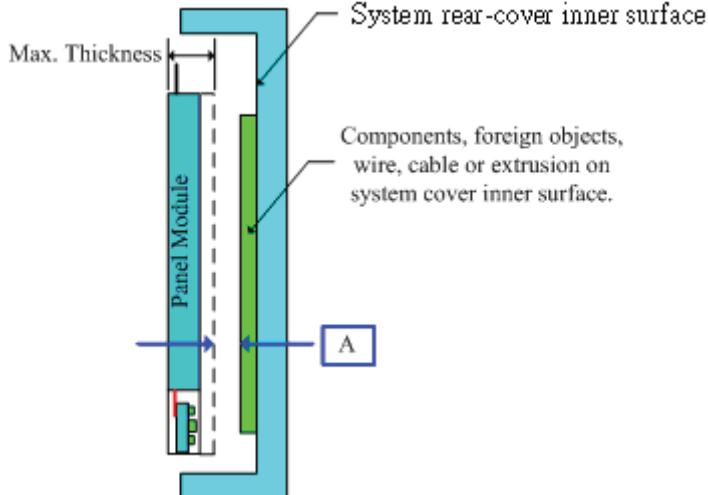
0.	<b>Permanent deformation of system cover after reliability test</b>
	
Definition	<p>System cover including front and rear cover may deform during reliability test. Permanent deformation of system front and rear cover after reliability test should not interfere with panel. Because it may cause issues such as pooling, abnormal display, white spot, and also cell crack.</p> <p>Note: If the interference can not be avoided, please feel free to contact INX FAE Engineer for collaboration design. We can help to verify and pass risk assessment for customer reference.</p>
1.	<b>Design gap A between panel &amp; any components on system rear-cover</b>
	
Definition	<p>Gap between panel's maximum thickness boundary &amp; system's inner surface components such as wire, cable, extrusion is needed for preventing from backpack or pogo test fail. Because zero gap or interference may cause stress concentration. Issues such as pooling, abnormal display, white spot, and cell crack may occur.</p> <p>Maximum flatness of panel and system rear-cover should be taken into account for gap design.</p> <p>Note: If the interference can not be avoided, please feel free to contact INX FAE Engineer for collaboration design. We can help to verify and pass risk assessment for customer reference.</p>
2	<b>Design gap B1 &amp; B2 between panel &amp; protrusions</b>

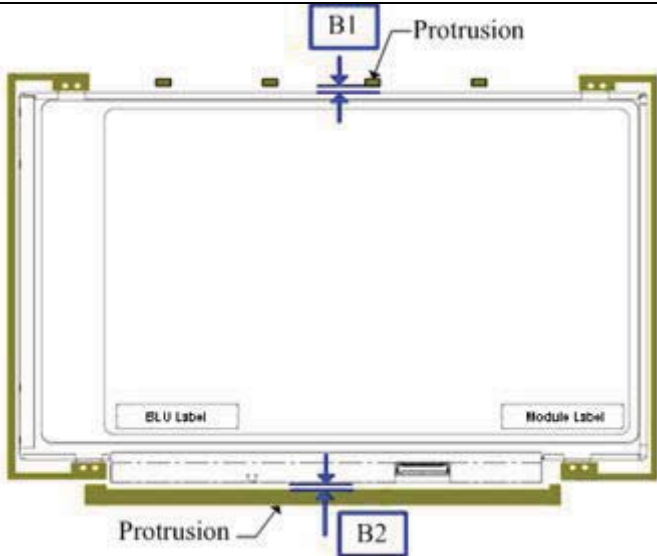
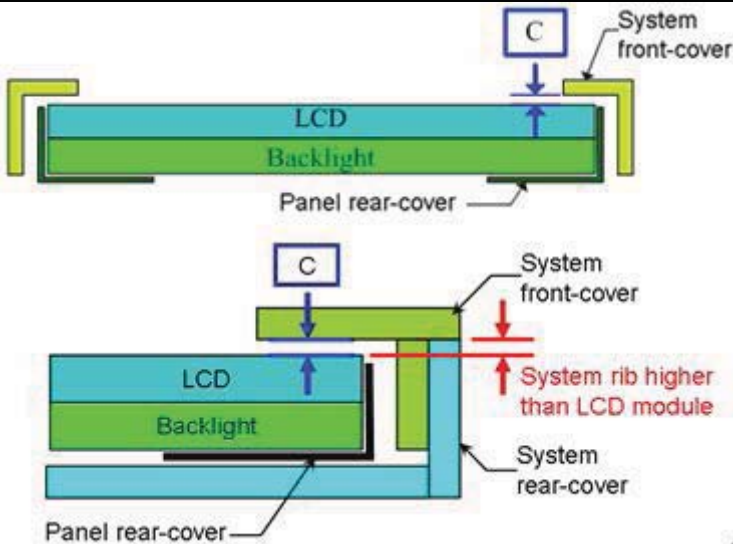
	
<b>Definition</b>	<p>Gap between panel &amp; protrusions is needed to prevent shock test failure. Because protrusions with small gap may hit panel during the test. Issue such as cell crack, abnormal display may occur.</p> <p>The gap should be large enough to absorb the maximum displacement during the test.</p> <p>Note: If the interference can not be avoided, please feel free to contact INX FAE Engineer for collaboration design. We can help to verify and pass risk assessment for customer reference.</p>
<b>3</b>	<b>Design gap C between system front-cover &amp; panel surface.</b>
	
<b>Definition</b>	<p>Gap between system front-cover &amp; panel surface is needed to prevent pooling or glass broken. Zero gap or interference such as burr and warpage from mold frame may cause pooling issue near system front-cover opening edge. This phenomenon is obvious during swing test, hinge test, knock test, or during pooling inspection procedure.</p> <p>To remain sufficient gap, design with system rib higher than maximum panel thickness is recommended.</p> <p>Note: If the interference can not be avoided, please feel free to contact INX FAE Engineer for collaboration design. We can help to verify and pass risk assessment for customer reference.</p>
<b>4</b>	<b>Design gap D1 &amp; D2 between system front-cover &amp; PCB Assembly.</b>

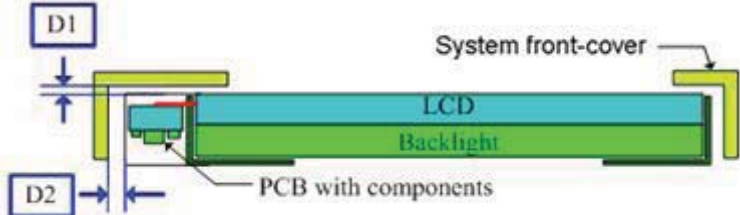
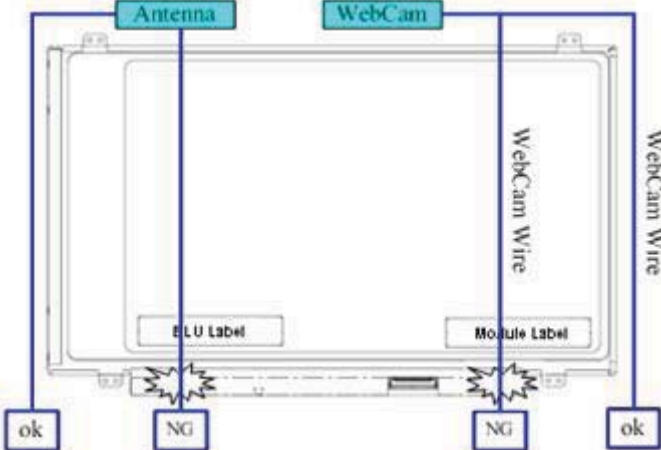
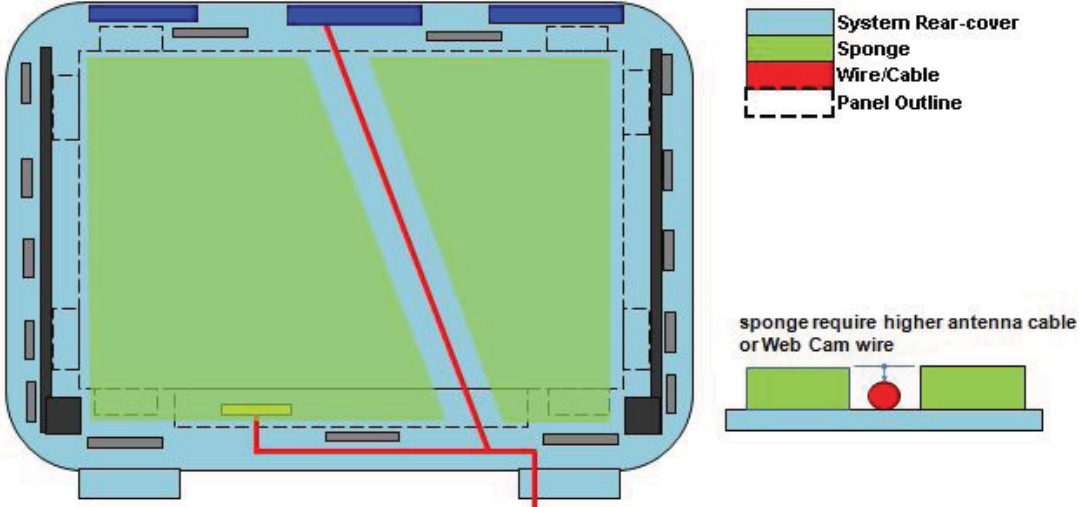
	
<p>Definition</p>	<p>Same as point 2 and 3, but focus on PCBA side.</p>
<p>5</p>	<p><b>Interference examination of antenna cable and WebCam wire</b></p>
	
<p>Definition</p>	<p>Antenna cable or WebCam wire should not overlap with panel outline. Because issue such as abnormal display &amp; white spot after backpack test, hinge test, twist test or pogo test may occur. Note: If the interference can not be avoided, please feel free to contact INX FAE Engineer for collaboration design. We can help to verify and pass risk assessment for customer reference.</p>
<p>6</p>	<p><b>Interference examination of antenna cable and Web Cam wire</b></p>
	
<p>Definition</p>	<p>If the antenna cable or Web Cam wire must overlap with the panel outline, both sides of the antenna cable or Web Cam wire must have a sponge(Sponge material can not contain NH3) and sponge require higher antenna cable or Web Cam wire.( Antenna cable or Web Cam wire should not overlap with TCON,COF/FPC,Driver IC) Note: If the interference can not be avoided, please feel free to contact INX FAE Engineer for collaboration design. We can help to verify and pass risk assessment for customer reference.</p>
<p>7</p>	<p><b>System rear-cover inner surface examination</b></p>

Definition	Burr at logo edge, steps, protrusions or PCB board may cause stress concentration. White spot or glass broken issue may occur during reliability test.
<b>8</b>	<b>Tape/sponge design on system inner surface</b>
Definition	To prevent abnormal display & white spot after scuffing test, hinge test, pogo test, backpack test, tape/sponge should be well covered under panel rear-cover. Because tape/sponge in separate location may act as pressure concentration location.
<b>9</b>	<b>Material used for system rear-cover</b>
Definition	System rear-cover material with high rigidity is needed to resist deformation during scuffing test, hinge test, pogo test, or backpack test. Abnormal display, white spot, pooling issue may occur if low rigidity material is used. Pooling issue may occur because screw's boss positioning for module's bracket are deformed during open-close test. Solid structure design of system rear-cover may also influence the rigidity of system rear-cover. The deformation of system rear-cover should not caused interference.
<b>10</b>	<b>System base unit design near keyboard and mouse pad</b>
Definition	To prevent abnormal display & white spot after scuffing test, hinge test, pogo test, backpack test, sharp edge design in keyboard surface may damage panel during the test. We suggest to use slope edge design, or to reduce the thickness difference of keyboard/mouse pad from the nearby surface.

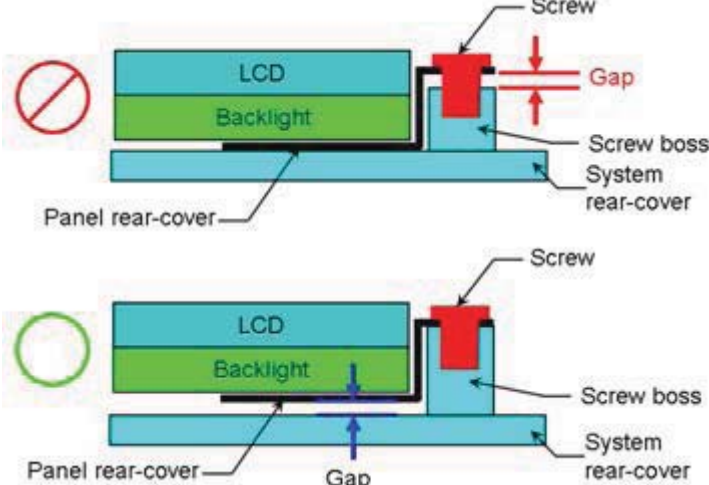
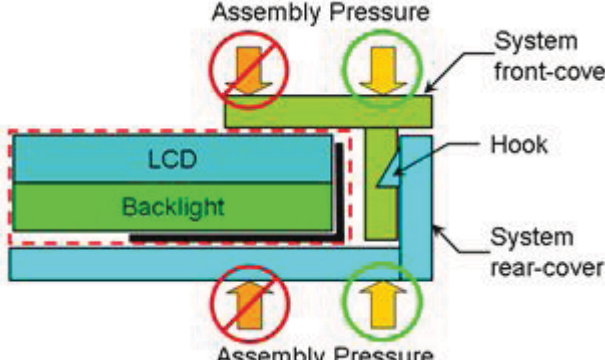
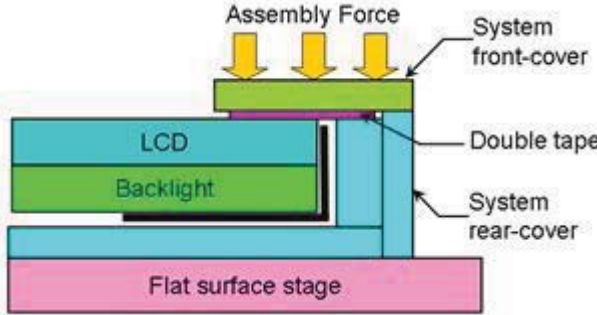

11	<b>Screw boss height design</b>
	 <p>The diagram shows two cross-sectional views of a panel assembly. The top view, marked with a red 'X', shows a screw being inserted into a screw boss on the system rear-cover. The screw boss is shorter than the bracket height, creating a gap between the screw and the bracket. The bottom view, marked with a green circle, shows the screw boss height being equal to or greater than the bracket height, ensuring a proper fit. Labels include: LCD, Backlight, Panel rear-cover, Screw, Gap, Screw boss, System rear-cover.</p>
Definition	<p>Screw boss height should be designed with respect to the height of bracket bottom surface to panel bottom surface + flatness change of panel itself. Because gap will exist between screw boss and bracket, if the screw boss height is smaller. As result while fastening screw, bracket will deformed and pooling issue may occur.</p>
12	<b>Assembly SOP examination for system front-cover with Hook design</b>
	 <p>The diagram shows a cross-section of a panel assembly with a hook design. The system front-cover is being pressed onto the system rear-cover. The hook on the rear-cover fits into the front-cover. Assembly pressure is applied to the front-cover (green circle) and not directly to the hook (red X). Labels include: Assembly Pressure, System front-cover, Hook, System rear-cover, LCD, Backlight.</p>
Definition	<p>To prevent panel crack during system front-cover assembly process with hook design, it is not recommended to press panel or any location that related directly to the panel.</p>
13	<b>Assembly SOP examination for system front-cover with Double tape design</b>
	 <p>The diagram shows a cross-section of a panel assembly with a double tape design. The system front-cover is being pressed onto the system rear-cover. The double tape on the rear-cover fits into the front-cover. Assembly force is applied to the front-cover (green circle) and not directly to the double tape (red X). Labels include: Assembly Force, System front-cover, Double tape, System rear-cover, LCD, Backlight, Flat surface stage.</p>
Definition	<p>To prevent panel crack during system front-cover assembly process with double tape design, it is only allowed to give slight pressure (MAX 3 Kgf/50mm<sup>2</sup>) with large contact area. This can help to distribute the stress and prevent stress concentration. We also suggest putting the system on a flat surface stage to prevent unequal stress distribution during the assembly.</p>
14	<b>System front-cover assembly reference with Double tape design</b>





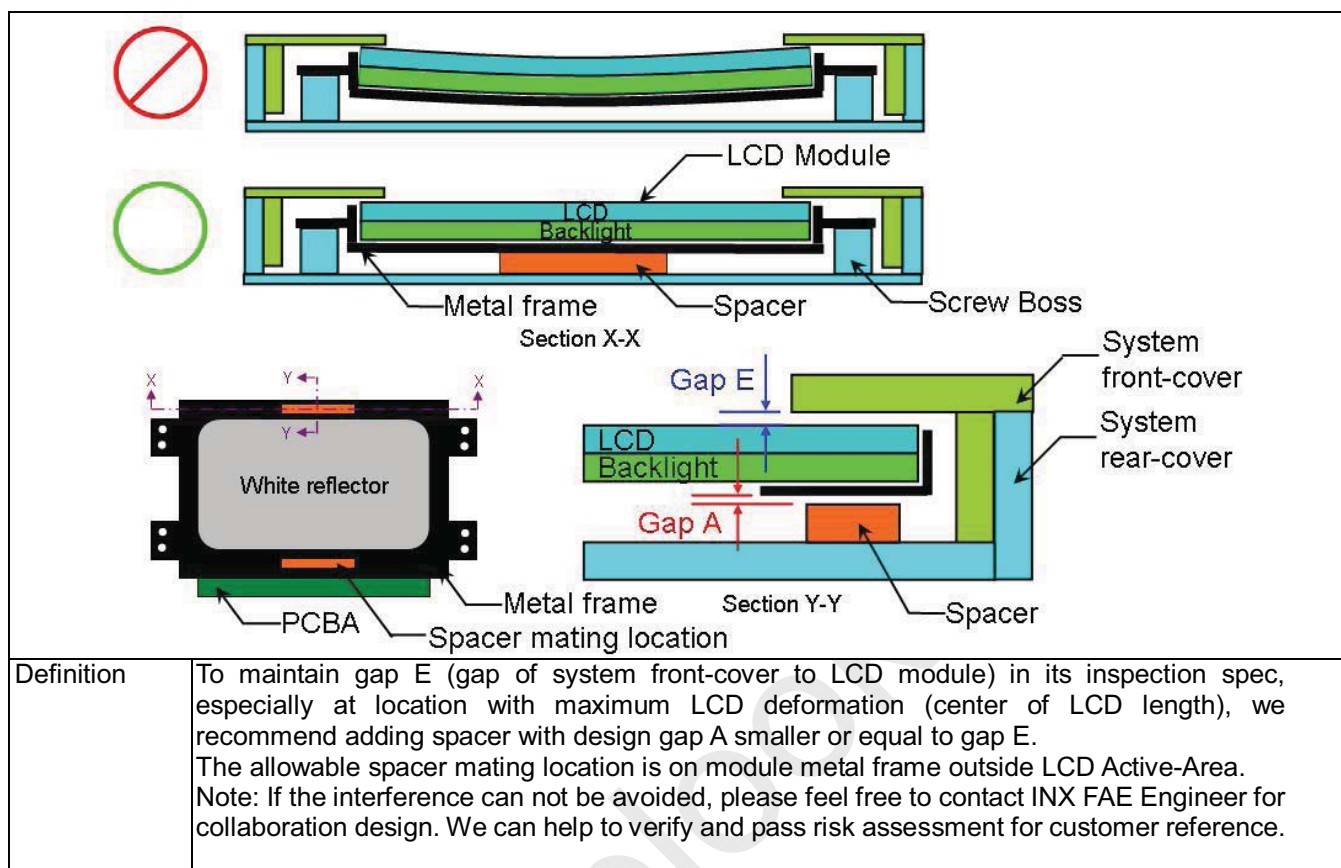













**Appendix. LCD MODULE HANDLING MANUAL**

<p><b>Purpose</b></p>	<ul style="list-style-type: none"> <li>• This SOP is prepared to prevent panel dysfunction possibility through incorrect handling procedure.</li> <li>• This manual provides guide in unpacking and handling steps.</li> <li>• Any person which may contact / related with panel, should follow guide stated in this manual to prevent panel loss.</li> </ul>
<p><b>1.</b></p>	<p><b>Unpacking</b></p>
<div style="display: flex; justify-content: space-around; align-items: center;"> <div style="text-align: center;">  <p>Sealed cardboard box</p> </div> <div style="text-align: center;">  </div> <div style="text-align: center;"> <p>Open carton</p>  </div> <div style="text-align: center;">  </div> <div style="text-align: center;"> <p>Remove EPE Cushion</p>  </div> </div> <div style="text-align: center; margin: 10px 0;">  </div> <div style="display: flex; justify-content: space-around; align-items: center;"> <div style="text-align: center;">  <p>Cut Adhesive Tape</p> </div> <div style="text-align: center;">  </div> <div style="text-align: center;">  <p>Remove EPE Cushion</p> </div> </div> <div style="display: flex; justify-content: space-around; align-items: center;"> <div style="text-align: center;">  <p>Open plastic bag</p> </div> <div style="text-align: center;">  </div> </div>	
<p><b>2.</b></p>	<p><b>Panel Lifting</b></p>

<p><b>Remove PET Cover</b></p> 	<p><b>Remove PE Foam</b></p> 	<p><b>Handle with care (see next page)</b></p> 
		
<p><b>Finger Slot</b></p>		
<p>Use slots at both sides for finger insertion. Handle panel upward with care.</p>		
<p>3.</p>	<p>Do and Don't</p>	
<p>Do :</p>	<p>Don't :</p>	
<ul style="list-style-type: none"> <li>- Handle with both hands.</li> <li>- Handle panel at left and right edge.</li> </ul>	<ul style="list-style-type: none"> <li>- Lifting with one hand.</li> </ul>	
		
	<ul style="list-style-type: none"> <li>- Handle at PCBA side.</li> </ul>	
		

Don't :

- Stack panels.

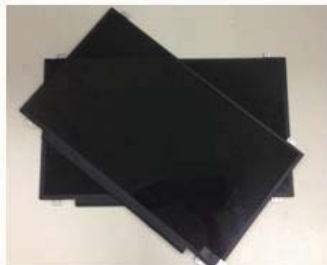

- Press panel.



Don't :

- Put foreign stuff onto panel



- Put foreign stuff under panel



Don't :

- Paste any material unto white reflector sheet



Don't :

- Pull / Push white reflector sheet

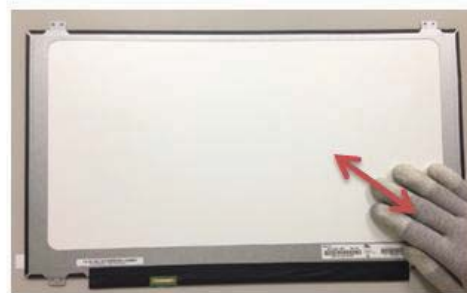

Don't :

- Hold at panel corner.



Don't :

- Twist panel.



Do :

- Hold panel at top edge while inserting connector.



Don't :

- Press white reflector sheet while inserting connector.





Do :

- Remove panel protector film starts from pull tape



Don't :

- Remove panel protector film From film another side.



Don't :

- Touch or Press PCBA Area.

