



Product Specification

G280HVN01.0

AU OPTRONICS CORPORATION

Preliminary Specification

Final Specification

Module	28" Color TFT-LCD (Free Shape LCD)
Model Name	G280HVN01.0

Customer	Date
_____	_____
Checked & Approved by	Date
_____	_____
Note: This Specification is subject to change without notice.	

Approved by	Date
Vito Huang	2013/05/13
Prepared by	Date
Jimmy Tsai	2013/05/13
General Display Business Division / AU Optonics corporation	



Product Specification

G280HVN01.0

AU OPTRONICS CORPORATION

Contents

1. Operating Precautions	4
2. General Description	5
2.1 Display Characteristics	5
2.2 Optical Characteristics	6
3. Functional Block Diagram	9
4. Absolute Maximum Ratings	10
4.1 Absolute Ratings of TFT LCD Module	10
4.2 Absolute Ratings of Environment	10
5. Electrical Characteristics	11
5.1 TFT LCD Module	11
5.2 Backlight Unit	13
6. Signal Characteristic	14
6.1 Pixel Format Image	14
6.2 Signal Description	15
6.3 The Input Data Format	17
6.4 Interface Timing	18
6.5 Power ON/OFF Sequence	20
7. Connector & Pin Assignment	21
7.1 TFT LCD Module: LVDS Connector	21
7.2 Backlight Unit: LED Connector	22
8. Reliability Test	23
9. Mechanical Characteristics	24
10. Label and Packaging	25
10.1 Shipping Label (on the rear side of TFT-LCD display)	25
10.2 Carton Package	25
11. Safety	26
11.1 Sharp Edge Requirements	26
11.2 Materials	26
11.3 Capacitors	26
11.4 National Test Lab Requirement	26



Product Specification

G280HVN01.0

AU OPTRONICS CORPORATION

Record of Revision

Version and Date	Page	Old description	New Description	Remark																																																																																																																														
0.1 2013/03/04	All	First Edition for Customer	All																																																																																																																															
0.2 2013/05/13	5	Power & Weight::TBD	<table border="1"> <tr> <td>Typical Power Consumption</td> <td>[Watt]</td> <td>43.68 W (456 (TFT)*39(LED)W (Typ))</td> </tr> <tr> <td>Weight</td> <td>[gram]</td> <td>1,600 (Max)</td> </tr> </table>	Typical Power Consumption	[Watt]	43.68 W (456 (TFT)*39(LED)W (Typ))	Weight	[gram]	1,600 (Max)																																																																																																																									
Typical Power Consumption	[Watt]	43.68 W (456 (TFT)*39(LED)W (Typ))																																																																																																																																
Weight	[gram]	1,600 (Max)																																																																																																																																
	6	<table border="1"> <tr> <td rowspan="7">Color / Chromaticity Coordinates ± (CIE 1931)</td> <td>Red x₁</td> <td>?</td> </tr> <tr> <td>Red y₁</td> <td>?</td> </tr> <tr> <td>Green x₁</td> <td>?</td> </tr> <tr> <td>Green y₁</td> <td>?</td> </tr> <tr> <td>Blue x₁</td> <td>?</td> </tr> <tr> <td>Blue y₁</td> <td>?</td> </tr> <tr> <td>White x₁</td> <td>0.285</td> </tr> <tr> <td>White y₁</td> <td>0.293</td> </tr> </table>	Color / Chromaticity Coordinates ± (CIE 1931)	Red x ₁	?	Red y ₁	?	Green x ₁	?	Green y ₁	?	Blue x ₁	?	Blue y ₁	?	White x ₁	0.285	White y ₁	0.293	<table border="1"> <tr> <td rowspan="7">Color / Chromaticity Coordinates ± (CIE 1931)</td> <td>Red x₁</td> <td>0.630</td> <td rowspan="7">Typ: ±0.03</td> </tr> <tr> <td>Red y₁</td> <td>0.330</td> </tr> <tr> <td>Green x₁</td> <td>0.320</td> </tr> <tr> <td>Green y₁</td> <td>0.620</td> </tr> <tr> <td>Blue x₁</td> <td>0.150</td> </tr> <tr> <td>Blue y₁</td> <td>0.040</td> </tr> <tr> <td>White x₁</td> <td>0.285</td> </tr> <tr> <td>White y₁</td> <td>0.293</td> </tr> </table>	Color / Chromaticity Coordinates ± (CIE 1931)	Red x ₁	0.630	Typ: ±0.03	Red y ₁	0.330	Green x ₁	0.320	Green y ₁	0.620	Blue x ₁	0.150	Blue y ₁	0.040	White x ₁	0.285	White y ₁	0.293																																																																																												
Color / Chromaticity Coordinates ± (CIE 1931)	Red x ₁	?																																																																																																																																
	Red y ₁	?																																																																																																																																
	Green x ₁	?																																																																																																																																
	Green y ₁	?																																																																																																																																
	Blue x ₁	?																																																																																																																																
	Blue y ₁	?																																																																																																																																
	White x ₁	0.285																																																																																																																																
White y ₁	0.293																																																																																																																																	
Color / Chromaticity Coordinates ± (CIE 1931)	Red x ₁	0.630	Typ: ±0.03																																																																																																																															
	Red y ₁	0.330																																																																																																																																
	Green x ₁	0.320																																																																																																																																
	Green y ₁	0.620																																																																																																																																
	Blue x ₁	0.150																																																																																																																																
	Blue y ₁	0.040																																																																																																																																
	White x ₁	0.285																																																																																																																																
White y ₁	0.293																																																																																																																																	
	13	<table border="1"> <thead> <tr> <th>Symbol</th> <th>Parameter</th> <th>Min.</th> <th>Typ.</th> <th>Max.</th> <th>Unit</th> <th>Remark</th> </tr> </thead> <tbody> <tr> <td>VLED</td> <td>Input Voltage</td> <td>100</td> <td>-</td> <td>-</td> <td>Volt</td> <td>-</td> </tr> <tr> <td>ILED</td> <td>Input Current</td> <td>100</td> <td>-</td> <td>-</td> <td>A</td> <td>100% Dimming</td> </tr> <tr> <td>PLED</td> <td>Power Consumption</td> <td>100</td> <td>-</td> <td>-</td> <td>Watt</td> <td>100% Dimming, Note3</td> </tr> <tr> <td>F_PWM</td> <td>PWM Dimming Frequency</td> <td>100</td> <td>-</td> <td>-</td> <td>Hz</td> <td>-</td> </tr> <tr> <td>-</td> <td>Swing Voltage</td> <td>100</td> <td>-</td> <td>-</td> <td>Volt</td> <td>-</td> </tr> <tr> <td>-</td> <td>Dimming Duty Cycle</td> <td>100</td> <td>-</td> <td>-</td> <td>%</td> <td>-</td> </tr> <tr> <td>V_ANALOG</td> <td>Analog Dimming Voltage</td> <td>100</td> <td>-</td> <td>-</td> <td>-</td> <td>No Analog Dimming</td> </tr> <tr> <td>Operating Life</td> <td>-</td> <td>30000</td> <td>-</td> <td>-</td> <td>Hz</td> <td>Ta=25°C</td> </tr> </tbody> </table>	Symbol	Parameter	Min.	Typ.	Max.	Unit	Remark	VLED	Input Voltage	100	-	-	Volt	-	ILED	Input Current	100	-	-	A	100% Dimming	PLED	Power Consumption	100	-	-	Watt	100% Dimming, Note3	F_PWM	PWM Dimming Frequency	100	-	-	Hz	-	-	Swing Voltage	100	-	-	Volt	-	-	Dimming Duty Cycle	100	-	-	%	-	V_ANALOG	Analog Dimming Voltage	100	-	-	-	No Analog Dimming	Operating Life	-	30000	-	-	Hz	Ta=25°C	<table border="1"> <thead> <tr> <th>Symbol</th> <th>Parameter</th> <th>Min.</th> <th>Typ.</th> <th>Max.</th> <th>Unit</th> <th>Remark</th> </tr> </thead> <tbody> <tr> <td>VLED</td> <td>Input Voltage</td> <td>24.0</td> <td>-</td> <td>-</td> <td>Volt</td> <td>-</td> </tr> <tr> <td>ILED</td> <td>Input Current</td> <td>1.00</td> <td>-</td> <td>-</td> <td>A</td> <td>100% Dimming</td> </tr> <tr> <td>PLED</td> <td>Power Consumption</td> <td>39.0</td> <td>-</td> <td>-</td> <td>Watt</td> <td>100% Dimming, Note3</td> </tr> <tr> <td>F_PWM</td> <td>PWM Dimming Frequency</td> <td>160</td> <td>-</td> <td>-</td> <td>Hz</td> <td>-</td> </tr> <tr> <td>-</td> <td>Swing Voltage</td> <td>0</td> <td>-</td> <td>5</td> <td>Volt</td> <td>-</td> </tr> <tr> <td>-</td> <td>Dimming Duty Cycle</td> <td>5</td> <td>-</td> <td>100</td> <td>%</td> <td>-</td> </tr> <tr> <td>V_ANALOG</td> <td>Analog Dimming Voltage</td> <td>NA</td> <td>-</td> <td>-</td> <td>-</td> <td>No Analog Dimming</td> </tr> <tr> <td>Operating Life</td> <td>-</td> <td>30000</td> <td>-</td> <td>-</td> <td>Hz</td> <td>Ta=25°C</td> </tr> </tbody> </table>	Symbol	Parameter	Min.	Typ.	Max.	Unit	Remark	VLED	Input Voltage	24.0	-	-	Volt	-	ILED	Input Current	1.00	-	-	A	100% Dimming	PLED	Power Consumption	39.0	-	-	Watt	100% Dimming, Note3	F_PWM	PWM Dimming Frequency	160	-	-	Hz	-	-	Swing Voltage	0	-	5	Volt	-	-	Dimming Duty Cycle	5	-	100	%	-	V_ANALOG	Analog Dimming Voltage	NA	-	-	-	No Analog Dimming	Operating Life	-	30000	-	-	Hz	Ta=25°C	
Symbol	Parameter	Min.	Typ.	Max.	Unit	Remark																																																																																																																												
VLED	Input Voltage	100	-	-	Volt	-																																																																																																																												
ILED	Input Current	100	-	-	A	100% Dimming																																																																																																																												
PLED	Power Consumption	100	-	-	Watt	100% Dimming, Note3																																																																																																																												
F_PWM	PWM Dimming Frequency	100	-	-	Hz	-																																																																																																																												
-	Swing Voltage	100	-	-	Volt	-																																																																																																																												
-	Dimming Duty Cycle	100	-	-	%	-																																																																																																																												
V_ANALOG	Analog Dimming Voltage	100	-	-	-	No Analog Dimming																																																																																																																												
Operating Life	-	30000	-	-	Hz	Ta=25°C																																																																																																																												
Symbol	Parameter	Min.	Typ.	Max.	Unit	Remark																																																																																																																												
VLED	Input Voltage	24.0	-	-	Volt	-																																																																																																																												
ILED	Input Current	1.00	-	-	A	100% Dimming																																																																																																																												
PLED	Power Consumption	39.0	-	-	Watt	100% Dimming, Note3																																																																																																																												
F_PWM	PWM Dimming Frequency	160	-	-	Hz	-																																																																																																																												
-	Swing Voltage	0	-	5	Volt	-																																																																																																																												
-	Dimming Duty Cycle	5	-	100	%	-																																																																																																																												
V_ANALOG	Analog Dimming Voltage	NA	-	-	-	No Analog Dimming																																																																																																																												
Operating Life	-	30000	-	-	Hz	Ta=25°C																																																																																																																												
	25	Carton Package: TBD	Carton Package: Defined																																																																																																																															



Product Specification

G280HVN01.0

AU OPTRONICS CORPORATION

1. Operating Precautions

- 1) Since front polarizer is easily damaged, pay attention not to scratch it.
- 2) Be sure to turn off power supply when inserting or disconnecting from input connector.
- 3) Wipe off water drop immediately. Long contact with water may cause discoloration or spots.
- 4) When the panel surface is soiled, wipe it with absorbent cotton or other soft cloth.
- 5) Since the panel is made of glass, it may break or crack if dropped or bumped on hard surface.
- 6) Since CMOS LSI is used in this module, take care of static electricity and insure human earth when handling.
- 7) Do not open or modify the Module Assembly.
- 8) In case if a Module has to be put back into the packing container slot after once it was taken out from the container, take it easily, or the TFT Module may be damaged.
- 9) At the insertion or removal of the Signal Interface Connector, be sure not to rotate nor tilt the Interface Connector of the TFT Module.
- 10) After installation of the TFT Module into an enclosure, do not twist nor bend the TFT Module even momentary. At designing the enclosure, it should be taken into consideration that no bending/twisting forces are applied to the TFT Module from outside. Otherwise the TFT Module may be damaged.
- 11) Small amount of materials having no flammability grade is used in the LCD module. The LCD module should be supplied by power complied with requirements of Limited Power Source (IEC60950 or UL1950), or be applied exemption.
- 12) Severe temperature condition may result in different luminance, response time and LED life time.
- 13) The data on this specification sheet is applicable when LCD module is placed in landscape position.
- 14) Continuous displaying fixed pattern may induce image sticking. It is recommended to use screen saver or shuffle content periodically if fixed pattern is displayed on the screen.



Product Specification

G280HVN01.0

AU OPTRONICS CORPORATION

2. General Description

This specification applies to the 28 inch-wide Color TFT-LCD Module G280HVN01.0.

The display supports the 1920(H) x 360(V) screen format and 16.7M colors. All input signals are 2 Channels LVDS interface compatible.

LED driver board is included. G280HVN01.0 is designed for industrial display applications.

2.1 Display Characteristics

The following items are characteristics summary on the table under 25 °C condition:

Items	Unit	Specifications
Screen Diagonal	[inch]	28
Active Area	[mm]	698.3 (H) x 130.9(V)
Pixels H x V		1920(x3) x 360
Pixel Pitch	[mm]	0.3637 (per one triad) x 0.3637
Pixel Arrangement		R.G.B. Vertical Stripe
Display Mode		Normally Black
Nominal Input Voltage VDD	[Volt]	+12 V
Typical Power Consumption	[Watt]	43.68 W (4.68 (TFT)+ 39 (LED) W (Typ))
Weight	[Grams]	1,600 (Max)
Physical Size	[mm]	725.98 (H) x 158.90 (V) x 27.6 (D)
Electrical Interface		Dual Channel LVDS
Surface Treatment		Anti-glare, Hardness 3H
Support Color		16.7M colors (8-bits)
Temperature Range Operating	[°C]	0 to +50
Storage (Non-Operating)	[°C]	-20 to +60
RoHS Compliance		RoHS Compliance



Product Specification

G280HVN01.0

AU OPTRONICS CORPORATION

2.2 Optical Characteristics

The optical characteristics are measured under stable conditions at 25°C (Room Temperature):

Item	Unit	Conditions	Min.	Typ.	Max.	Note
White Luminance	[cd/m ²]	I _F = 80mA	480	600	-	1
Uniformity	%	9 Points	75	80	-	1, 2, 3
Contrast Ratio			2400	3000	-	4
Cross talk	%		-	-	1.5	5
Response Time	[msec]	Gray to Gray	-	6.5	-	6
Viewing Angle	[degree] [degree]	Horizontal (Right) CR = 10 (Left)	-	89	-	7
	[degree] [degree]	Vertical (Upper) CR = 10 (Lower)	-	89	-	
Color / Chromaticity Coordinates (CIE 1931)		Red x	Typ.-0.03	0.630	Typ.+0.03	
		Red y		0.330		
		Green x		0.320		
		Green y		0.620		
		Blue x		0.150		
		Blue y		0.040		
		White x		0.285		
		White y		0.293		

Note 1: Measurement method

Equipment Pattern Generator, Power Supply, Digital Voltmeter, Luminance meter (SR_3 or equivalent)

Aperture 1° with 50cm viewing distance

Test Point Center

Environment < 1 lux

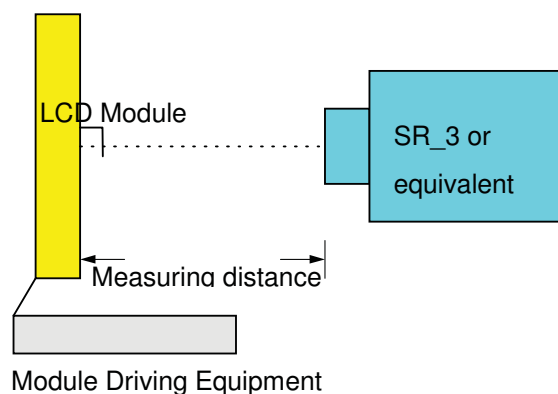



Product Specification

G280HVN01.0

AU OPTRONICS CORPORATION

Note 2: Definition of 9 points position (Display active area)

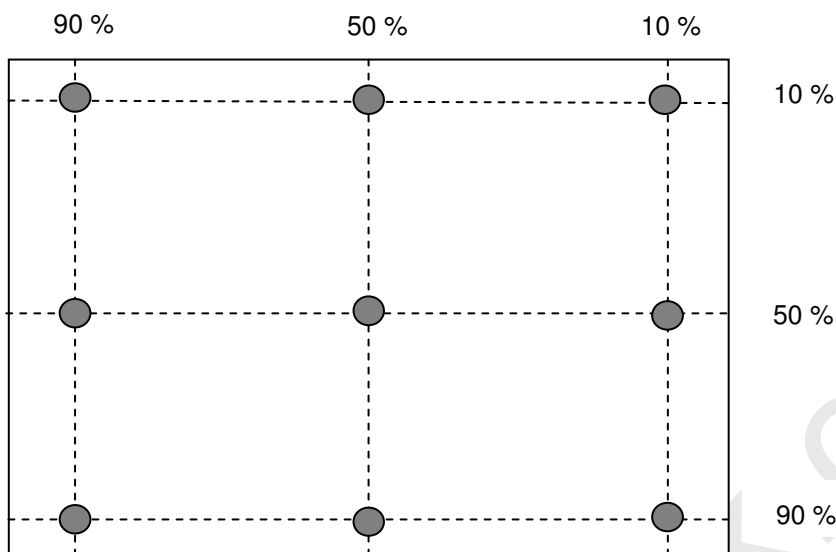

Note 3: The luminance uniformity of 9 points is defined by dividing the minimum luminance values by the maximum test point luminance

$$\delta_{w9} = \frac{\text{Minimum Brightness of nine points}}{\text{Maximum Brightness of nine points}}$$

Note 4 : Definition of contrast ratio (CR):

$$\text{Contrast ratio (CR)} = \frac{\text{Brightness on the "White" state}}{\text{Brightness on the "Black" state}}$$

Note 5 : Definition of cross talk (CT)

$$CT = |YB - YA| / YA \times 100 (\%)$$

Where

YA = Luminance of measured location without gray level 255 pattern (cd/m2)

YB = Luminance of measured location with gray level 255 pattern (cd/m2)

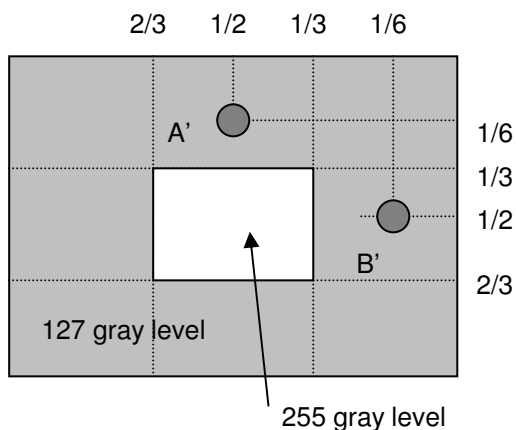
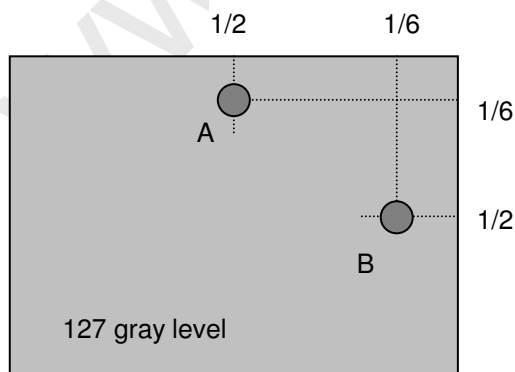



Product Specification

G280HVN01.0

AU OPTRONICS CORPORATION

Note 6: Definition of response time:

The output signals of photo detector are measured when the input signals are changed from "White" to "Black" (falling time) and from "Black" to "White" (rising time), respectively. The response time interval is between 10% and 90% of amplitudes. Please refer to the figure as below.

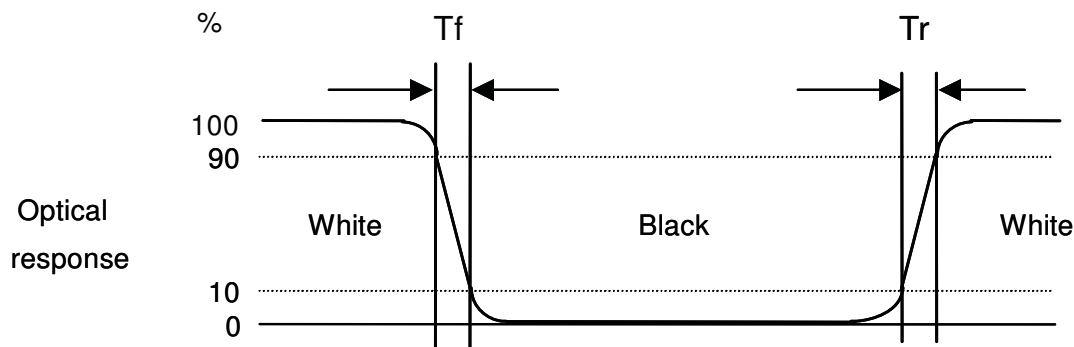

Note 7: Definition of viewing angle

Viewing angle is the measurement of contrast ratio ≥ 10 , at the screen center, over a 180° horizontal and 180° vertical range (off-normal viewing angles). The 180° viewing angle range is broken down as below: 90° (θ) horizontal left and right, and 90° (Φ) vertical high (up) and low (down). The measurement direction is typically perpendicular to the display surface with the screen rotated to its center to develop the desired measurement viewing angle.

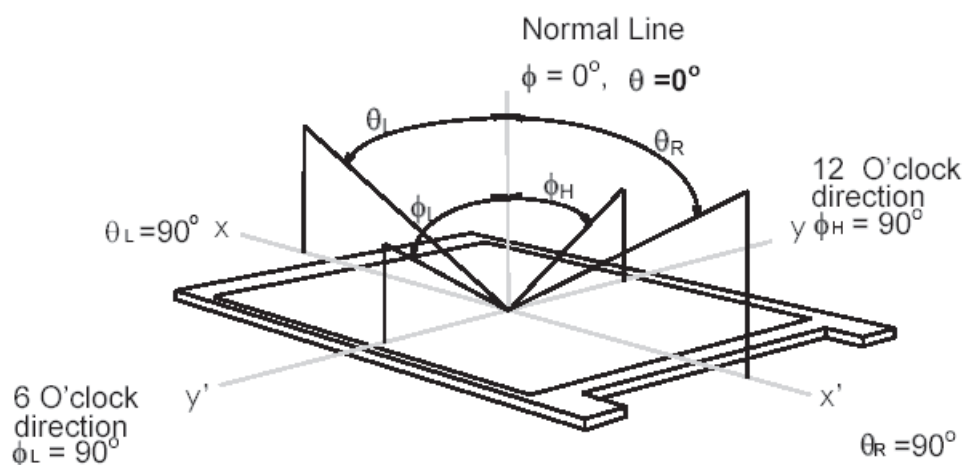



Product Specification

G280HVN01.0

AU OPTRONICS CORPORATION

3. Functional Block Diagram

The following diagram shows the functional block of the 28 inches wide Color TFT-LCD Module:

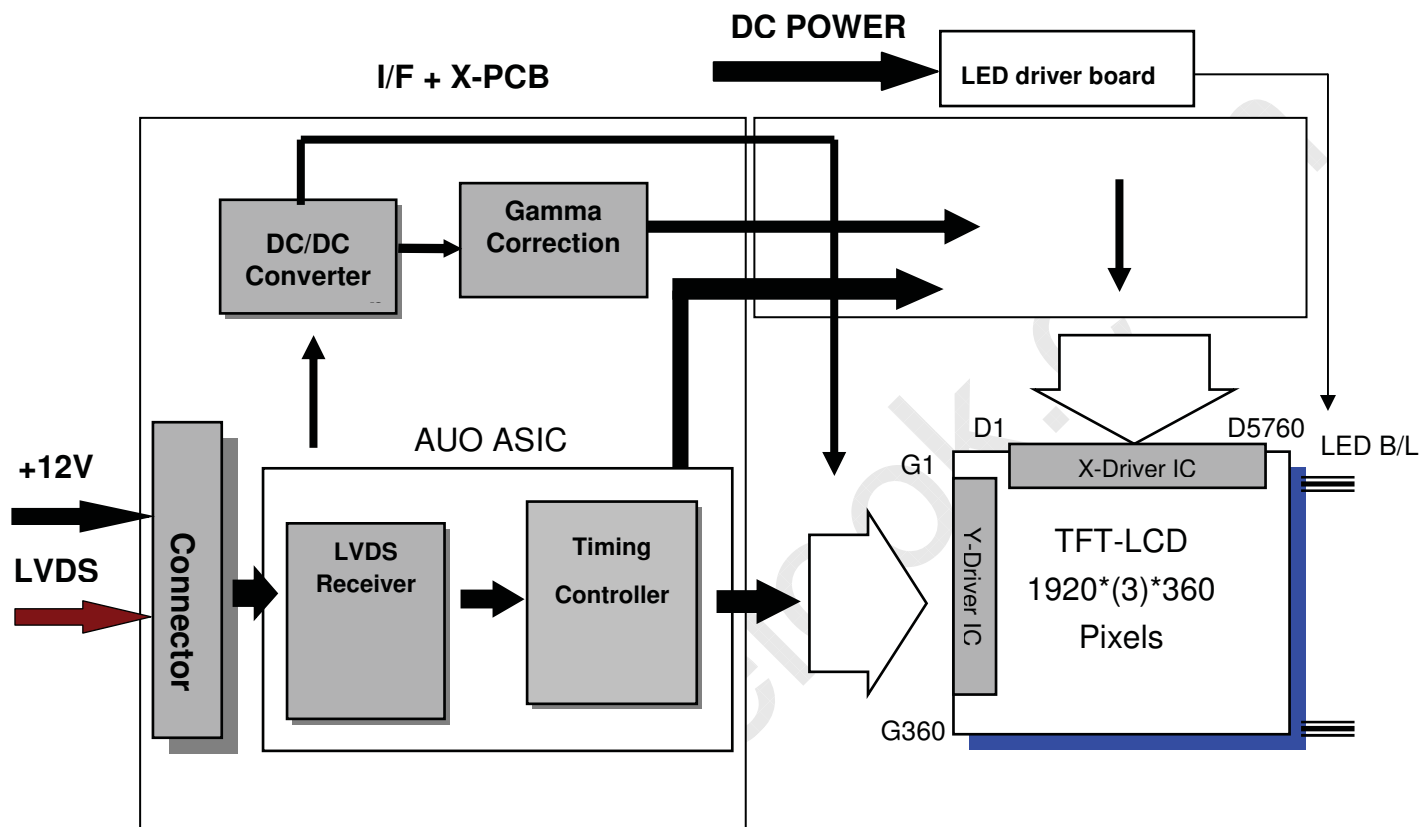

LVDS Connector: JAE (FI-RE51S-HF)

LED Connector: CviLux (CI0114M1HR0-LF)



Product Specification

G280HVN01.0

AU OPTRONICS CORPORATION

4. Absolute Maximum Ratings

4.1 Absolute Ratings of TFT LCD Module

Item	Symbol	Min	Max	Unit
Logic/LCD Drive Voltage	VDD	-0.3	14	[Volt]

4.2 Absolute Ratings of Environment

Item	Symbol	Min	Max	Unit
Operating Temperature	TOP	0	+50	[°C]
Operation Humidity	HOP	10	90	[%RH]
Storage Temperature	TST	-20	+60	[°C]
Storage Humidity	HST	10	90	[%RH]

Note: Maximum Wet-Bulb should be 39°C and no condensation.

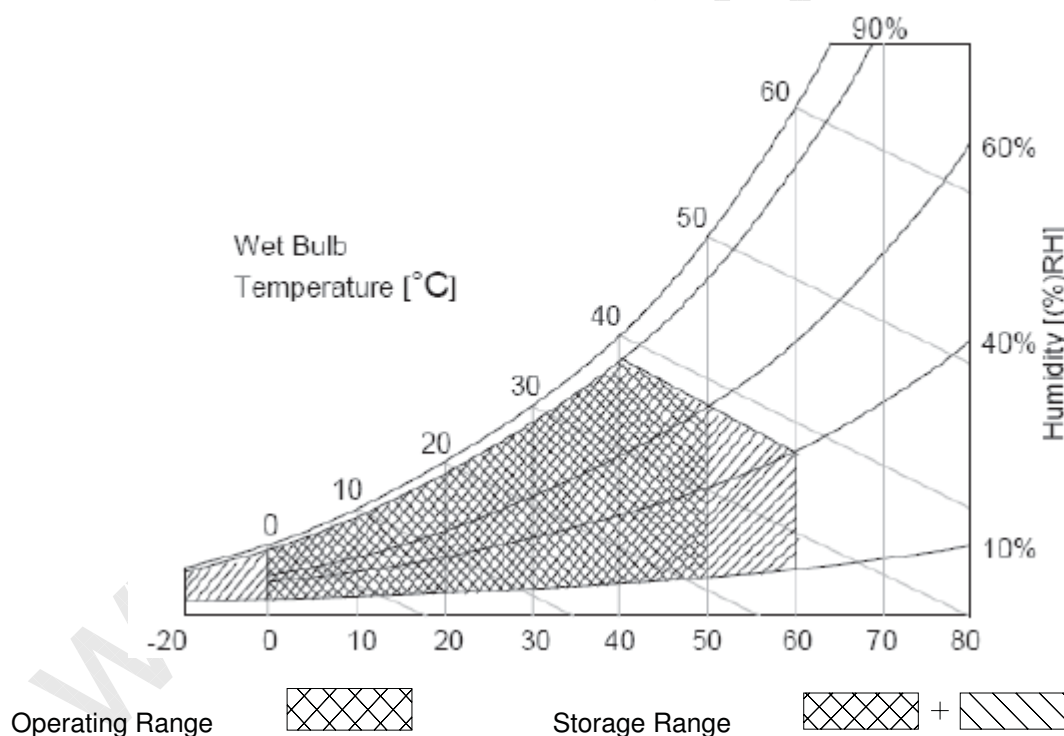



Product Specification

G280HVN01.0

AU OPTRONICS CORPORATION

5. Electrical Characteristics

5.1 TFT LCD Module

5.1.1 Power Specification

Symbol	Parameter	Min	Typ	Max	Units	Remark
VDD	Logic/LCD Drive Voltage	10,8	12	13.2	[Volt]	± 10%
IDD	VDD Current	-	0.39	0.56	[A]	VDD= 5.0V, All White Pattern At 60Hz
PDD	VDD Power	-	4.68	-	[Watt]	VDD= 5.0V, All White Pattern At 60Hz

Measurement condition:

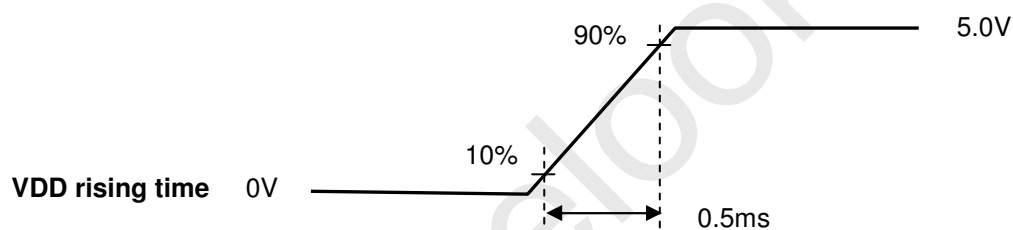



Product Specification

G280HVN01.0

AU OPTRONICS CORPORATION

5.1.2 Signal Electrical Characteristics

Input signals shall be low or Hi-Z state when VDD is off.

Symbol	Item	Min.	Typ.	Max.	Unit	Remark
VTH	Differential Input High Threshold	+100	-	+300	[mV]	VCM=1.2V
VTL	Differential Input Low Threshold	-300	-	-100	[mV]	VCM=1.2V
VID	Input Differential Voltage	200	400	600	[mV]	
VICM	Differential Input Common Mode Voltage	1.1	1.25	1.4	[V]	VTH/VTL=±100mV

Note: LVDS Signal Waveform.

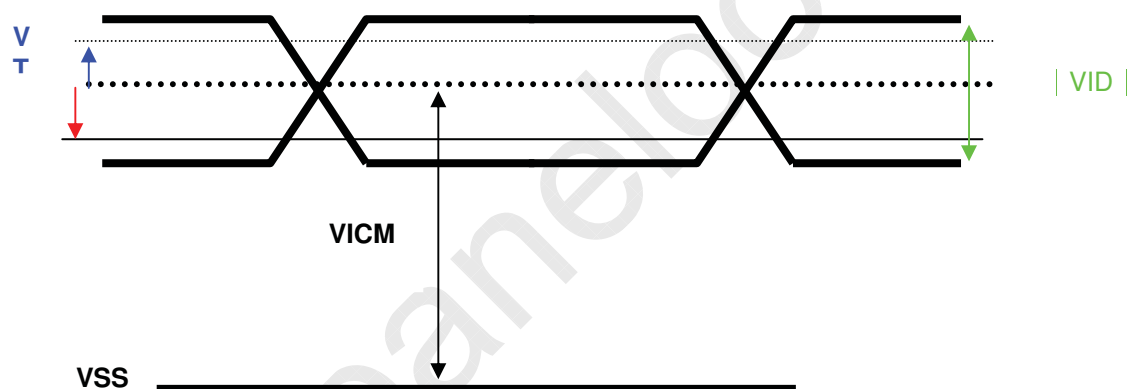



Product Specification

G280HVN01.0

AU OPTRONICS CORPORATION

5.2 Backlight Unit

5.2.1 LED Light Bar

Following characteristics are measured under stable condition at 25°C (Room Temperature).

Symbol	Parameter	Min	Typ	Max	Unit	Remark
VLED	Input Voltage		24.0		Volt	
ILED	Input Current		1.63		A	100% Dimming
PLED	Power Consumption		39.0		Watt	100% Dimming, Note3
FPWM	PWM Dimming Frequency		160		Hz	
	Swing Voltage	0		5	Volt	
	Dimming Duty Cycle	5		100	%	
Vanalog	Analog Dimming Voltage		NA			No Analog Dimming
Operating Life		30,000	-	-	Hrs	Ta = 25°C

Note 1: Ta means ambient temperature of TFT-LCD module,

Note 2: If module is driven by high current or at high ambient temperature & humidity condition. The operating life will be reduced.

Note 3: LED light bar structure: (2 strings x 20 pcs / string x 2 Light bar= 80 pcs of LED)

Note 4: Operating life means brightness goes down to 50% initial brightness. Typical operating life time is estimated data.



Product Specification

G280HVN01.0

AU OPTRONICS CORPORATION

6. Signal Characteristic

6.1 Pixel Format Image

Following figure shows the relationship of the input signals and LCD pixel format.. Although this panel resolution is 1920x360, please input 1920x1080 format signal to it. And data after line 360 (includde 360), all should be set to "black" command.

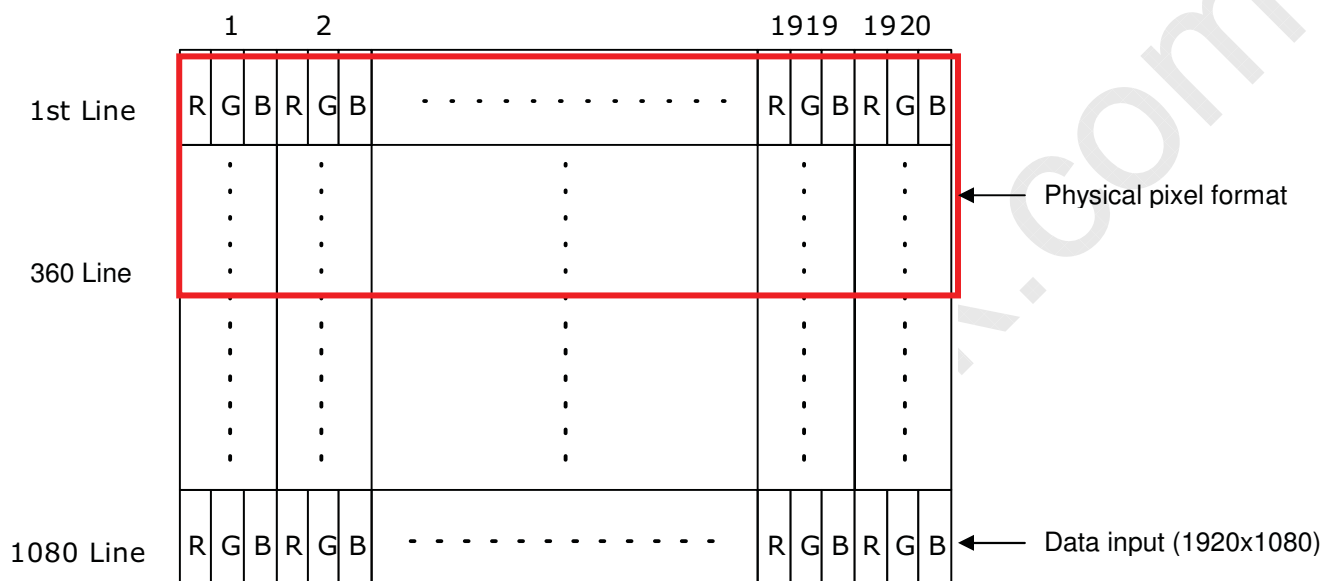



Product Specification

G280HVN01.0

AU OPTRONICS CORPORATION

6.2 Signal Description

- LCD connector: FI-RE51S-HF (JAE, LVDS connector)

PIN #	SIGNAL NAME	DESCRIPTION
1	Open	No connection (Internal Open)
2	N.C.	AUO Internal Use Only
3	N.C.	AUO Internal Use Only
4	N.C.	AUO Internal Use Only
5	N.C.	AUO Internal Use Only
6	N.C.	AUO Internal Use Only
7	LVDS_SEL	Open / High(3.3V) for NS, Low(GND) for JEIDA
8	N.C.	No connection (Internal Open)
9	N.C.	No connection
10	GND	Ground
11	GND	Ground
12	CH1_0-	LVDS Channel 1, Signal 0-
13	CH1_0+	LVDS Channel 1, Signal 0+
14	CH1_1-	LVDS Channel 1, Signal 1-
15	CH1_1+	LVDS Channel 1, Signal 1+
16	CH1_2-	LVDS Channel 1, Signal 2-
17	CH1_2+	LVDS Channel 1, Signal 2+
18	GND	Ground
19	CH1_CLK-	LVDS Channel 1, Clock -
20	CH1_CLK+	LVDS Channel 1, Clock +
21	GND	Ground
22	CH1_3-	LVDS Channel 1, Signal 3-
23	CH1_3+	LVDS Channel 1, Signal 3+
24	N.C.	AUO Internal Use Only
25	N.C.	AUO Internal Use Only
26	GND	Ground
27	GND	Ground
28	CH2_0-	LVDS Channel 2, Signal 0-
29	CH2_0+	LVDS Channel 2, Signal 0+
30	CH2_1-	LVDS Channel 2, Signal 1-
31	CH2_1+	LVDS Channel 2, Signal 1+
32	CH2_2-	LVDS Channel 2, Signal 2-



Product Specification

G280HVN01.0

AU OPTRONICS CORPORATION

33	CH2_2+	LVDS Channel 2, Signal 2+
34	GND	Ground
35	CH2_CLK-	LVDS Channel 2, Clock -
36	CH2_CLK+	LVDS Channel 2, Clock +
37	GND	Ground
38	CH2_3-	LVDS Channel 2, Signal 3-
39	CH2_3+	LVDS Channel 2, Signal 3+
40	N.C.	AUO Internal Use Only
41	N.C.	AUO Internal Use Only
42	GND	Ground
43	GND	Ground
44	GND	Ground
45	GND	Ground
46	GND	Ground
47	N.C.	No connection
48	VDC	Power Supply, +12V DC Regulated
49	VDC	Power Supply, +12V DC Regulated
50	VDC	Power Supply, +12V DC Regulated
51	VDC	Power Supply, +12V DC Regulated



Product Specification

G280HVN01.0

AU OPTRONICS CORPORATION

6.3 The Input Data Format

■ LVDS Option = High/Open → NS

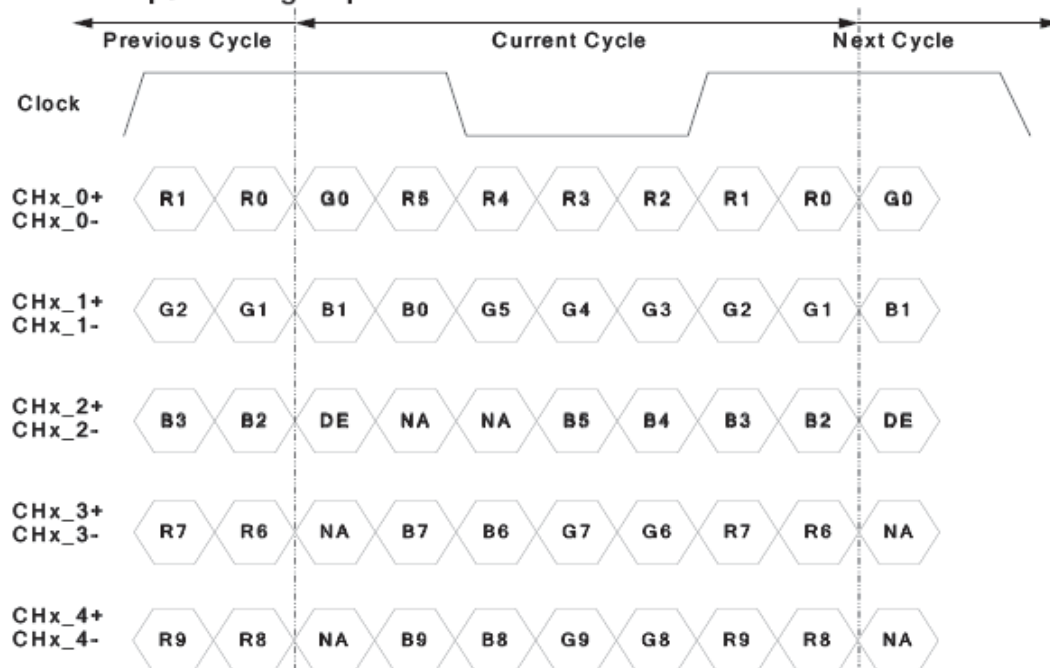

Note: x = 1, 2, 3, 4...

■ LVDS Option = Low → JEIDA

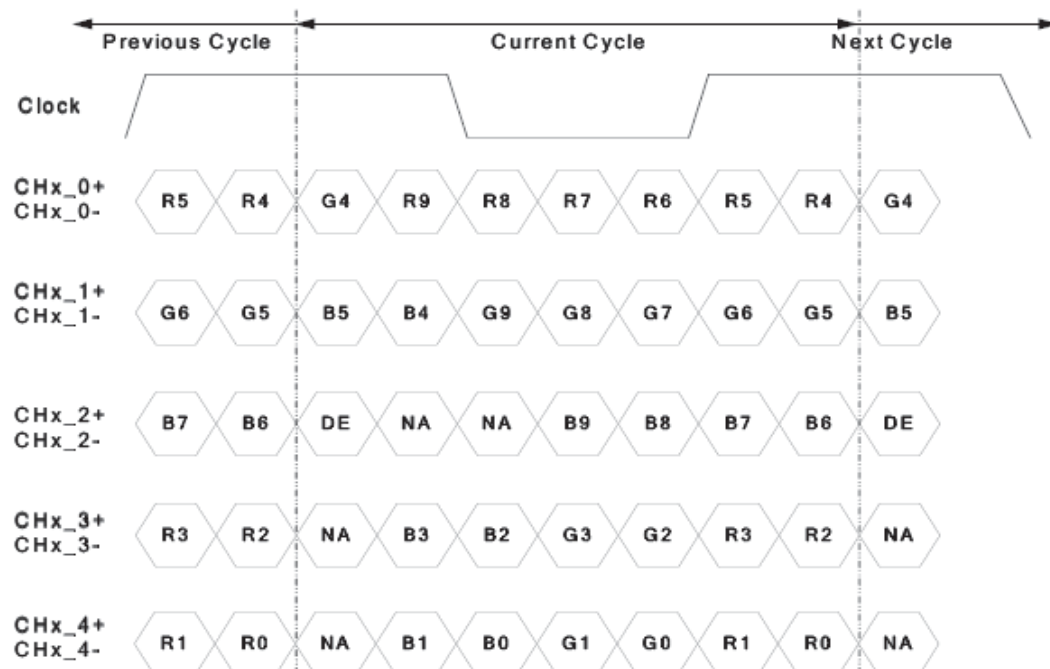

Note: x = 1, 2, 3, 4...



Product Specification

G280HVN01.0

AU OPTRONICS CORPORATION

6.4 Interface Timing

6.4.1 Timing Characteristics

Signal	Item	Symbol	Min	Typ	Max	Unit
Clock	Frequency	$1/T_{\text{Clock}}$	50	74.25	82	MHz
Frame Rate	Frequency	$1/T_v$	47	60	63	Hz
Vertical Section	Period	T_v	1096	1125	1480	T_line
	Active	T_{vD}	-	1080	-	
	Blanking	T_{vB}	16	45	400	
Horizontal Section	Period	T_H	1030	1100	1325	T_clock
	Active	T_{HD}	-	960	-	
	Blanking	T_{HB}	70	140	365	

Note: DE mode onl



Product Specification

G280HVN01.0

AU OPTRONICS CORPORATION

6.4.2 Input Timing Diagram

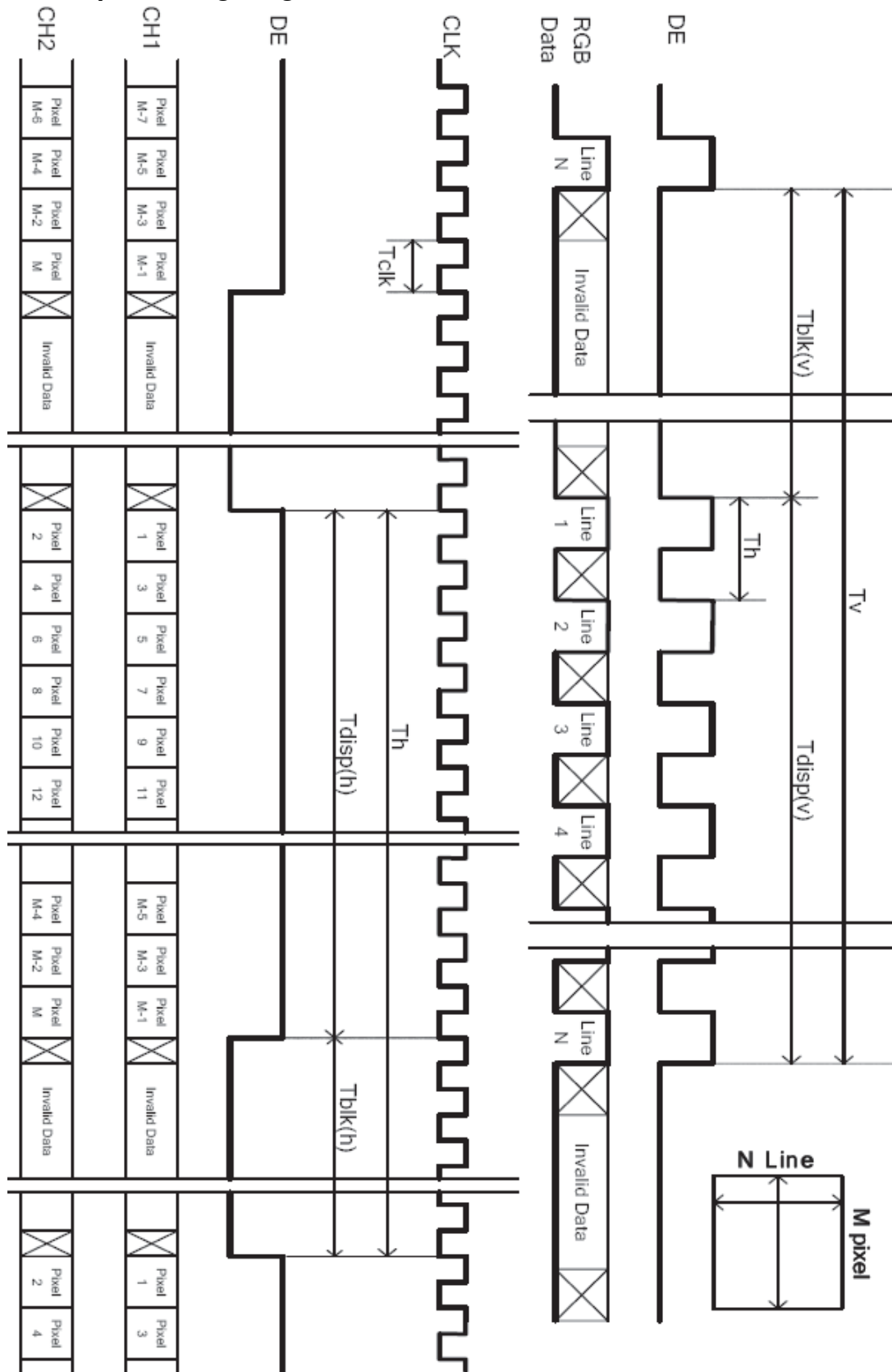



Product Specification

G280HVN01.0

AU OPTRONICS CORPORATION

6.5 Power ON/OFF Sequence

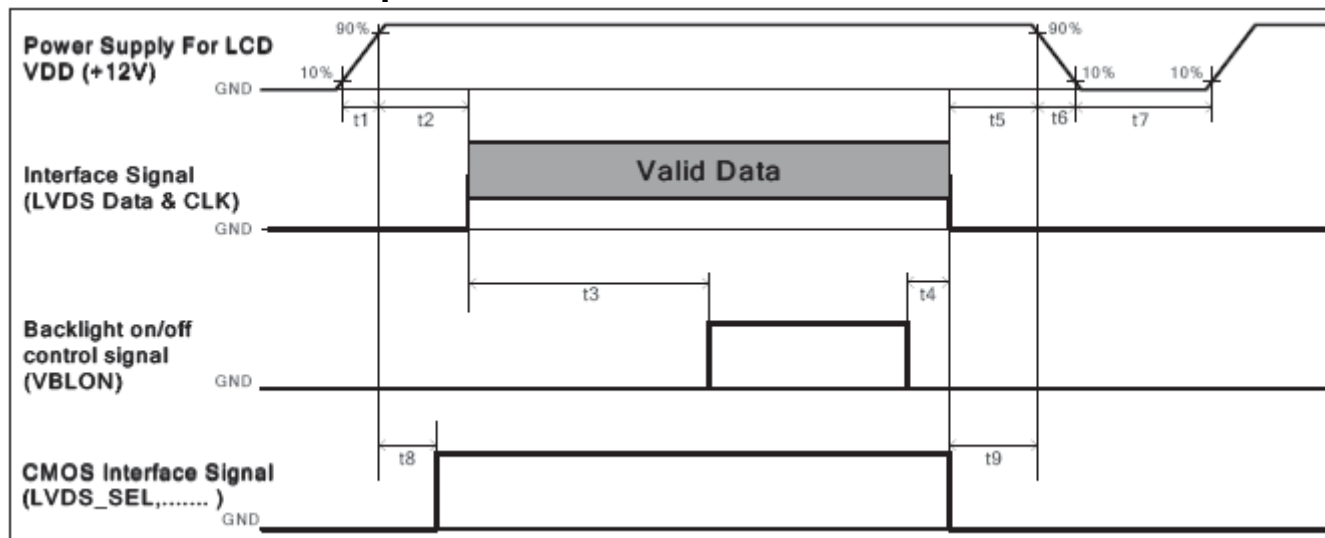

Power ON/OFF sequence timing

Parameter	Value			Units
	Min.	Typ.	Max.	
t 1	0.4	--	30	[ms]
t 2	0.1	--	50	[ms]
t 3	450	--	--	[ms]
t 4	0 (*1)	--	--	[ms]
t 5	0	--	--	[ms]
t 6	--	--	-- (*2)	[ms]
T 7	500	--	--	[ms]
t 8	10 (*3)	--	50	[ms]
t 9	0	--	--	[ms]

Note:

- (1) t4=0: concern for residual pattern before BLU turn off.
- (2) t6 : voltage of VDD must decay smoothly after power-off. (customer system decide this value)
- (3) When CMOS Interface signal is N.C.(no connection), opened in Transmitted end, t8 timing spec can be negligible.



Product Specification

G280HVN01.0

AU OPTRONICS CORPORATION

7. Connector & Pin Assignment

Physical interface is described as for the connector on module. These connectors are capable of accommodating the following signals and will be following components.

7.1 TFT LCD Module: LVDS Connector

Connector Name / Designation	Interface Connector / Interface card
Manufacturer	JAE or compatible
Type Part Number	FI-RE51S-HFor equivalent.
Mating Housing Part Number	Compatible one

Note: Regarding to pins defintions, please refer section 6.2.



Product Specification

G280HVN01.0

AU OPTRONICS CORPORATION

7.2 Backlight Unit: LED Connector

Connector Name / Designation	LED Connector
Manufacturer	CviLux
Connector Model Number	CI0114M1HR0-LF
Mating Model Number	Compatible one

PIN #	SIGNAL NAME	DESCRIPTION
1	VBL	+ 24 V
2	VBL	+ 24 V
3	VBL	+ 24 V
4	VBL	+ 24 V
5	VBL	+ 24 V
6	GND	Ground
7	GND	Ground
8	GND	Ground
9	GND	Ground
10	GND	Ground
11	NC	No Connection
12	BLON	BL on/ off
13	NC	No Connection
14	EPWM	External PWM Control



Product Specification

G280HVN01.0

AU OPTRONICS CORPORATION

8. Reliability Test

Environment test conditions are listed as following table.

	Items	Required Condition	Q'ty
1	High Temperature Storage	Ta= 60°C , 300hours	3 pcs
2	Low Temperature Storage	Ta= -20°C , 300hours	3 pcs
3	High Temperature Operation	Ta= 50°C , 300hours	3 pcs
4	Low Temperature Operation	Ta= 0°C , 300hours	3 pcs
5	Vibration Test (Non-Operating)	Wave form : random Vibration level : 1.0G RMS Bandwidth : 10 ~ 300 Hz Duration : X, Y, Z 10 min per axes X, Y, Z : Horizontal, face up	3 pcs
6	Shock Test (Non-Operating)	50G,20ms,Half-sine wave,(±X, ±Y, ±Z)	3 pcs
7	Vibration Test (with carton)	Random wave (1.05G rms, 10~ 200 Hz) Duration: X, Y, Z 10 min per axes	1 Carton
8	Drop Test (with carton)	Height : 30.5 cm (ASTMD4169-1) 1 corner, 3 edges, 6 surfaces (refer ASTMD 5276)	1 Carton



Product Specification

G280HVN01.0

AU OPTRONICS CORPORATION

9. Mechanical Characteristics

0 层: 轮廓层
 CENTER 层: 中心线
 DIM 层: 尺寸线
 HIDDEN 层: 隐藏线
 HATCH 层: 填充线
 PAH 层: 剖面线
 DASH 层: 虚线
 TEXT 层: 文字

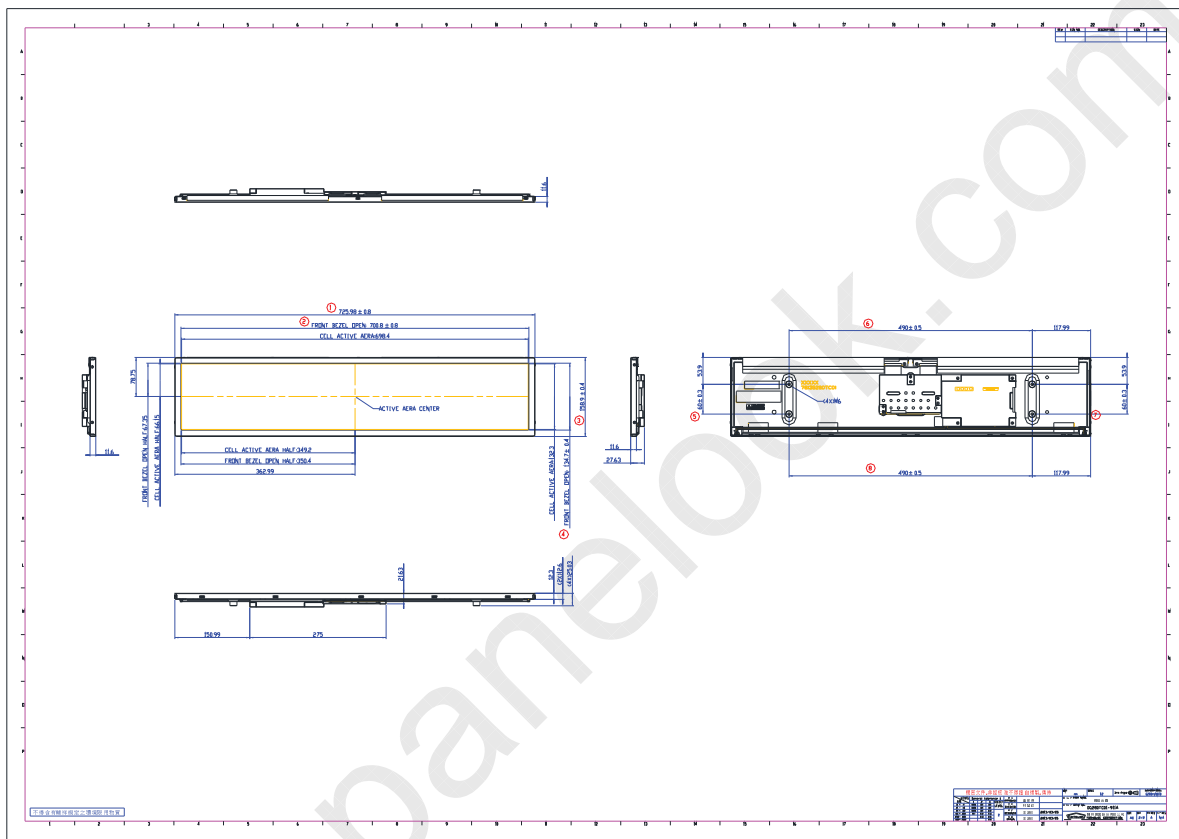



Product Specification

G280HVN01.0

AU OPTRONICS CORPORATION

10. Label and Packaging

10.1 Shipping Label (on the rear side of TFT-LCD display)

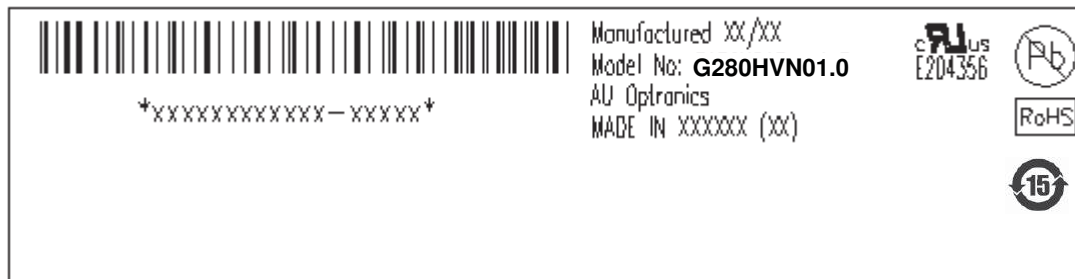

10.2 Carton Package

- The outside dimension of carton is 820 (L)mm* 376 (W)mm* 265 (H)mm, carton and cushion weight are 1,760 g.
- 7 pieces per carton box.
- 3 boxes per layer. By air, 8 layer / pallet. By sea, 8 layer / pallet. Pallet size (not include carton boxes): 1150 mm * 840 mm * 132 mm



Product Specification

G280HVN01.0

AU OPTRONICS CORPORATION

11. Safety

11.1 Sharp Edge Requirements

There will be no sharp edges or comers on the display assembly that could cause injury.

11.2 Materials

11.2.1 Toxicity

There will be no carcinogenic materials used anywhere in the display module. If toxic materials are used, they will be reviewed and approved by the responsible AUO toxicologist.

11.2.2 Flammability

All components including electrical components that do not meet the flammability grade UL94-V1 in the module will complete the flammability rating exception approval process.

The printed circuit board will be made from material rated 94-V1 or better. The actual UL flammability rating will be printed on the printed circuit board.

11.3 Capacitors

If any polarized capacitors are used in the display assembly, provisions will be made to keep them from being inserted backwards.

11.4 National Test Lab Requirement

The display module will satisfy all requirements for compliance to:

UL 60950-1, 2nd Edition, 2007-03027 (Information Technology Equipment)