

## TFT LCD Specification

**Customer:** \_\_\_\_\_

**Model Name:** ZE101IA-17B

**Date:** 2018/11/12

**Version:** 0.2

**Preliminary Specification**

**Final Specification**

**For Customer's Acceptance**

Approved by	Comment

## Table of Contents

1. FEATURES-----	4
2. GENERAL SPECIFICATIONS-----	4
3. PIN DESCRIPTION-----	5
3.1 Golden finger-----	5
3.2 PIN assignment-----	6
3.3 Advice circuit for customer system-----	8
4. ABSOLUTE MAXIMUM RATING-----	10
5. DC CHARACTERISTICS-----	11
5.1 Parameter-----	11
5.2 Current Consumption-----	11
5.3 Power Sequence-----	11
6. AC CHARACTERISTICS-----	14
6.1 Data Input Format-----	14
6.2 Parallel RGB Input Timing Table-----	14
6.3 AC Electrical Characteristic-----	15
6.4 Timing-----	16
6.5 Data Input Format-----	17
7. OPTICAL CHARACTERISTICS-----	18
7.1 Optical Specification-----	18
7.2 Basic measure condition-----	18
8. QUALITY ASSURANCE-----	20
9. HANDING CAUTIONS-----	21
9.1 ESD (Electrical Static Discharge) Strategy-----	21
9.2 Environment-----	21
9.3 Others-----	21
10. MECHANICAL DRAWING-----	22
11. PACKAGE DRAWING-----	23
11.1 Packaging Material Table-----	23
11.2 Packaging Quantity-----	23
11.3 Packaging Drawing-----	23

## RECORD OF REVISION

Version	Revise Date	Page	Description
0.1	2018/09/07	All	New
0.2	2018/11/12	P4,P5,P18	Update General Specifications, Pin Description and Optical Characteristics



## 1. FEATURES

ZE1011A-17B is a transmissive type color active matrix liquid crystal display (LCD), which uses amorphous thin film transistor (TFT) as switching devices. This panel has a 10.1 inches diagonally measured active display area with 1024 x 600 resolution. This product is composed of a TFT LCD panel, Polarizers, driver ICs and FPC.

## 2. GENERAL SPECIFICATIONS

Item	Description	Unit
Display Size	10.1	inch
Display Type	Transmissive, a-Si	-
Active Area (HxV)	222.72 (H) x 125.28 (V)	mm
Number of Dots (HxV)	1024 x RGB x 600	dot
Pixel Pitch(HxV)	0.2175 x 0.2088	mm
Color Arrangement	RGB Stripe	-
Color Numbers	16.7 M	-
Outline Dimension (HxVxD)	229.66 (H) x 133.88 (V) x 1.27 (D)	mm
NTSC (CIE1931) (Under C light)	50(Typ.)	%
White Point (x,y) (Under C light)	x:0.317,y: 0.326(Typ.)	
Response Time	≤35	ms
Viewing Angle (Light On) (R/U/L/D)	CR ≥ 10 @ R/L/U/D(80°/80°/80°/80°) (Typ.)	
Surface Treatment	HC	
Contrast Ratio (Light On)	800:1 (Typ)	
Operation Temperature	-20~70	°C
Storage Temperature	-30~80	°C
Interface	LVDS	
Weight	85.4	G

### 3. Pin Description

#### 3.1 Golden finger

PIN pitch = 0.5mm

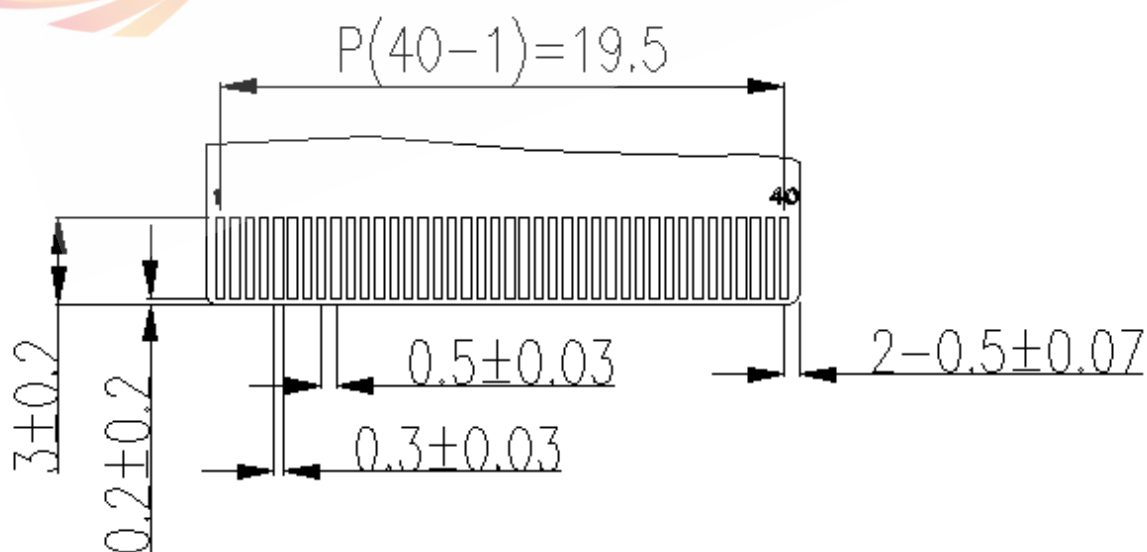
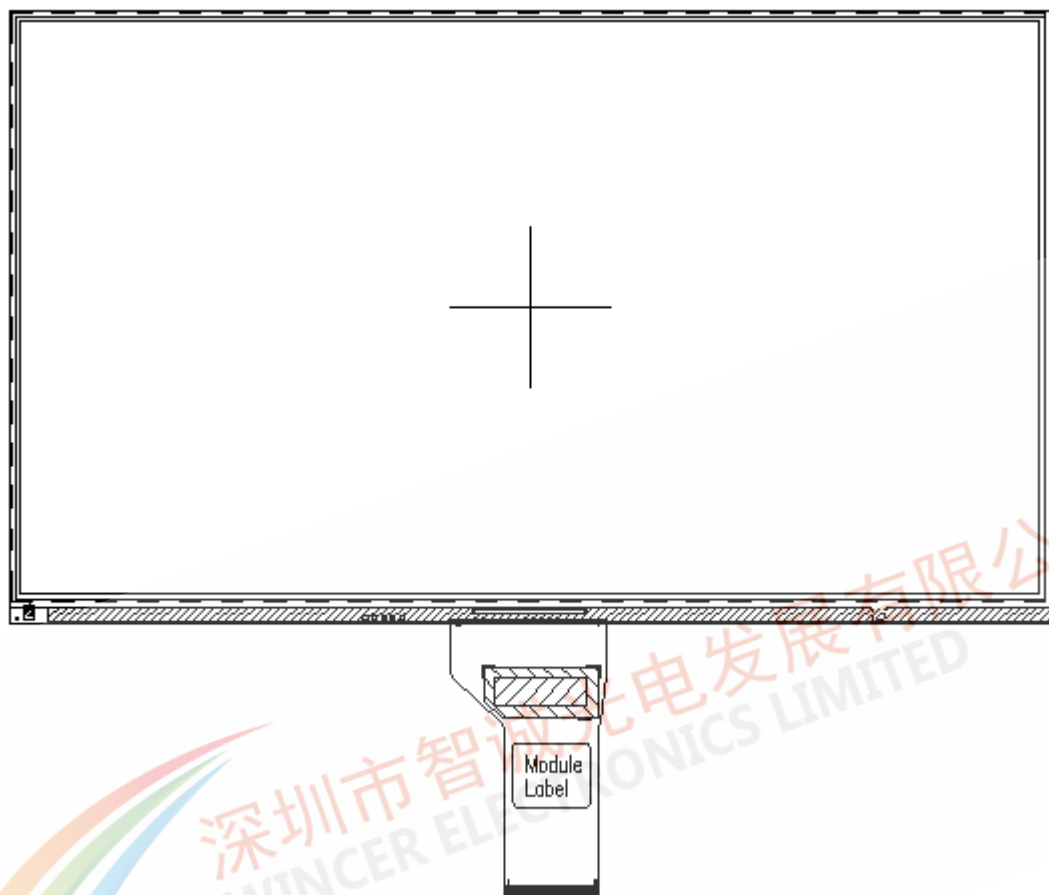

#### 3.2 PIN Assignment

No	Symbol	I/O	Function	Remark
1	VCOM	P	Common Voltage	

2	VDD	P	Power Voltage for digital circuit	
3	VDD	P	Power Voltage for digital circuit	
4	NC	-	No connection	
5	RESET	I	Global reset pin	
6	STBYB	I	Standby mode, Normally pulled high STBYB = "1", normal operation STBYB = "0", timing controller, source driver will turn off, all output are High-Z	
7	GND	P	Ground	
8	RXIN0-	I	LVDS differential data input 0-	
9	RXIN0+	I	LVDS differential data input 0+	
10	GND	P	Ground	
11	RXIN1-	I	LVDS differential data input 1-	
12	RXIN1+	I	LVDS differential data input 1+	
13	GND	P	Ground	
14	RXIN2-	I	LVDS differential data input 2-	
15	RXIN2+	I	LVDS differential data input 2+	
16	GND	P	Ground	
17	RXCLKIN-	I	LVDS differential clock input -	
18	RXCLKIN+	I	LVDS differential clock input +	
19	GND	P	Ground	
20	RXIN3-	I	LVDS differential data input 3-	
21	RXIN3+	I	LVDS differential data input 3+	
22	GND	P	Ground	
23	NC	-	No connection	
24	NC	-	No connection	
25	GND	P	Ground	
26	NC	-	No connection	
27	PWMO	O	Backlight CABC controller signal output	
28	SELB	I	6bit/8bit mode select	Note 1
29	AVDD	P	Power for Analog Circuit	
30	GND	P	Ground	
31	LED-	P	LED Cathode	
32	LED-	P	LED Cathode	
33	L/R	I	Horizontal inversion	Note 3
34	U/D	I	Vertical inversion	Note 3
35	VGL	P	Gate OFF Voltage	
36	CABCEN1	I	CABC H/W enable	Note 2

37	CABCEN0	I	CABC H/W enable	Note 2
38	VGH	P	Gate ON Voltage	
39	LED+	P	LED Anode	
40	LED+	P	LED Anode	

I: input, O: output, P: power

Note1: If LVDS input data is 6 bits, SELB must be set to High;

If LVDS input data is 8 bits, SELB must be set to Low.

Note2: When CABC\_EN="00", CABC OFF.

When CABC\_EN="01", user interface image.

When CABC\_EN="10", still picture.

When CABC\_EN="11", moving image.

When CABC off, don't connect DIMO, else connect it to backlight.

Note 3: Selection of scanning mode

Setting of scan control input		Scanning direction
U/D	L/R	
GND	VDD	Up to down, left to right
VDD	GND	Down to up, right to left
GND	GND	Up to down, right to left
VDD	VDD	Down to up, left to right

Definition of scanning direction .Refer to the figure as below

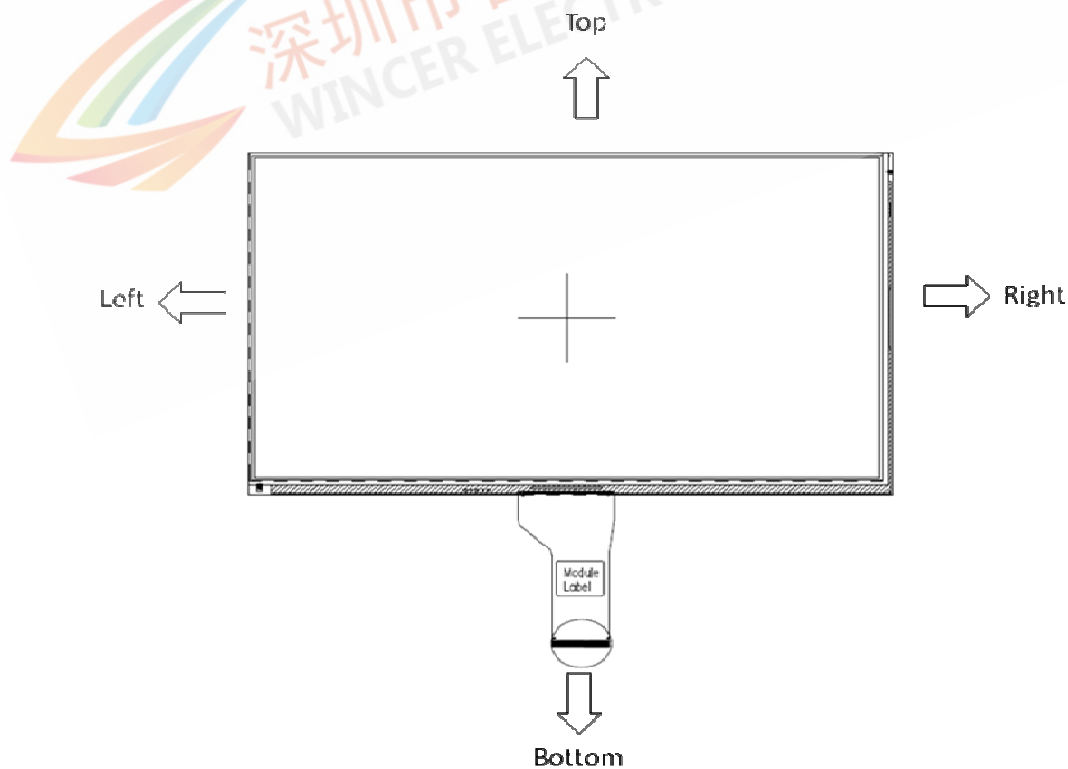

### 3.3 Advice circuit for customer system

#### 3.3.1 Power PIN: AVDD/VDD/VGH/VGL

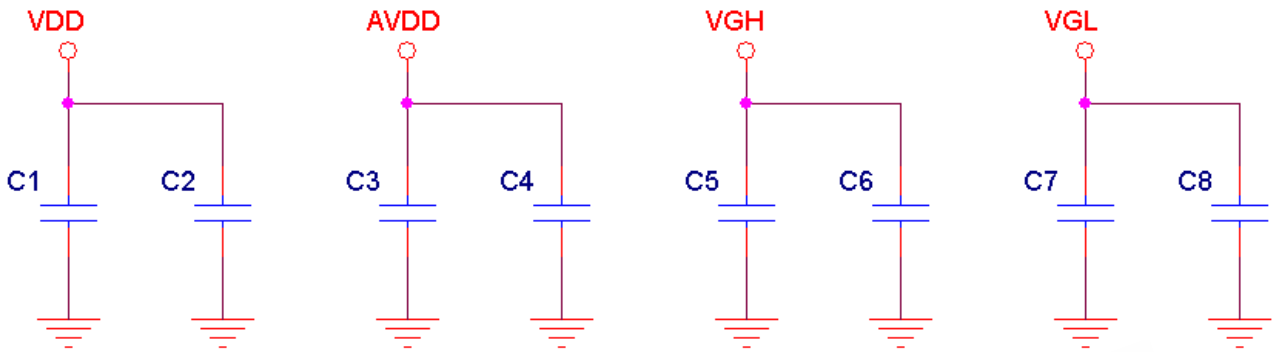

#### 3.3.2 Control PIN: RESET

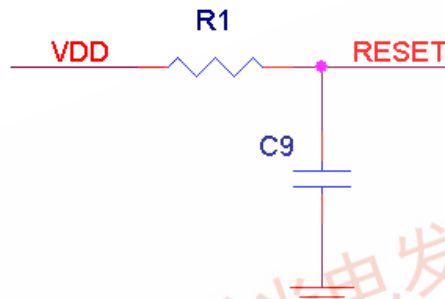

#### 3.3.3 VCOM

Typical VCOM is only a reference value, it must be optimized according to each LCM. Be sure to use VR;

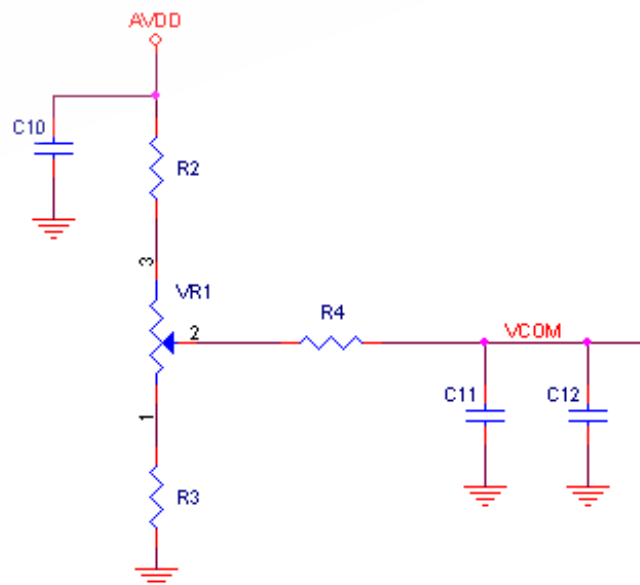



### 3.3.4 LVDS signal: LVDS terminal resistor

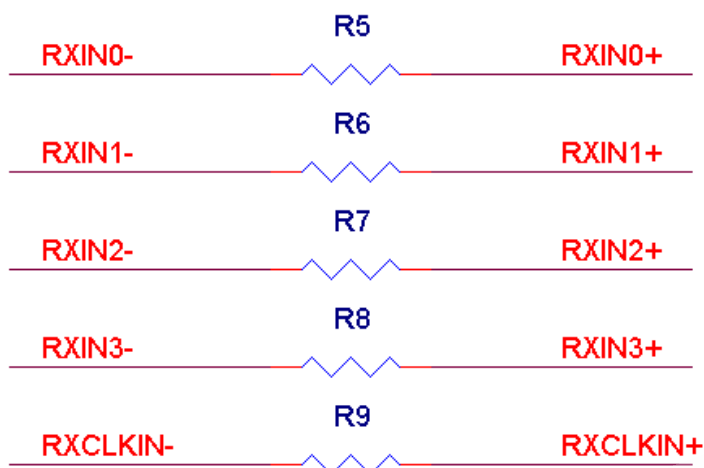

### 3.3.5 Suggestion BOM

Location	Description
C1,C11	10uF,X5R,10V
C2,C12	100nF,X5R,10V
C3,C7	10uF,X5R,25V
C4,C8	100nF,X5R,25V
C5	10uF,X5R,50V
C6	100nF,X5R,50V
C9	1uF,X5R,10V
C10	1uF,X5R,25V
R1	10Kohm,1%
R2	12Kohm,1%
R3	10Kohm,1%
R4	0ohm,1%
VR1	10Kohm,1%
R5,R6,R7,R8,R9	100ohm,1%

#### 4. ABSOLUTE MAXIMUM RATING

Item	Symbol	Min.	Max.	Unit	Remark
Power Supply Voltage	VDD	-0.3	3.6	V	
	AVDD	-0.3	15	V	
	VGH	-0.3	30	V	
	VGL	-15	0.3	V	
Storage temperature	Tstg	-30	+80	°C	
Operating Temperature	Topr	-20	+70	°C	

Note:

- (1) All of the voltages listed above are with respect to GND= 0V
- (2) Device is subject to be damaged permanently if stresses beyond those absolute maximum ratings listed above.

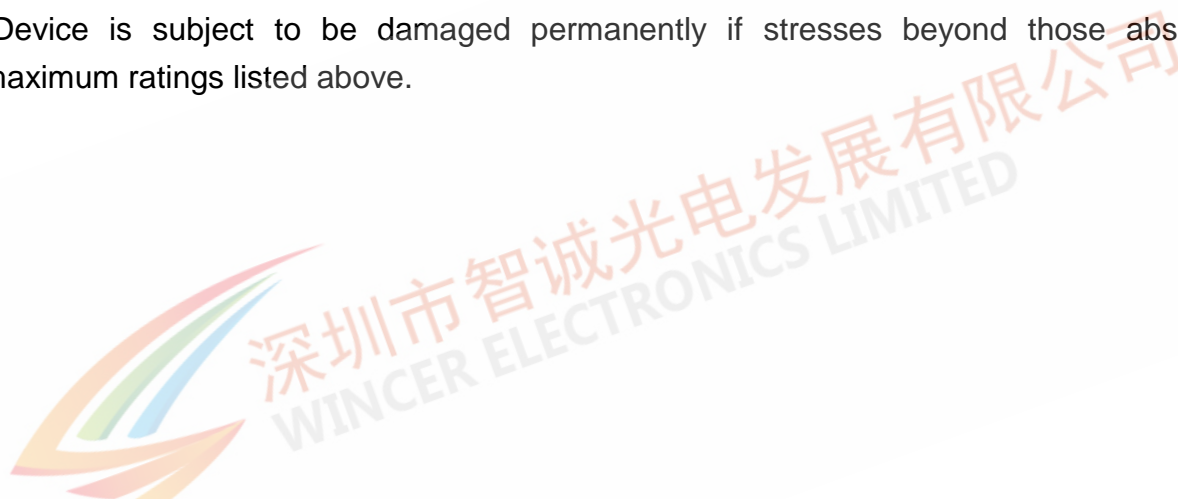

## 5. DC CHARACTERISTICS

### 5.1 Parameter

Item	Symbol	Value			Units	Remark
		Min	Typ	Max		
Power supply voltage	VDD	3.0	3.3	3.6	V	
	AVDD	12	12.2	12.4	V	
	VGH	20	22	24	V	
	VGL	-11	-10	-9	V	
Input signal voltage	VCOM	4.39	5.39	6.39	V	
Logic high level input voltage	VIH	0.7xVDD	-	VDD	V	Note 1
Logic low level input voltage	VIL	VSS	-	0.3xVDD	V	

(Ta = 25 ± 2°C)

Note 1: Including signal: U/D、L/R、RESET、STBYB、SELB、CABCEN0、CABCEN1.

### 5.2 Current Consumption

Item	Symbol	Value			Units	Remark
		Min	Typ	Max		
Current for Driver	IVDD	10	15	20	mA	VDD=3.3V
	IAVDD	8	45	65	mA	AVDD=12.2V
	IVGH	0.1	0.6	2	mA	VGH=22V
	IVGL	0.1	0.6	2	mA	VGL=-10V

### 5.3 Power Sequence

#### Power on

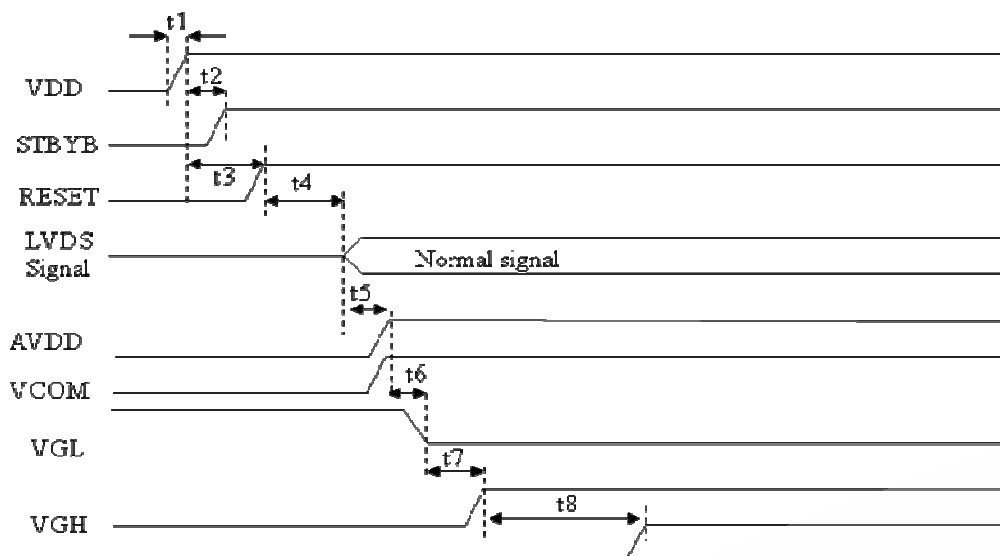

Symbol	SPEC			Unit
	Min.	Typ.	Max.	
t1	1	10	20	ms
t2	20	35	50	us
t3	1	10(RC Delay)	12	ms
t4	30	50	100	ms
t5	0.1	5	20	ms
t6	20	70	120	ms
t7	40	90	140	ms
t8	150	170	200	ms

**Power off**

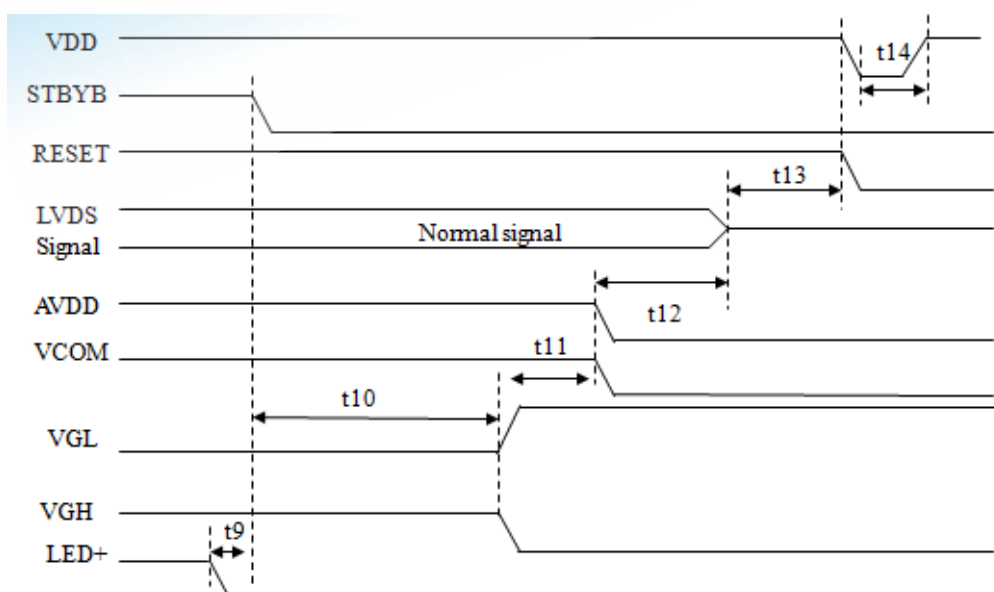

Symbol	SPEC			Unit
	Min.	Typ.	Max.	
t9	0.1	1	10	ms
t10	120	150	200	ms
t11	50	100	200	ms
t12	1	10	20	ms
t13	0.1	10	100	ms
t14	500	-	-	ms



## 6. Timing Characteristics

### 6.1 AC Electrical Characteristics

Parameter	Symbol	Min	Typ	Max	Units	Condition
Clock frequency	RxFCLK	26.2	51.2	71	MHz	
Input data skew margin	TRSKM	500	500	$1/(2 \cdot RxFCLK)$	ps	Typical value for 1024*600 resolution
Clock high time	TLVCH		$4/(7 \cdot RxFCLK)$		ns	$ VID =400\text{mv}$ $RxVCM=1.2\text{V}$ $RxFCLK=71\text{MHz}$ $VDD\_LVDS=3.3\text{V}$
Clock low time	TLVCL		$3/(7 \cdot RxFCLK)$		ns	
VSD setup time	TenPLL		$0 < TenPLL < 150$		us	

### 6.2 Input Clock and Data Timing Diagram

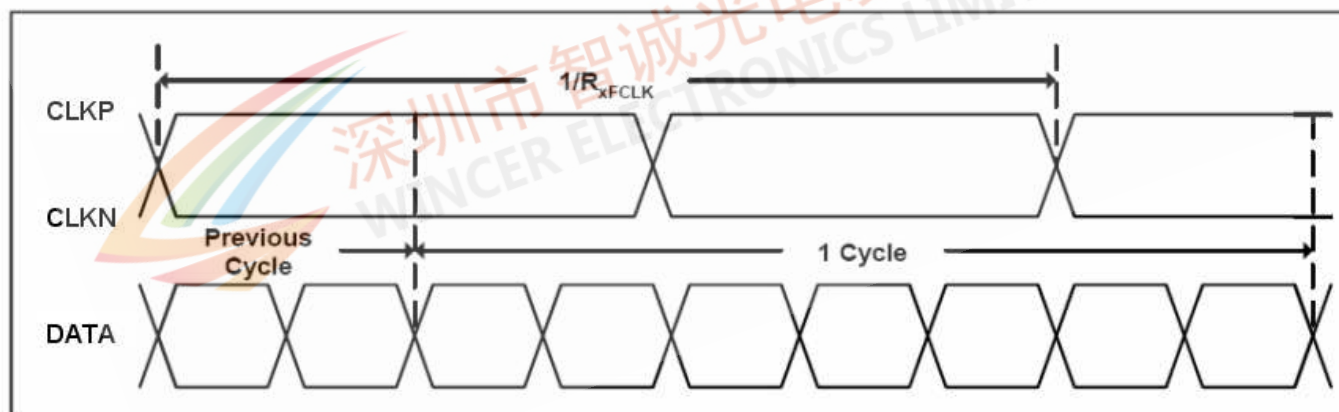

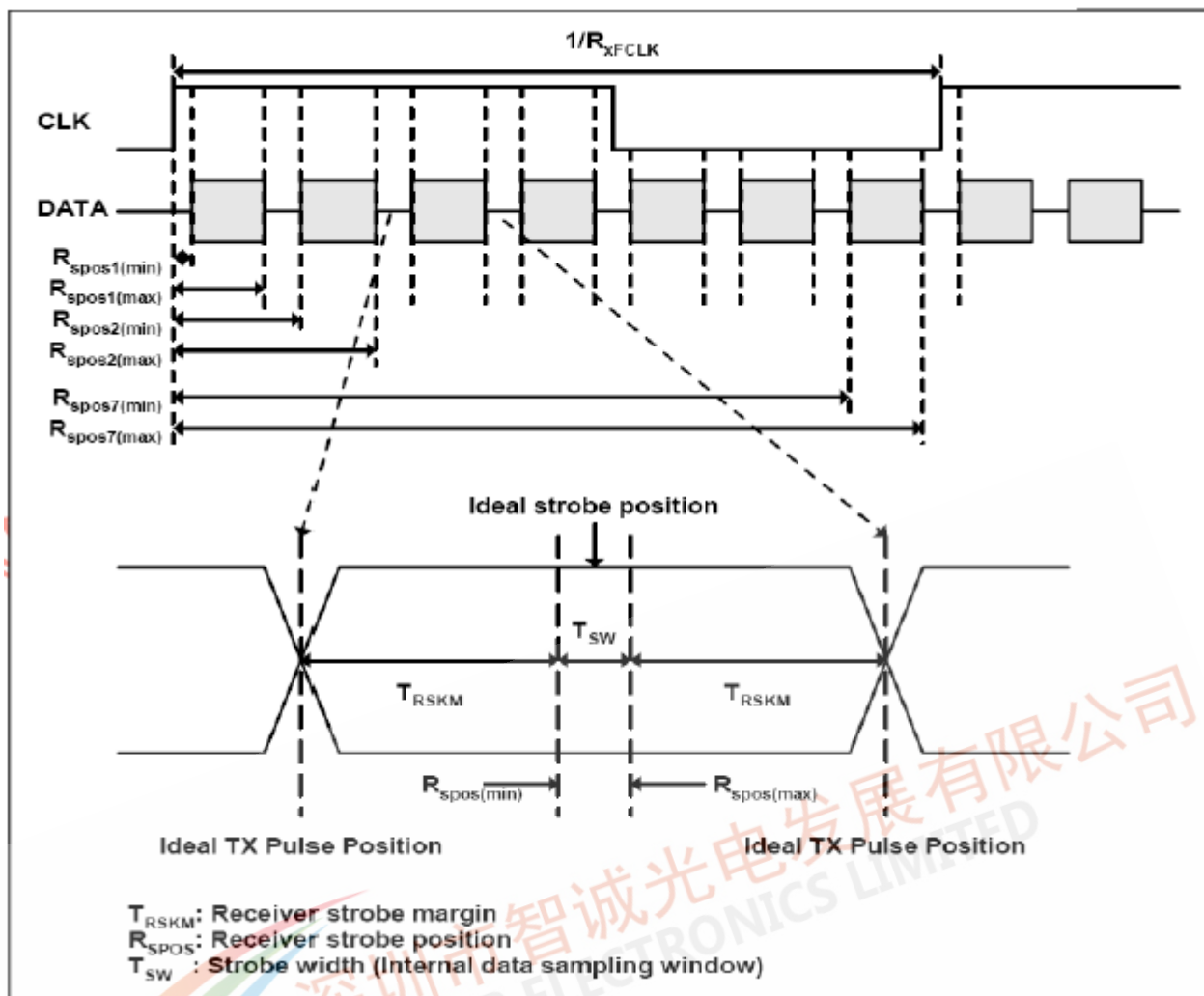

### 6.3 Electrical Characteristics

Parameter	Symbol	Min	Typ	Max	Units	Condition
Differential input high threshold voltage	RxVTH	0.1	0.2	VID	V	RxVCM=1.2V
Differential input low threshold voltage	RxVTL	- VID	-0.2	-0.1	V	
Input voltage range (singled-end)	RxVIN	0	1.2±0.4	2.4	V	
Differential input common mode voltage	RxVCM	VID /2	1.2	2.1- VID /2	V	
Differential input voltage	VID	0.2	0.4	0.6	V	
Differential input leakage current	RVxliz	-10	0	+10	uA	

LVDS Digital Operating Current	Iddlvs	8	22	30	mA	Fclk=65MHz, VDD=3.3V
LVDS Digital Standby Current	Istlvs	0	200	300	uA	Clock & all Functions are stopped
LVDS Differential impedance	Zdiff	90	100	110	ohm	RXINx+/-, RXINCLK+/-

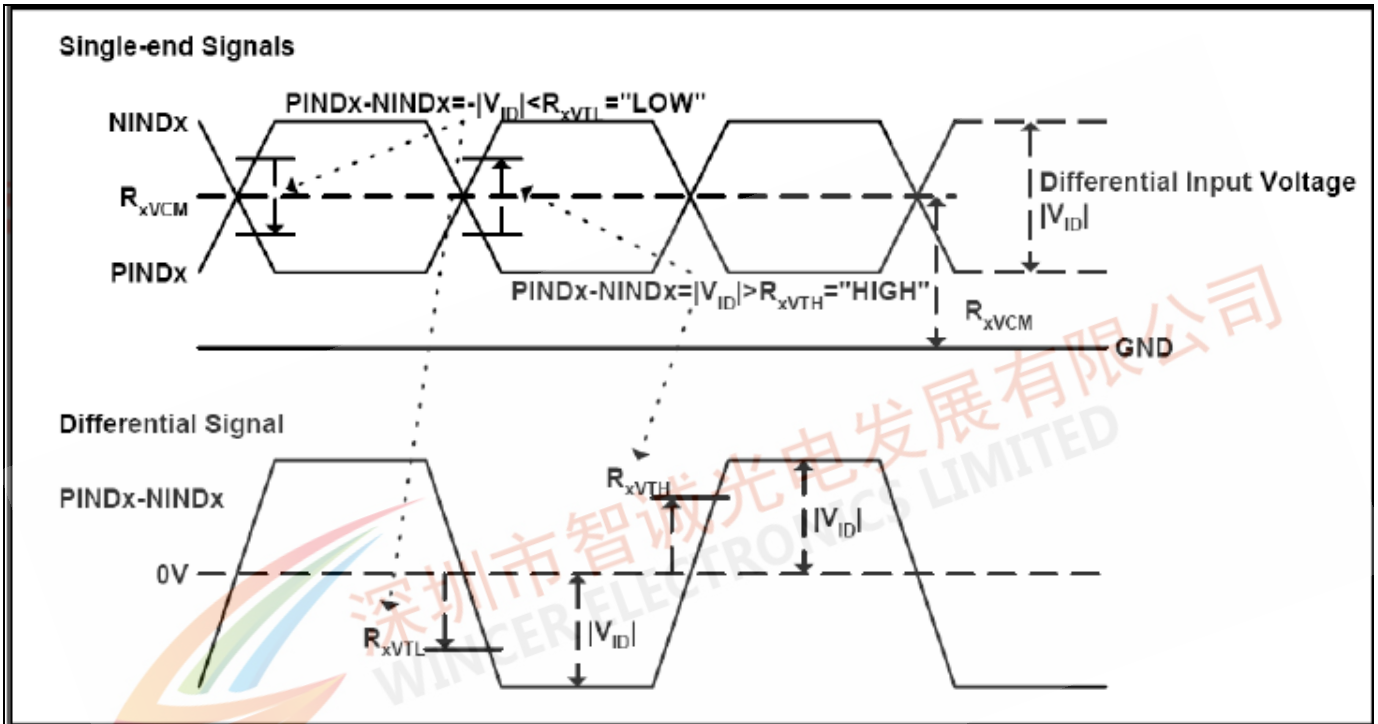

## 6.4 Timing

Parallel	Symbol	Vaule			Unit
		Min	Typ	Max	
DCLK Freqency Frame rate=60Hz	fclk	42.5	51.2	67.2	MHz
Horizontal display area	thd	1024			DCLK
HSYNC period time	thpw	1164	1344	1400	DCLK
HSYNC blanking	thb+thfp	140	320	376	DCLK
Vertical display area	tvd	600			H
VSYNC period time	tvpw	610	635	800	H
VSYNC blanking	tvb+tvfp	10	35	200	H



### 6.5 Data Input Format

#### 6bit LVDS input

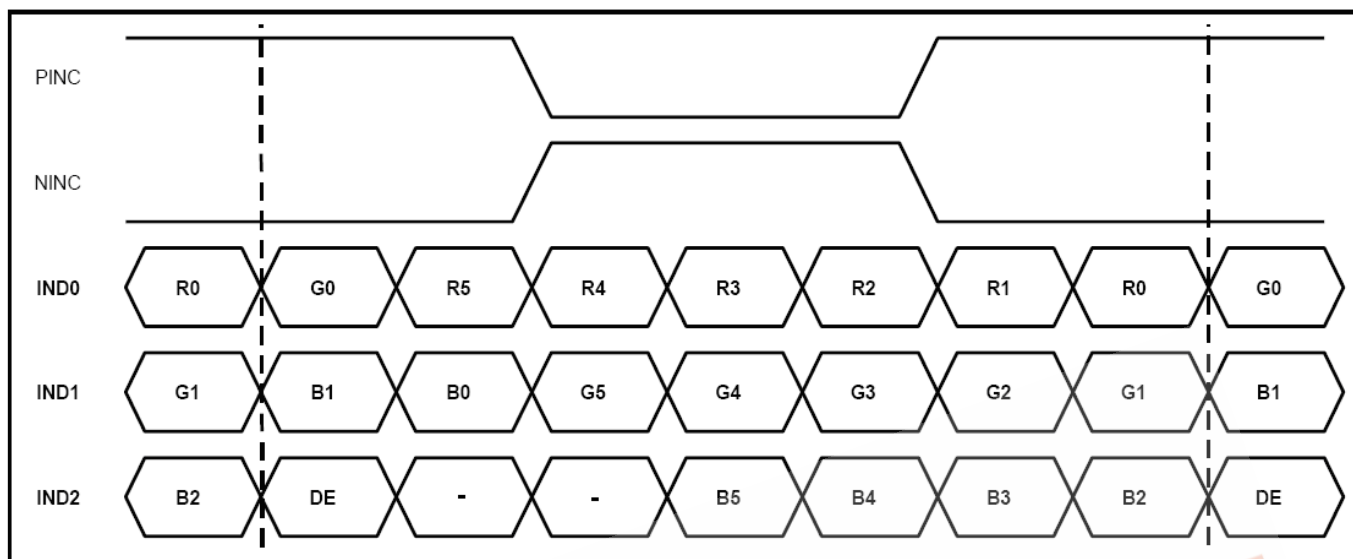

#### 8bit LVDS input

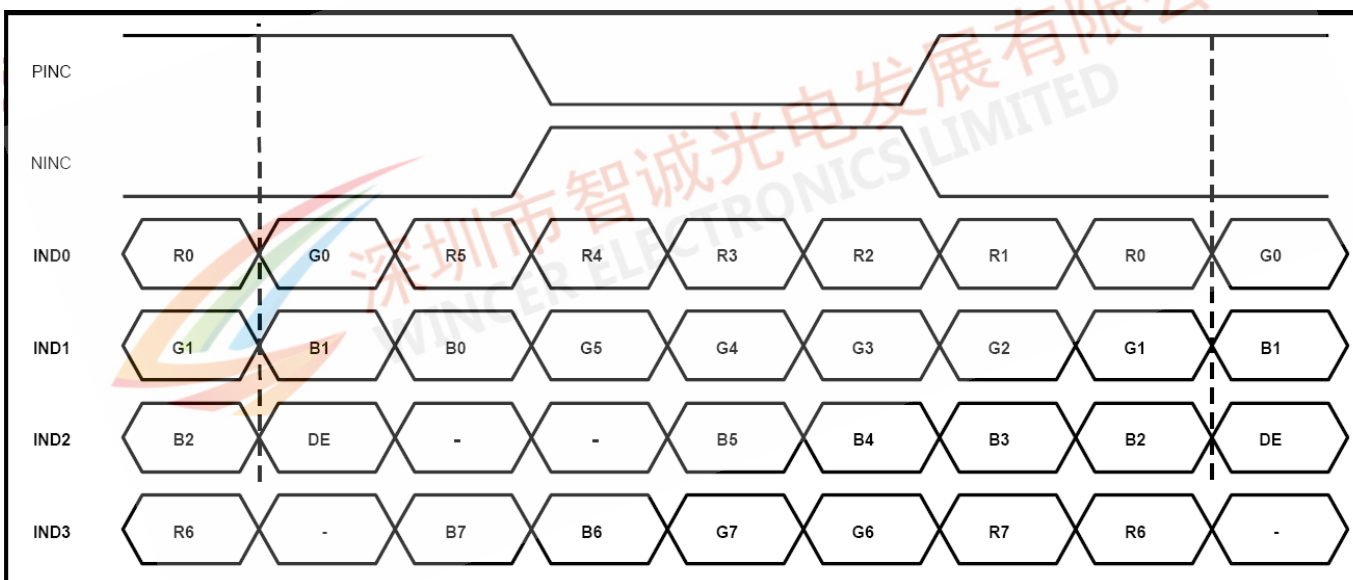

## 7. OPTICAL CHARACTERISTICS

### 7.1 Optical Specification

 $T_a=25^{\circ}\text{C}$ 

Item	Symbol	Condition	MIN	TYP	MAX	Unit	Remarks	
Viewing Angles	$\Theta_{11}(\text{R})$	$\text{CR} \geq 10$	75	80	-	Degree	Note 7-1	
	$\Theta_{12}(\text{L})$		75	80	-			
	$\Theta_{21}(\text{U})$		75	80	-			
	$\Theta_{22}(\text{D})$		75	80	-			
Response Time	$\text{Tr}+\text{Tf}$	$\Theta=0^{\circ}$	-	25	35	ms	Note 7-2	
Transmittance	T		4.97	5.54	-	%	Note 7-3	
Contrast Ratio	CR		600	800	-	-	Note 7-4	
Chromaticity	White		x	0.257	0.317	0.347		Note 7-5
			y	0.296	0.326	0.356		
NTSC	-		45	50	-	%		

### 7.2 Basic measure condition

(1) Driving voltage

Based on item 5. DC CHARACTERISTICS and 6. AC CHARACTERISTICS

(2) Ambient temperature:  $T_a=25^{\circ}\text{C}$

(3) Testing point: measure in the display center point and the test angle  $\Theta=0^{\circ}$

(4) Testing Facility: Environmental illumination:  $\leq 1$  Lux

Note 7-1: Viewing angle diagrams

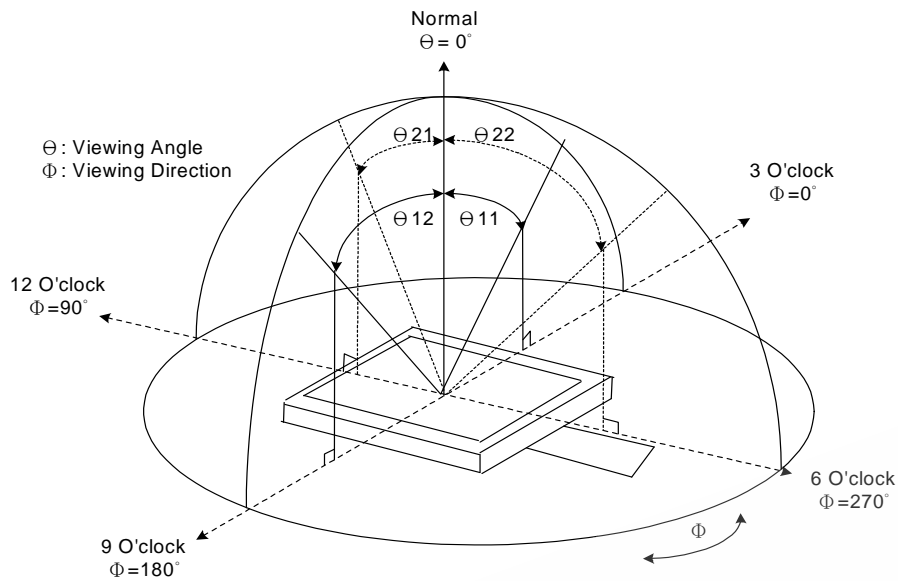

Note 7-2: Response time

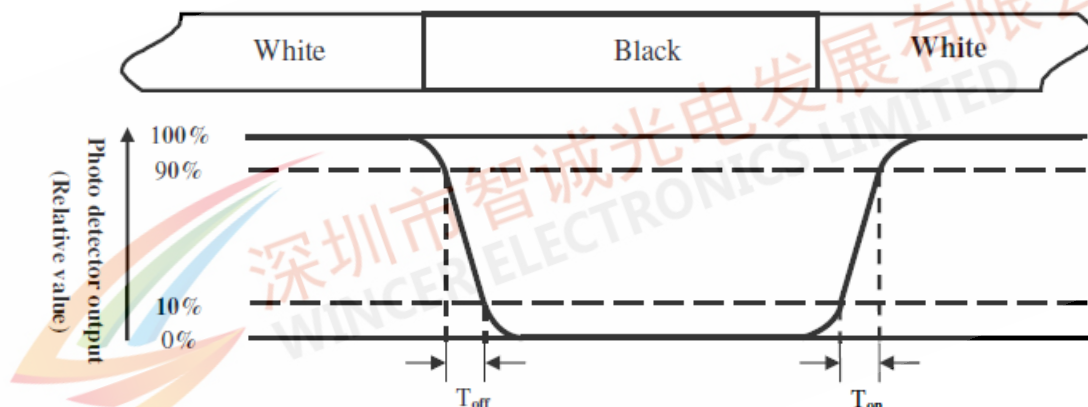

Note 7-3: Transmittance

The transmittance is measured on INX stabilized backlight.

Note 7-4: Contrast ratio

The contrast ratio can be calculated by the following expression.

$$\text{Contrast Ratio (CR)} = \text{White} / \text{Black}$$

Note 7-5 Chromaticity

The chromaticity is measured in CIE 1931 at the center point of C Light Source.

**8. QUALITY ASSURANCE**

No.	Test Items	Test Condition	Note
1	High Temperature Storage	80°C, 240hrs	Note 1, 2
2	Low Temperature Storage	-30°C, 240hrs	Note 1, 2
3	High Temperature Operation	70°C, 240hrs	Note 1, 2
4	Low Temperature Operation	-20°C, 240hrs	Note 1, 2
5	High Temperature and High Humidity Storage	60°C, 90%RH, 240hrs	Note 1, 2
6	Thermal Shock	-30°C/0.5h ~ +80°C/0.5h for a total 100 cycles	Note 1, 2
7	Electro Static Discharge	C=150pF,R=330Ω, 5point/panel Air:±4Kv, 5times	Note 2
8	Package Drop Test	Height:60cm,1 corner,3 edges,6 surfaces	Note 2

Note 1: The test samples have recovery time for 2 hours at room temperature before the function check. In the standard conditions, there is no display function NG issue occurred.

Note 2: After the reliability test, the product only guarantees operation, but don't guarantee all of the cosmetic specification.

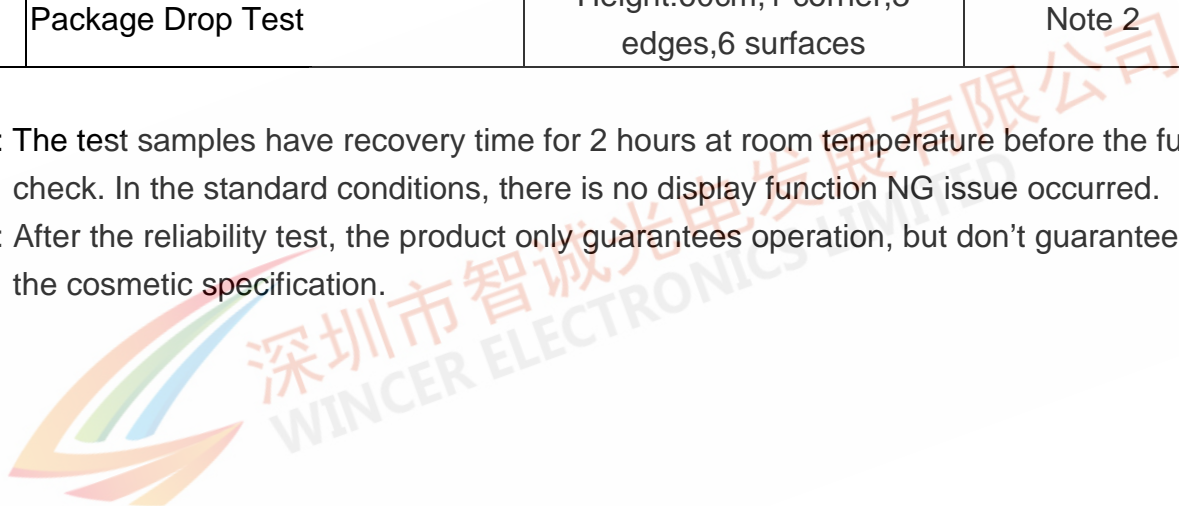

## 9. HANDING CAUTIONS

### 9.1 ESD (Electrical Static Discharge) strategy

ESD will cause serious damage of the panel, ESD strategy is very important in handling. Following items are the recommended ESD strategy

- (1) In handling LCD panel, please wear gloves with non-charged material. Using the conduction ring connects wrist to the earth and the conducting shoes to the earth necessary is.
- (2) The machine and working table for the panel should have ESD protection strategy.
- (3) In handling the panel, ionized airflow decreases the charge in the environment is necessary.
- (4) In the process of assemble module, shield case should connect to the ground.

### 9.2 Environment

- (1) Working environment of the panel should be in the clean room.
- (2) Because touch panel has protective film on the surface, please remove the protection film slowly with ionized air to prevent the electrostatic discharge.

### 9.3 Others

- (1) Turn off the power supply before connecting and disconnecting signal input cable.
- (2) Because the connection area of FPC and panel is not so strong, do not handle panel only by FPC or bend FPC.
- (3) Water drop on the surface or condensation as panel power on will corrode panel electrode.
- (4) As the packing bag open, watch out the environment of the panel storage. High temperature and high humidity environment is prohibited.
- (5) In the case the TFT LCD module is broken, please watch out whether liquid crystal leaks out or not. If your hand touches liquid crystal, wash your hands cleanly with water and soap as soon as possible.

## 10. MECHANICAL DRAWING

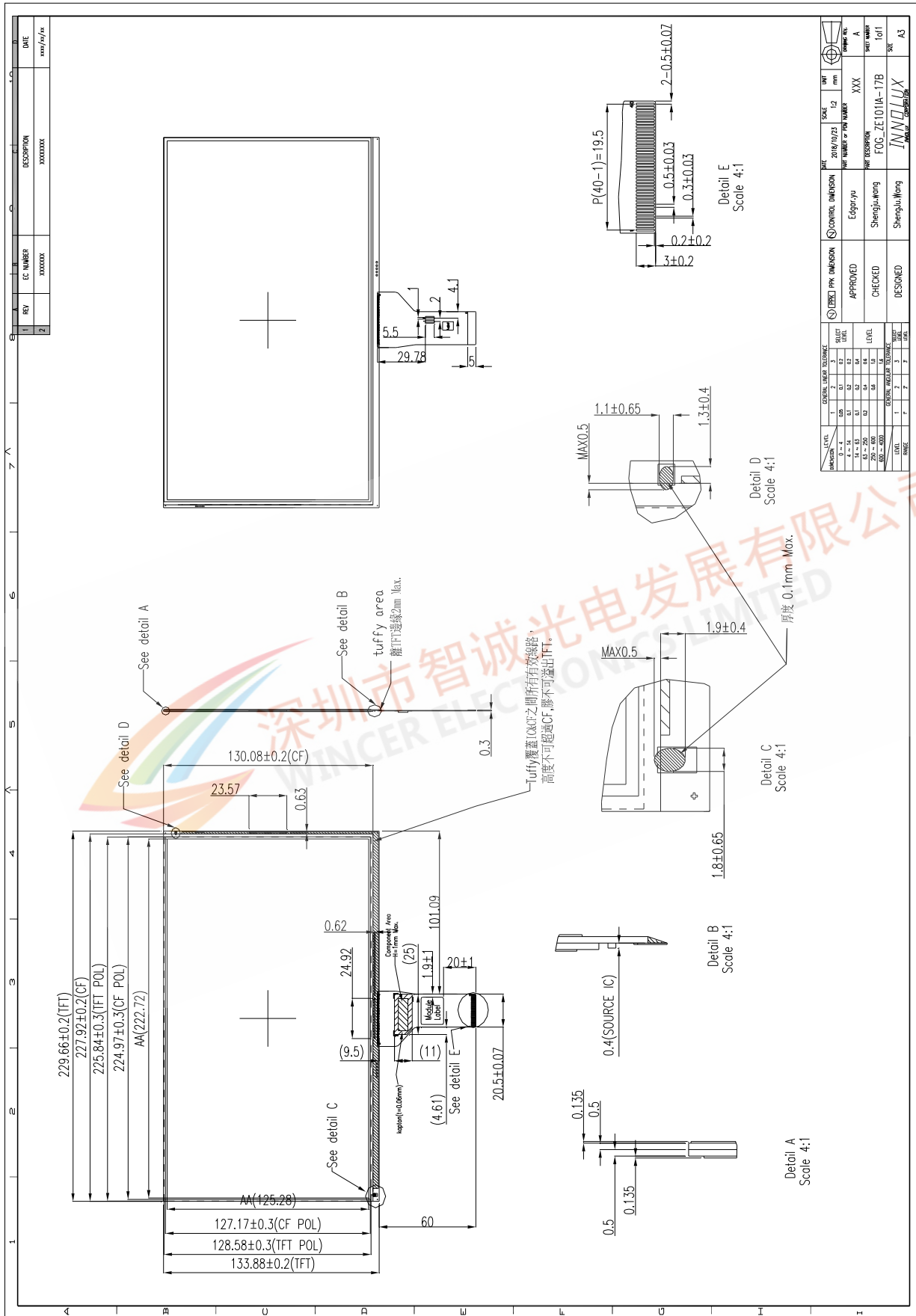



## 11. Packaging Drawing

### 11.1. Packaging Material Table

No	Item	Model (Material)	Dimensions(mm)	Unit Weight (Kg)	Quantity (pcs)	Remark	
1	FOG Panel	ZE101IA-17B	229.66*133.88*1.27	0.0854	36		
2	Dust-Proof Bag	LDPE	700 x 530x0.05	0.0595	1		
3	Tray	PET	472x310x15.4	0.196	19		
4	Spacer	EPE	290x227x3.2	0.0054	36		
5	Cushion	EPE	518x356x90	0.145	2		
6	Drier	Montmorillonite, gray	100 x 75	0.035	2		
7	Carton	Corrugated paper	530x367x260	0.95	1		
8	Total weight	8.34 (g)					

### 11.2. Packaging Quantity

Total Panel quantity of per Carton: 2 pcs/ tray x18(19-1) tray / Carton = 36pcs

### 11.3. Packaging Drawing

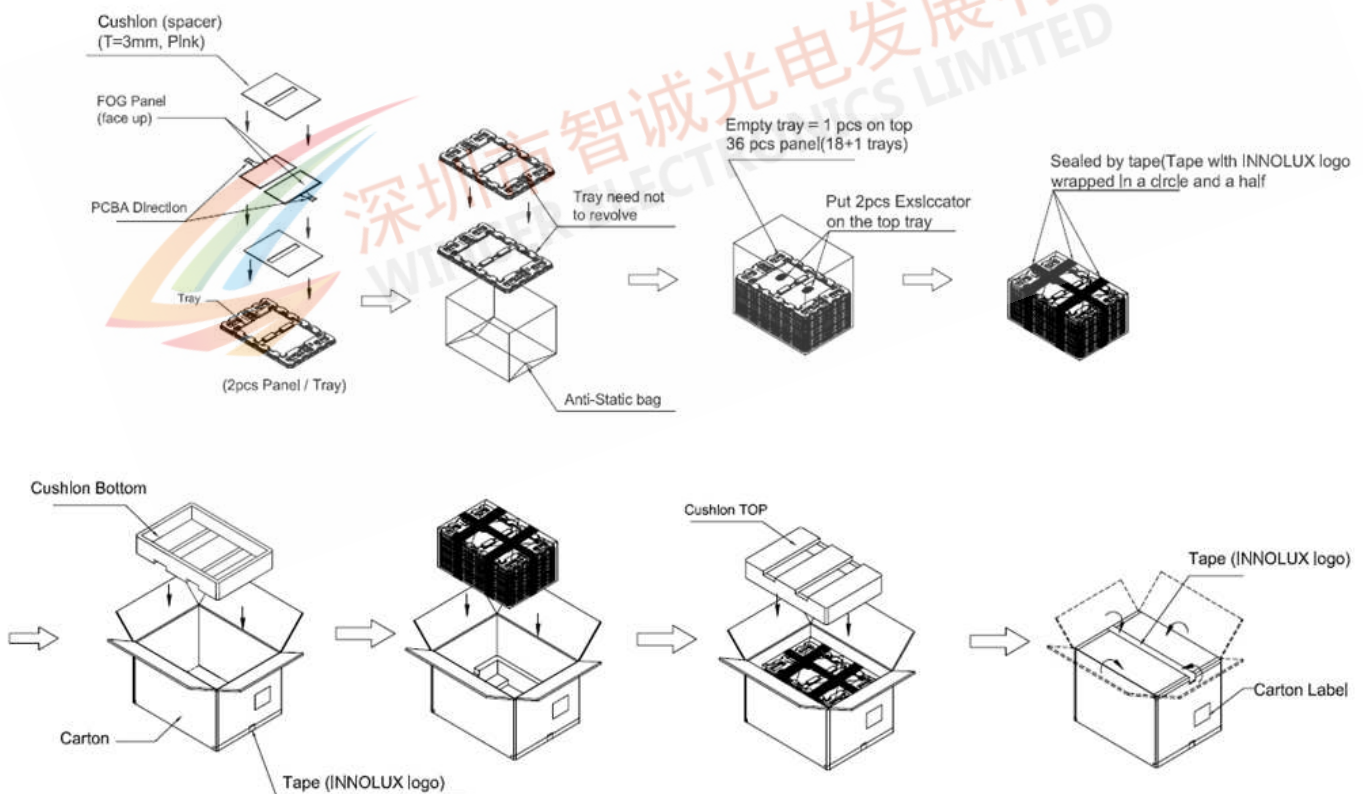

(1) Carton Dimensions : 530(L)\*367(W)\*260(H)

(2) 36 Panels /Carton