

Doc. Number:

- Tentative Specification
- Preliminary Specification
- Approval Specification

MODEL NO.: DJ070NA
SUFFIX: 03J

Customer:

APPROVED BY SIGNATURE

Name / Title

Note :

Only for reference

Please return 1 copy for your confirmation with your signature and comments.

Approved By	Checked By	Prepared By
		Steve

REVISION HISTORY

Version	Date	Page	Description
0.0	Jan,25,2015	All	Spec Ver.0.0 was first issued.
0.1	Feb,03,2015	Page 1 Page 5 Page 19	Page 1 : Add backlight power consumption specification. Page 1 : Add bezel opening specification Page 5 : Modify the operation temperature and storage temperature specification Page 19 : Modify the product drawing (Add detail pin definition)



深圳市智誠光電發展有限公司
WINCER ELECTRONICS LIMITED

Contents

1	General Specifications.....	1
2	Pin assignment.....	2
3	Operation Specifications.....	5
3.1	Absolute Maximum Rating.....	5
3.1.1	Typical Operation Conditions.....	6
3.1.2	Current Consumption.....	7
3.1.3	Backlight Driving Conditions.....	7
3.2	Power Sequence.....	8
3.3	Timing Characteristics.....	9
3.3.1	AC Electrical Characteristics.....	9
3.3.2	Data Input Format.....	10
3.3.3	Timing.....	10
3.3.4	Data input format.....	11
4	Optical Specifications.....	13
5	Reliability Test Items.....	17
6	General Precautions.....	18
6.1	Safety.....	18
6.2	Handling.....	18
6.3	Static Electricity.....	18
6.4	Storage.....	18
6.5	Cleaning.....	18
7	Mechanical Drawing.....	19
8	Package Drawing.....	20
8.1	Package Material Table.....	20
8.2	Packaging Quantity.....	20
8.3	Packaging Drawing.....	21
8.4	Shipping Drawing.....	22

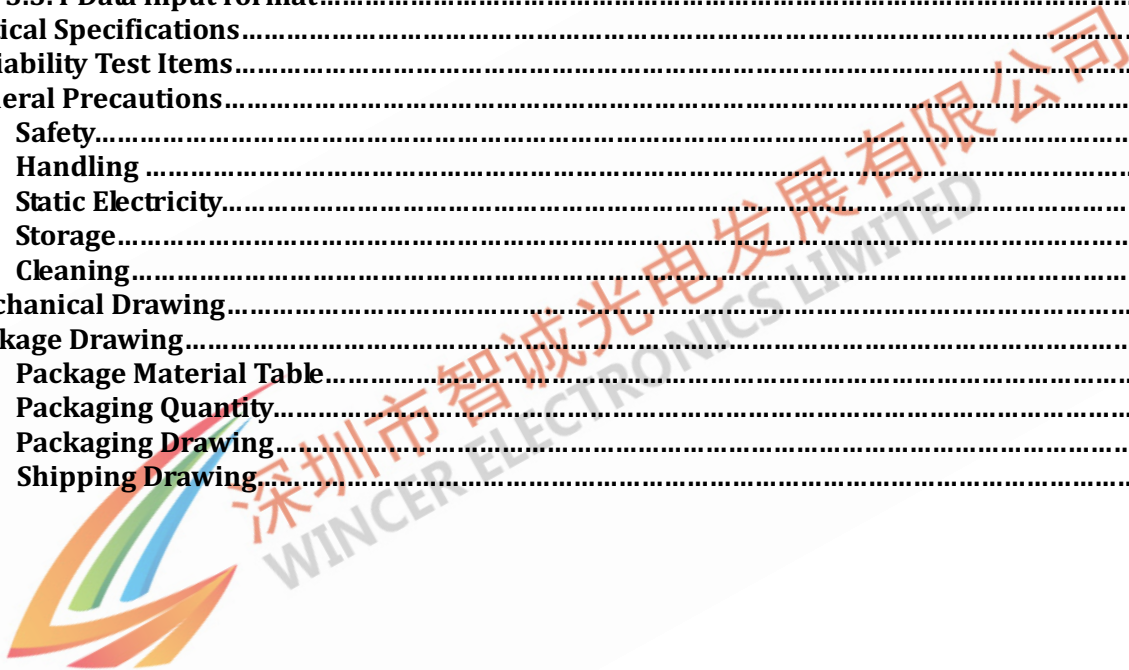

1. General Specifications

No.	Item	Specification	Remark
1	LCD size	7.0 inch (Diagonal)	
2	Driver element	a-Si TFT active matrix	
3	Resolution	800 × 3(RGB) × 480	
4	Display mode	Normally White, Transmissive	
5	Dot pitch	0.0642(W) × 0.1790(H) mm	
6	Active area	154.08(W) × 85.92(H) mm	
7	Module size	164.9(W) × 100.0(H) × 5.7(D) mm	Note 1
8	Bezel opening size	157.08(W) × 88.92(H) mm	
9	Surface treatment	Anti-Glare	
10	Color arrangement	RGB-stripe	
11	Interface	Digital	
12	Backlight power consumption	4.2 W(Typ.)	
13	Panel power consumption	0.226W (Typ.)	
14	Weight	150g (Max.)	

Note 1: Refer to Mechanical Drawing.

2. Pin Assignment

FPC Connector is used for the module electronics interface. The recommended model is FH12A-50S-0.5SH manufactured by Hirose.

Pin No.	Symbol	I/O	Function	Remark
1	V _{LED+}	P	Power for LED backlight (Anode)	
2	V _{LED+}	P	Power for LED backlight (Anode)	
3	V _{LED-}	P	Power for LED backlight (Cathode)	
4	V _{LED-}	P	Power for LED backlight (Cathode)	
5	GND	P	Power ground	
6	V _{COM}	I	Common voltage	
7	DV _{DD}	P	Power for Digital Circuit	
8	MODE	I	DE/SYNC mode select	Note 1
9	DE	I	Data Input Enable	
10	VS	I	Vertical Sync Input	
11	HS	I	Horizontal Sync Input	
12	B7	I	Blue data(MSB)	
13	B6	I	Blue data	
14	B5	I	Blue data	
15	B4	I	Blue data	
16	B3	I	Blue data	
17	B2	I	Blue data	
18	B1	I	Blue data	Note 2
19	B0	I	Blue data(LSB)	Note 2
20	G7	I	Green data(MSB)	
21	G6	I	Green data	
22	G5	I	Green data	
23	G4	I	Green data	
24	G3	I	Green data	
25	G2	I	Green data	

26	G1	I	Green data	Note 2
27	G0	I	Green data(LSB)	Note 2
28	R7	I	Red data(MSB)	
29	R6	I	Red data	
30	R5	I	Red data	
31	R4	I	Red data	
32	R3	I	Red data	
33	R2	I	Red data	
34	R1	I	Red data	Note 2
35	R0	I	Red data(LSB)	Note 2
36	GND	P	Power Ground	
37	DCLK	I	Sample clock	Note 3
38	GND	P	Power Ground	
39	L/R	I	Left / right selection	Note 4,5
40	U/D	I	Up/down selection	Note 4,5
41	V _{GH}	P	Gate ON Voltage	
42	V _{GL}	P	Gate OFF Voltage	
43	AV _{DD}	P	Power for Analog Circuit	
44	RESET	I	Global reset pin.	Note 6
45	NC	-	No connection	
46	V _{COM}	I	Common Voltage	
47	DITHB	I	Dithering function	Note 7
48	GND	P	Power Ground	
49	NC	-	No connection	
50	NC	-	No connection	

I: input, O: output, P: Power

Note 1: DE/SYNC mode select. Normally pull high.

When select DE mode, MODE="1", VS and HS must pull high.

When select SYNC mode, MODE="0", DE must be grounded.

Note 2: When input 18 bits RGB data, the two low bits of R,G and B data must be grounded.

Note 3: Data shall be latched at the falling edge of DCLK.

Note 4: Selection of scanning mode

Setting of scan control input		Scanning direction
U/D	L/R	
GND	DV _{DD}	Up to down, left to right
DV _{DD}	GND	Down to up, right to left
GND	GND	Up to down, right to left
DV _{DD}	DV _{DD}	Down to up, left to right

Note 5: Definition of scanning direction.

Refer to the figure as below:

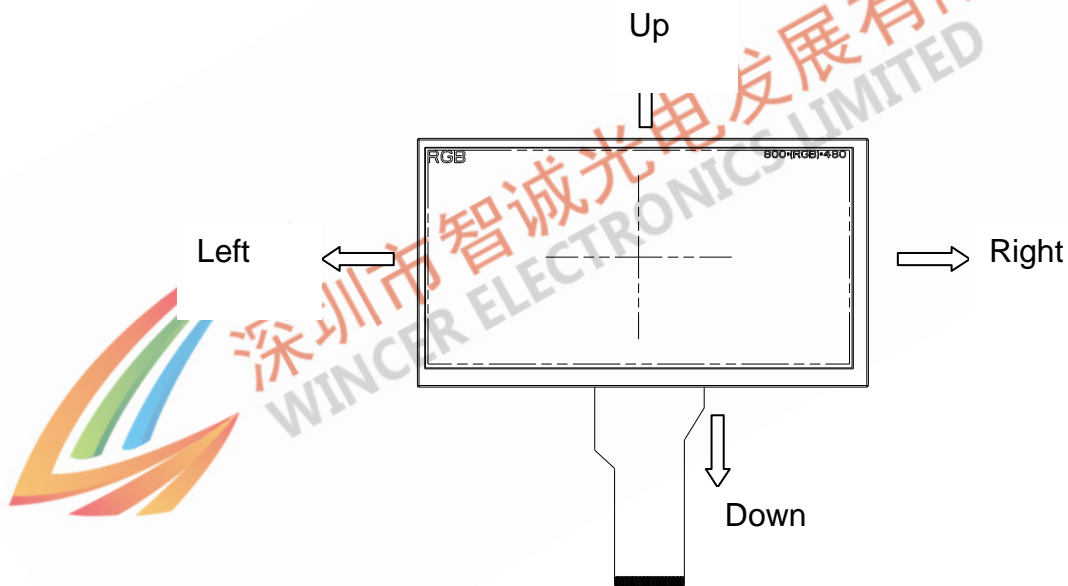

Note 6: Global reset pin. Active low to enter reset state. Suggest to connect with an RC reset circuit for stability. Normally pull high.

Note 7: Dithering function enable control, normally pull high.

When DITHB="1", Disable internal dithering function,

When DITHB="0", Enable internal dithering function,

3. Operation Specifications

3.1. Absolute Maximum Ratings

Item	Symbol	Values		Unit	Remark
		Min.	Max.		
Power voltage	DV_{DD}	-0.3	5.0	V	
	AV_{DD}	6.5	13.5	V	
	V_{GH}	-0.3	40.0	V	
	V_{GL}	-20.0	0.3	V	
	$V_{GH}-V_{GL}$	-	40.0	V	
Operation Temperature	T_{OP}	-30	85	°C	
Storage Temperature	T_{ST}	-40	90	°C	
LED Reverse Voltage	VR	-	5	V	Each LED Note 2
LED Forward Current	IF	-	70	mA	Each LED

Note 1: The absolute maximum rating values of this product are not allowed to be exceeded at any times. Should a module be used with any of the absolute maximum ratings exceeded, the characteristics of the module may not be recovered, or in an extreme case, the module may be permanently destroyed.

Note 2 : VR conditions : Zener Diode 20mA

3.1.1. Typical Operation Conditions

Item	Symbol	Values			Unit	Remark
		Min.	Typ.	Max.		
Power voltage	DV _{DD}	3.0	3.3	3.6	V	Note 2
	AV _{DD}	10.2	10.4	10.6	V	
	V _{GH}	15.3	16.0	16.7	V	
	V _{GL}	-7.7	-7.0	-6.3	V	
Input signal voltage	V _{COM}	2.6	(3.6)	4.6	V	Note 4
Input logic high voltage	V _{IH}	0.7 DV _{DD}	-	DV _{DD}	V	Note 3
Input logic low voltage	V _{IL}	0	-	0.3 DV _{DD}	V	

Note 1: Be sure to apply DV_{DD} and V_{GL} to the LCD first, and then apply V_{GH}.

Note 2: DV_{DD} setting should match the signals output voltage (refer to Note 3) of customer's system board.

Note 3: DCLK,HS,VS,RESET,U/D, L/R,DE,R0~R7,G0~G7,B0~B7,MODE,DITHB.

Note 4: Typical V_{COM} is only a reference value. It must be optimized according to each LCM. Please use VR and base on below application circuit.

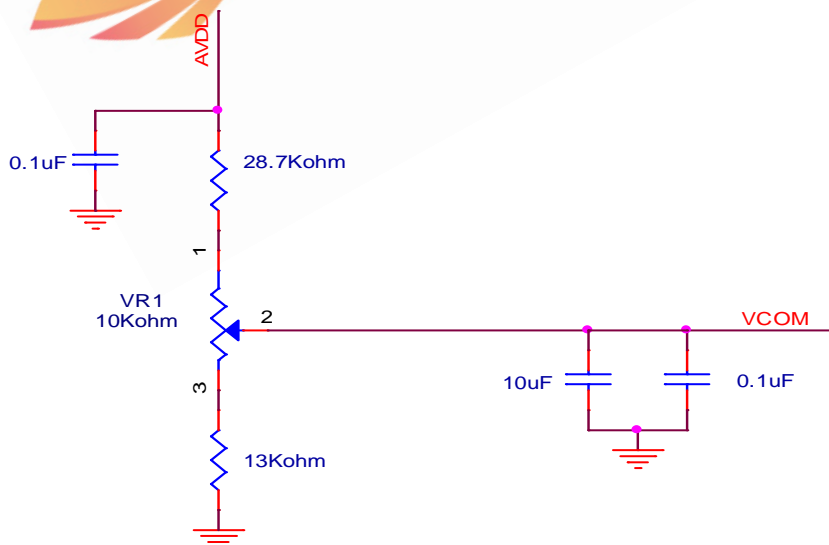

3.1.2. Current Consumption

Item	Symbol	Values			Unit	Remark
		Min.	Typ.	Max.		
Current for Driver	I_{GH}	-	0.2	1.0	mA	$V_{GH} = 16.0V$
	I_{GL}	-	0.2	1.0	mA	$V_{GL} = -7.0V$
	IDV_{DD}	-	4.0	10	mA	$DV_{DD} = 3.3V$
	$I_{AV_{DD}}$	-	20	50	mA	$AV_{DD} = 10.4V$

3.1.3. Backlight Driving Conditions

Item	Symbol	Values			Unit	Remark
		Min.	Typ.	Max.		
Voltage for LED backlight	V_L	19.6	21.7	23.8	V	Note 1
Current for LED backlight	I_L	-	192	-	mA	
LED life time	-	20,000	-	-	Hr	Note 2

Note 1: The LED Supply Voltage is defined by the number of LED at $T_a = 25^\circ C$ and $I_L = 180mA$

Note 2: The "LED life time" is defined as the module brightness decrease to 50% original brightness at $T_a = 25^\circ C$ and $I_L = 180mA$. The LED lifetime could be decreased if operating I_L is larger than 180mA.

3.2. Power Sequence

a. Power on:

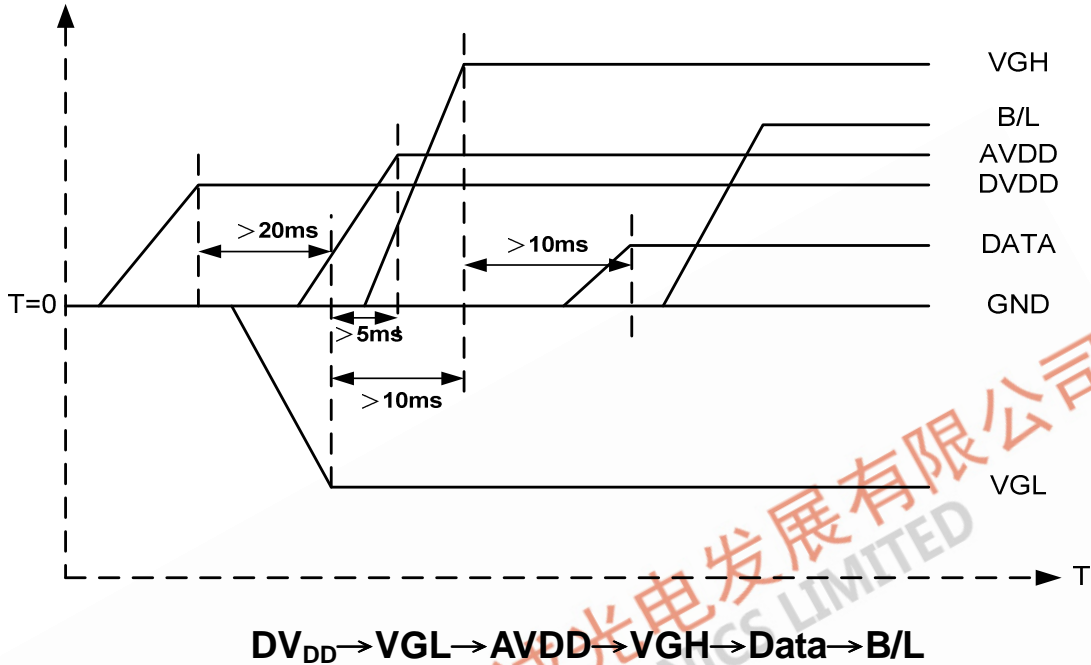

b. Power off:

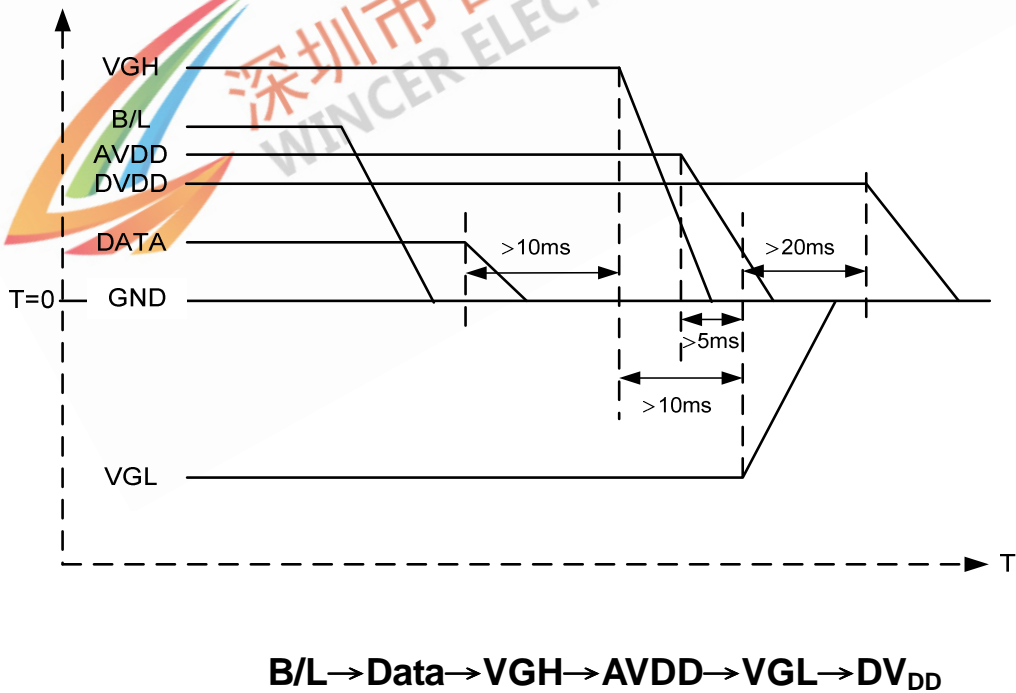

Note: Data include R0~R7, B0~B7, GO~G7, U/D, L/R, DCLK, HS,VS,DE.

3.3. Timing Characteristics

3.3.1. AC Electrical Characteristics

Item	Symbol	Values			Unit	Remark
		Min.	Typ.	Max.		
HS setup time	Thst	8	-	-	ns	
HS hold time	Thhd	8	-	-	ns	
VS setup time	Tvst	8	-	-	ns	
VS hold time	Tvhd	8	-	-	ns	
Data setup time	Tdsu	8	-	-	ns	
Data hole time	Tdhd	8	-	-	ns	
DE setup time	Tesu	8	-	-	ns	
DE hole time	Tehd	8	-	-	ns	
DV _{DD} Power On Slew rate	TPOR	-	-	20	ms	From 0 to 90% DV _{DD}
RESET pulse width	TRst	1	-	-	ms	
DCLK cycle time	Tcoh	20	-	-	ns	
DCLK pulse duty	Tcwh	40	50	60	%	

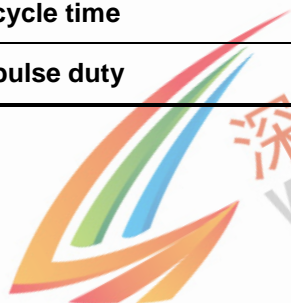

深圳市智誠光電發展有限公司
WINCER ELECTRONICS LIMITED

3.3.2. Input Clock and Data Timing Diagram

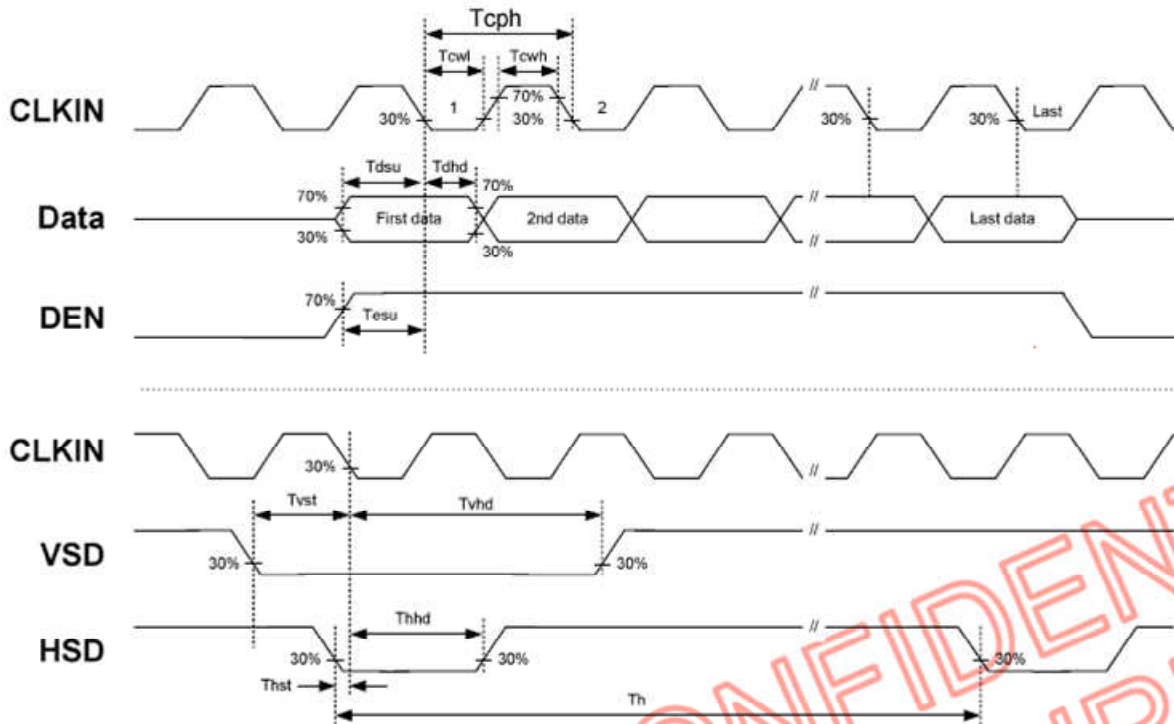

3.3.3. Timing

Item	Symbol	Values			Unit	Remark
		Min.	Typ.	Max.		
Horizontal Display Area	thd	-	800	-	DCLK	
DCLK Frequency	fclk	26.4	33.3	46.8	MHz	
One Horizontal Line	th	862	1056	1200	DCLK	
HS pulse width	thpw	1	-	40	DCLK	
HS Blanking	thb	46	46	46	DCLK	
HS Front Porch	thfp	16	210	354	DCLK	

Item	Symbol	Values			Unit	Remark
		Min.	Typ.	Max.		
Vertical Display Area	tvd	-	480	-	TH	
VS period time	tv	510	525	650	TH	
VS pulse width	tvpw	1	-	20	TH	
VS Blanking	tvb	23	23	23	TH	
VS Front Porch	tvfp	7	22	147	TH	

3.3.4. Data Input Format

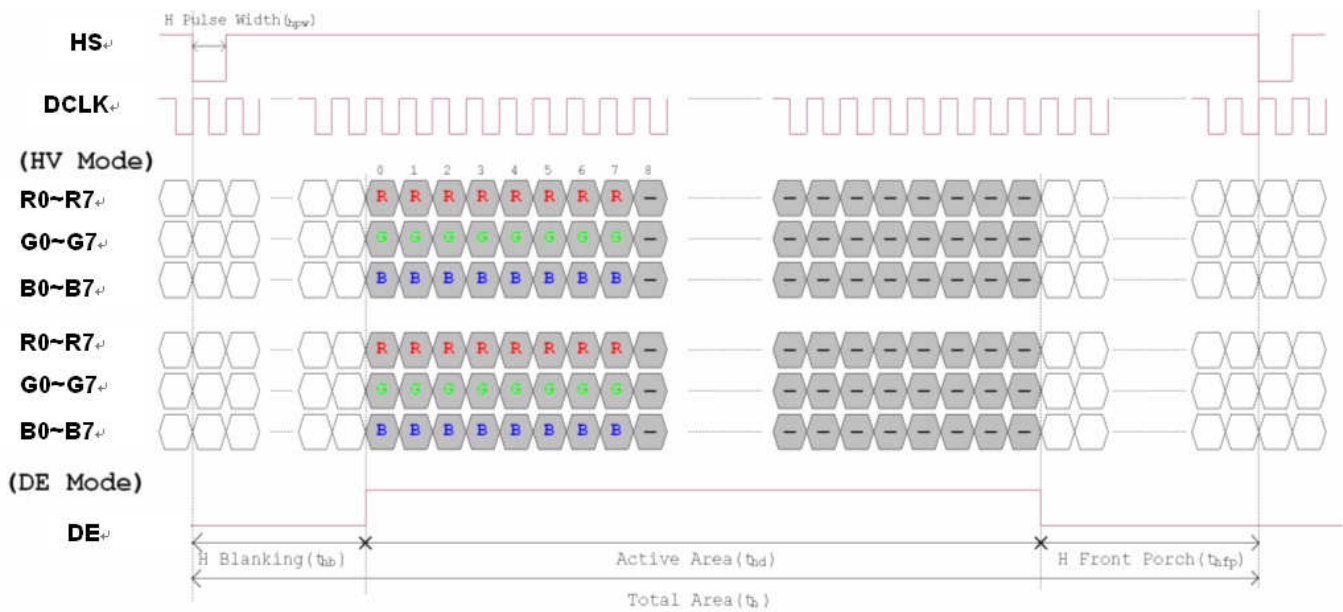

Figure 3. 1 Horizontal input timing diagram.

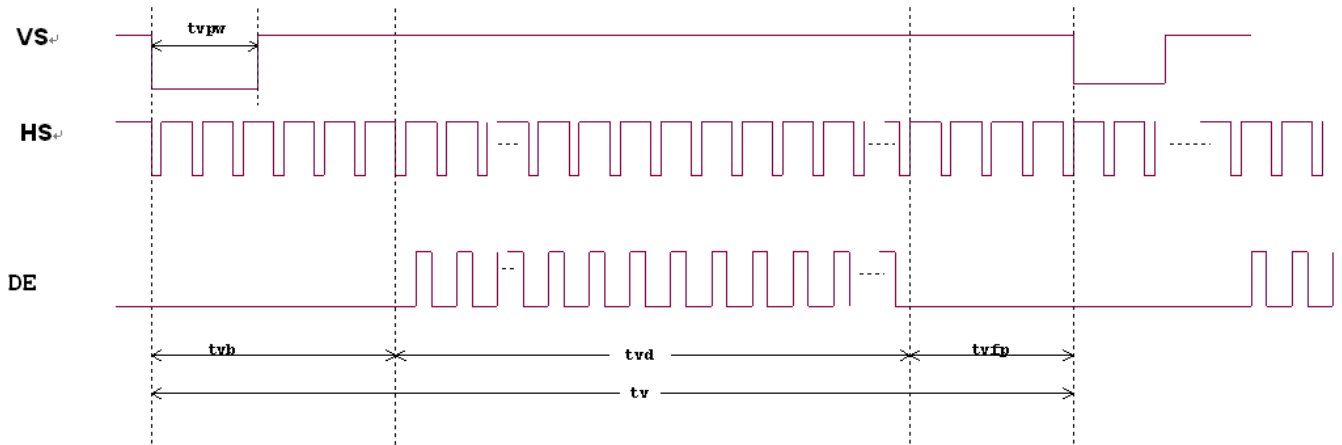

Figure 3. 2 Vertical input timing diagram.



4. Optical Specifications

Item	Symbol	Condition	Values			Unit	Remark
			Min.	Typ.	Max.		
Viewing angle (CR≥ 10)	θ_L	$\Phi=180^\circ$ (9 o'clock)	60	70	-	degree	Note 1
	θ_R	$\Phi=0^\circ$ (3 o'clock)	60	70	-		
	θ_T	$\Phi=90^\circ$ (12 o'clock)	40	50	-		
	θ_B	$\Phi=270^\circ$ (6 o'clock)	60	70	-		
Response time	T_{ON}	Normal $\theta=\Phi=0^\circ$	-	10	20	msec	Note 3
	T_{OFF}		-	15	30	msec	Note 3
Contrast ratio	CR		400	500	-	-	Note 4
Color chromaticity	W_x	Normal $\theta=\Phi=0^\circ$	0.26	0.31	0.36	-	Note 2 Note 5 Note 6
	W_y		0.28	0.33	0.38	-	
Luminance	L		600	-	-	cd/m ²	Note 6
Luminance uniformity	Y_U		70	75	-	%	Note 7

Test Conditions:

1. $DV_{DD}=3.3V$, $I_L=192mA$ (Backlight current), the ambient temperature is 25°C.
2. The test systems refer to Note 2.

Note 1: Definition of viewing angle range

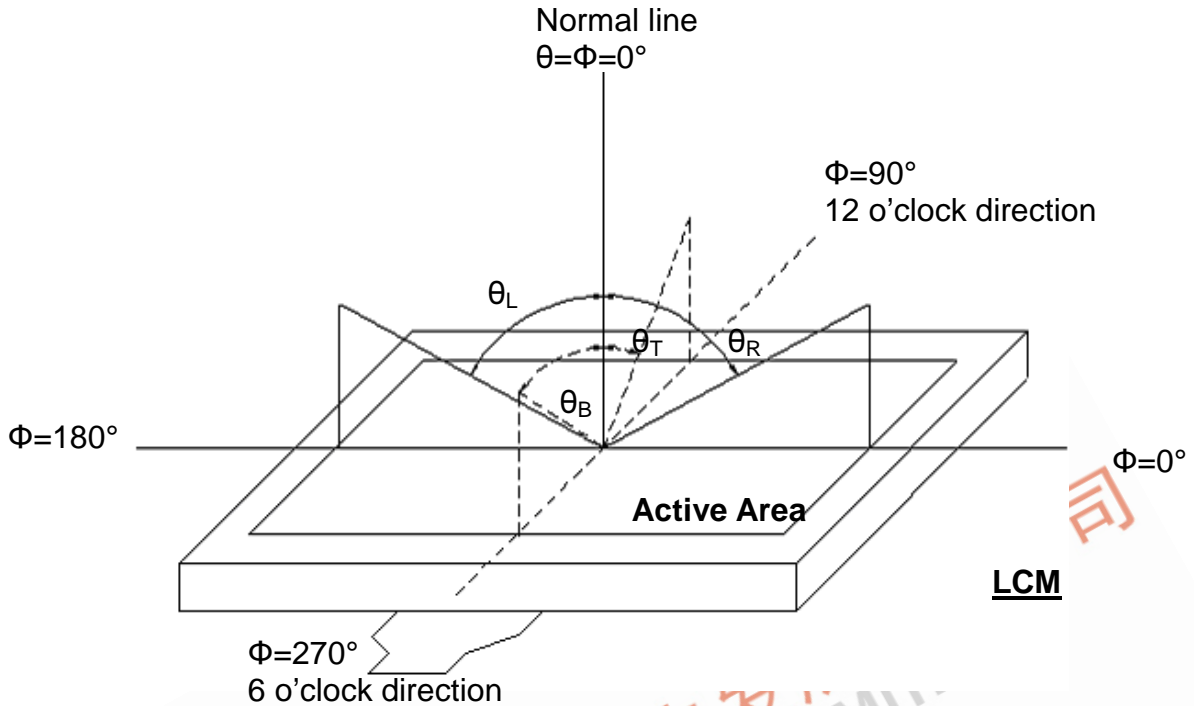

Fig. 4-1 Definition of viewing angle

Note 2: Definition of optical measurement system.

The optical characteristics should be measured in dark room. After 30 minutes operation, the optical properties are measured at the center point of the LCD screen. (Response time is measured by Photo detector TOPCON BM-7, other items are measured by BM-5A/Field of view: 1°/Height: 500mm.)

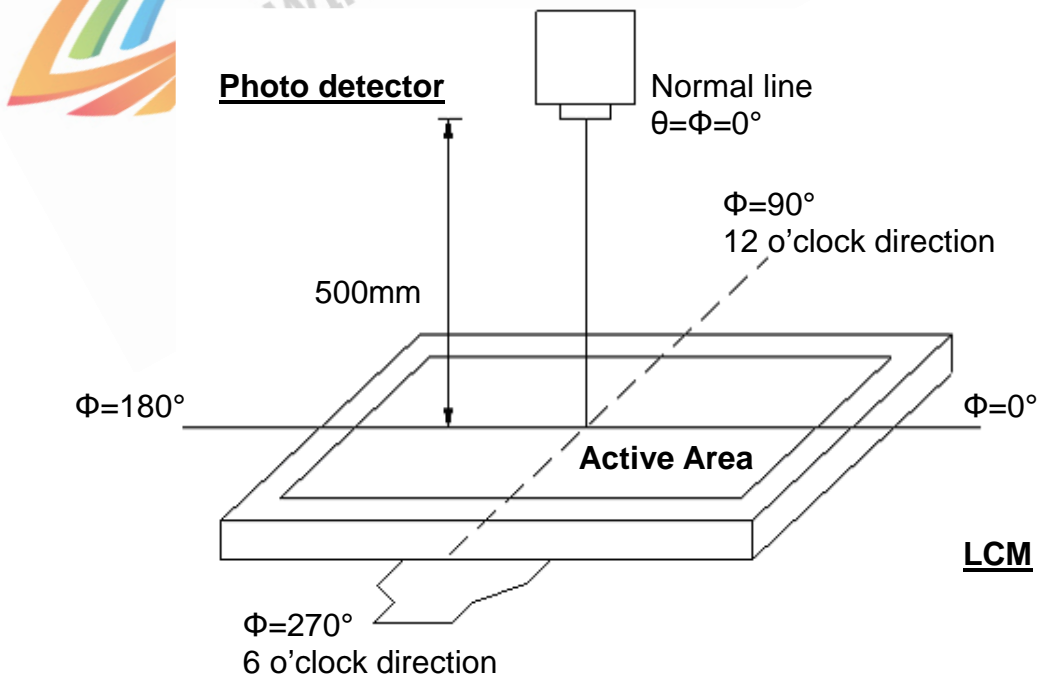

Fig. 4-2 Optical measurement system setup

Note 3: Definition of Response time

The response time is defined as the LCD optical switching time interval between “White” state and “Black” state. Rise time (T_{ON}) is the time between photo detector output intensity changed from 90% to 10%. And fall time (T_{OFF}) is the time between photo detector output intensity changed from 10% to 90%.

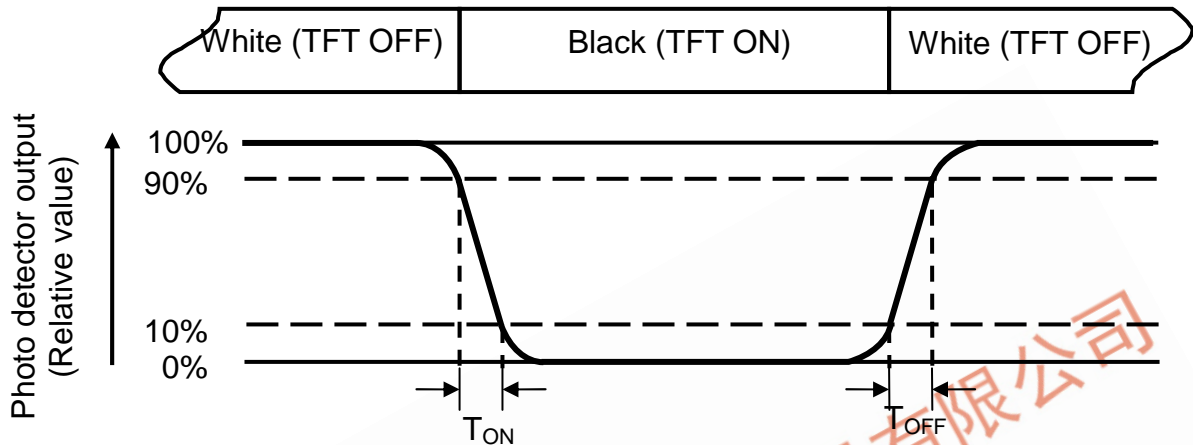

Fig. 4-3 Definition of response time

Note 4: Definition of contrast ratio

$$\text{Contrast ratio (CR)} = \frac{\text{Luminance measured when LCD on the "White" state}}{\text{Luminance measured when LCD on the "Black" state}}$$

Note 5: Definition of color chromaticity (CIE1931)

Color coordinates measured at center point of LCD.

Note 6: All input terminals LCD panel must be ground while measuring the center area of the panel. The LED driving condition is $I_L=192\text{mA}$

Note 7: Definition of Luminance Uniformity

Active area is divided into 9 measuring areas (Refer to Fig. 4-4).Every measuring point is placed at the center of each measuring area.

$$\text{Luminance Uniformity (Yu)} = \frac{B_{min}}{B_{max}}$$

L-----Active area length W----- Active area width

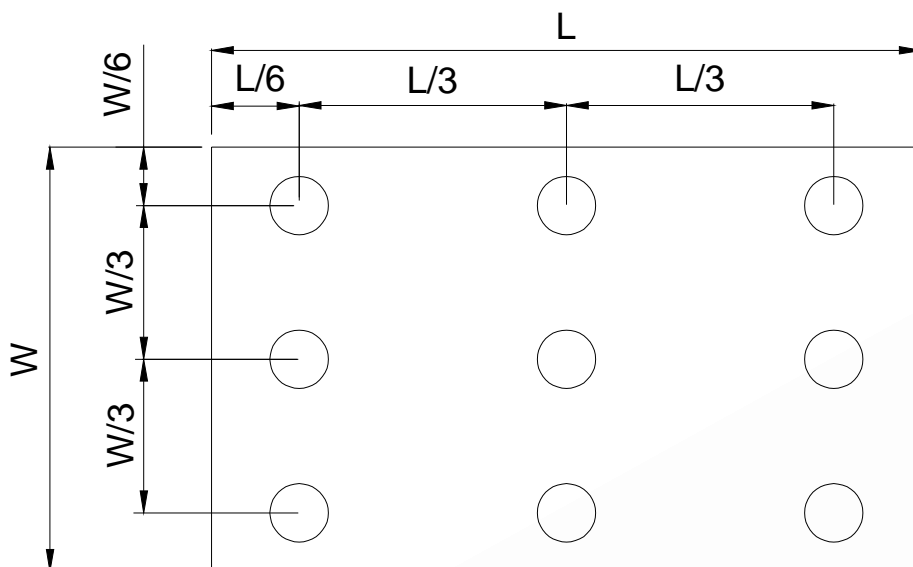

Fig. 4-4 Definition of measuring points

B_{max} : The measured maximum luminance of all measurement position.
 B_{min} : The measured minimum luminance of all measurement position.



深圳市智誠光電發展有限公司
WINCER ELECTRONICS LIMITED

5. Reliability Test Items

Item	Test Conditions	Remark
High Temperature Storage Test	90°C, 240 hours	(1) (2)
Low Temperature Storage Test	-40°C, 240 hours	
High Temperature Operation Test	85°C, 240 hours	
Low Temperature Operation Test	-30°C, 240 hours	
High Temperature & High Humidity Operation Test	60°C, RH 90%, 240hours	
Thermal Shock	(-30°C 30min)→(85°C 30min)]/cycle , (Ramp rate ≥ 20°C /min) , 100cycles	
ESD Test (Non-Operation)	Condition 1 : C = 150pF, R = 330Ω Contact Discharge, ± 8KV Condition 2 : C = 150pF, R = 330Ω, Air Discharge, ± 15KV	(1)
Mechanical Shock	100G for half sine 2 ms, 6 sides, for directions of ±X, ±Y, ±Z	(1)(3)
Mechanical Vibration	Frequency: 10 ~55~10Hz; Sweep Mode: Log Sweep Sweep time: 1Oct/min; Acceleration: 1.5G; Test time: 2 hr for each direction of X, Y, Z.	(1)(3)
Packaging Vibration Test	1.47Grms X, Y, Z three axes (30min /axis) [頻譜 : 5Hz(0.015G ² /Hz) , 100Hz(0.015G ² /Hz) , 200Hz(0.0037G ² /Hz)]	
Packaging Drop Test	高度: 72cm(weight ≤ 10kg), 60cm(weight > 10kg); 1times for 6-faces, 3-edges and 1-corner	

Note (1) criteria : Normal display image with no obvious non-uniformity and no line defect.

Note (2) Evaluation should be tested after storage at room temperature for more than two hour

Note (3) At testing Vibration and Shock, the fixture in holding the module has to be hard and rigid enough so that the module would not be twisted or bent by the fixture.

6. General Precautions

6.1. Safety

Liquid crystal is poisonous. Do not put it in your mouth. If liquid crystal touches your skin or clothes, wash it off immediately by using soap and water.

6.2. Handling

1. The LCD panel is plate glass. Do not subject the panel to mechanical shock or to excessive force on its surface.
2. The polarizer attached to the display is easily damaged. Please handle it carefully to avoid scratch or other damages.
3. To avoid contamination on the display surface, do not touch the module surface with bare hands.
4. Keep a space so that the LCD panels do not touch other components.
5. Put cover board such as acrylic board on the surface of LCD panel to protect panel from damages.
6. Transparent electrodes may be disconnected if you use the LCD panel under environmental conditions where the condensation of dew occurs.
7. Do not leave module in direct sunlight to avoid malfunction of the ICs.

6.3. Static Electricity

1. Be sure to ground module before turning on power or operating module.
2. Do not apply voltage which exceeds the absolute maximum rating value.

6.4. Storage

1. Store the module in a dark room where must keep at $25\pm 10^{\circ}\text{C}$ and 65%RH or less.
2. Do not store the module in surroundings containing organic solvent or corrosive gas.
3. Store the module in an anti-electrostatic container or bag.

6.5. Cleaning

1. Do not wipe the polarizer with dry cloth. It might cause scratch.
2. Only use a soft sloth with IPA to wipe the polarizer, other chemicals might permanent damage to the polarizer.

7. Mechanical Drawing

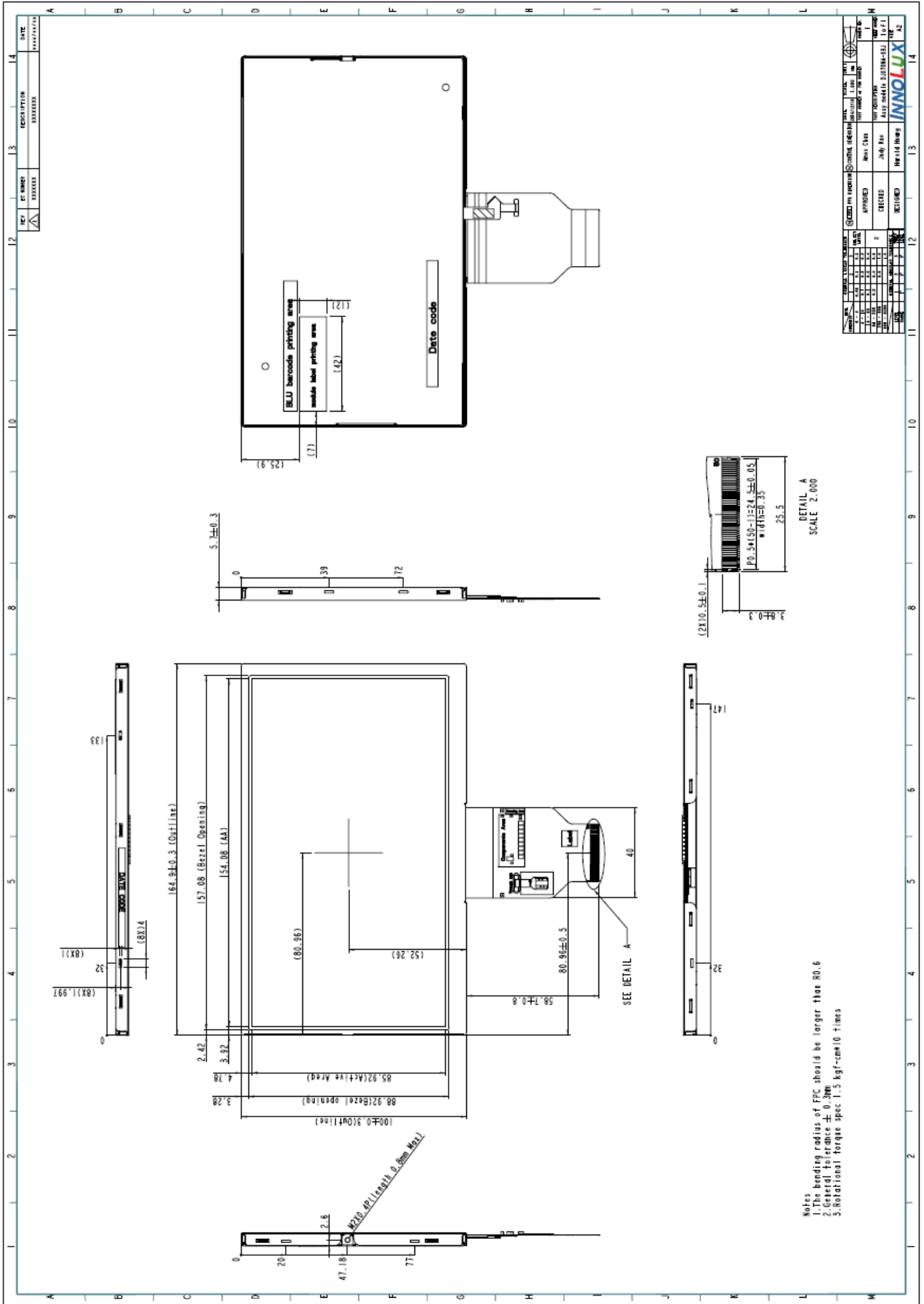

Notes
 1. The bending radius of FPC should be larger than R0.6
 2. General tolerance ±0.3mm
 3. Rotational torque spec 1.5 kgf-cm/10 Times

DETAIL A
 SCALE 2.000

NO.	REV.	DATE	DESCRIPTION
1	1	2014.11.11	INITIAL RELEASE
2	1	2014.11.11	INITIAL RELEASE
3	1	2014.11.11	INITIAL RELEASE
4	1	2014.11.11	INITIAL RELEASE
5	1	2014.11.11	INITIAL RELEASE
6	1	2014.11.11	INITIAL RELEASE
7	1	2014.11.11	INITIAL RELEASE
8	1	2014.11.11	INITIAL RELEASE
9	1	2014.11.11	INITIAL RELEASE
10	1	2014.11.11	INITIAL RELEASE
11	1	2014.11.11	INITIAL RELEASE
12	1	2014.11.11	INITIAL RELEASE
13	1	2014.11.11	INITIAL RELEASE
14	1	2014.11.11	INITIAL RELEASE

8. Package Drawing

8.1 Packaging Material Table

No.	Item	Model (Material)	Dimensions(mm)	Unit Weight (kg)	Quantity	Remark
1	LCM Module	Model name	192.8 x 116.9 x 6.4	0.15	30pcs	
2	EPO Box	EPO	376 x 330 x 241	0.657	1	
3	A/S Bag	PE	205 x 190 x 0.08	0.0061	30	
4	Carton	Corrugated paper	398 x 352 x 273	0.9	1	
5	Total weight	TBD				

8.2 Packaging Quantity

Total LCM quantity in Carton: no. of Partition 1 Rows x quantity per Row 30 = 30
--

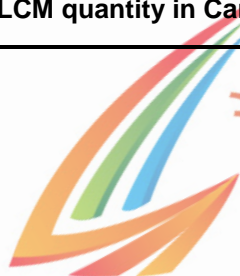

深圳市智誠光電發展有限公司
WINCER ELECTRONICS LIMITED

8.3. Packaging Drawing

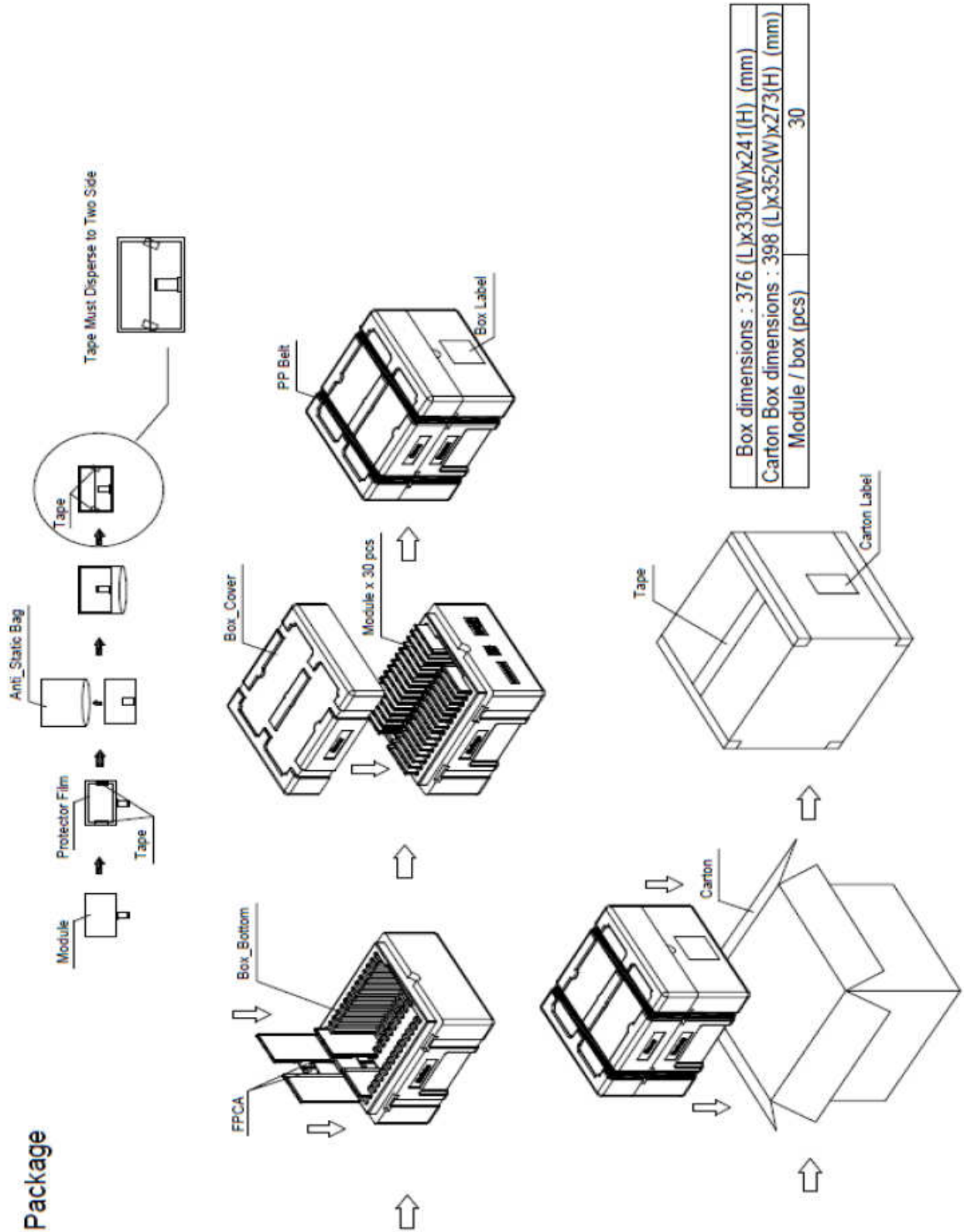

8.4. Shipping Drawing

Shipping

Top View
1150
352
358
340

Front View
(Sea trans for normal cont)
2474
1237
2201

Pallet Type .

Destination For customer	Material Wood	Pallet size L1150xW840xH145
--------------------------	---------------	-----------------------------

Trans type	Box / Top Pallet	Box / Bottom Pallet
Air	0	30
Sea	18	24
Sea for HQ	24	24

Storage Condition

Destination	Value	Unit
Temperature	0~35	°C
Humidity	40~80	%RH

Front View
(Sea trans for HQ)

Front View
(Sea trans for normal cont)

Front View
(Air trans)