

TFT LCD Preliminary Specification

MODEL NO.: N7 %\$(AT9001

Customer : _____

Approved by : _____

Note :



紀錄	工作	審核	角色	投票
				Accept

Contents

No.	Item	Page
0	Record of Revision	3
1	Summary	4
2	Features	4
3	General Specifications	4
4	Absolute Maximum Rating	4
5	Electrical Characteristics	5
6	DC Characteristics	6
7	AC Characteristics	7-9
8	Optical Characteristics	10-12
9	Interface Pin Connection	13-14
10	Block Diagram	15
11	Quality Assurance	15
12	Outline Drawing	16
13	Package Form	17
14	Precautions	18-19

Record of Revision

Version	Date	Page (New)	Section	Description
1.0	2019/8/14	All	All	
1.1	2	5 15 17		
1.2	2	10		



1. Summary

ZC104AT9001 is a transmissive type color active matrix liquid crystal display (LCD), which uses amorphous thin film transistor (TFT) as switching devices. This panel has a 10.4 inches diagonally measured active display area with SVGA (800 RGB x 600) resolution. The following describes the features of this product.

2. Features

- 10.4" (diagonal) inch configuration
- SVGA (800x600 pixels) resolution

3. General Specifications

No.	Item	Specification	Unit
1	Screen Size	10.4 (Diagonal)	inch
2	Display Resolution	800 RGB x 600	pixel
3	Dot Pitch	0.088 (H) x 0.264 (V)	mm
4	Pixel Pitch	0.264 (H) x 0.264 (V)	mm
5	Active Area	211.2(H) x 158.4(V)	mm
6	Outline Dimension	228.4 (H) x 175.4 (V) x 5.9 (D)	mm
7	Pixel Configuration	RGB-Stripe	--
8	Color Depth	16.2M	colors
9	LCD Type	TM TN	--
10	Interface Type	Digital 24bit RGB	--
11	Surface Treatment	3H	--
12	View direction (Gray inversion)	6 o'clock	--
13	Weight	390	g

4. Absolute Maximum Rating

(Ta = 25 ± 2°C)

Item	Symbol	Values		Unit	Note
		Min.	Max.		
Storage Temperature	T _{ST}	-30	80	°C	
Operation Temperature	T _{OP}	-20	70	°C	
Digital Supply Voltage	VCC	-0.3	5	V	(2)
Analog Power Supply Voltage	AVDD	-0.5	15	V	(3)
TFT Device on voltage	V _{GH}	-0.3	42	V	(4)
TFT Device off voltage	V _{GL}	V _{GH} - 42	0.3	V	(4)

Note:

- (1) All of the voltages listed above are with respect to GND= 0V
- (2) Device is subject to be damaged permanently if stresses beyond those absolute maximum ratings listed above.

5. Electrical Characteristics

5-1. Operating Conditions:

(Ta = 25 ± 2°C)

Item	Symbol	Values			Unit	Note
		Min.	Typ.	Max.		
Digital Power Supply Voltage	VCC	3.0	3.3	3.6	V	
Digital Supply Current	I _{CC}	24	30	45	mA	Black Pattern
Analog Power Supply Voltage	AVDD	11.5	12	12.5	V	
Analog Supply Current	I _{AVDD}	32	40	60	mA	Black Pattern
TFT Device on voltage	V _{GH}	-	(18)	-	V	
TFT Device off voltage	V _{GL}	-	(-7)	-	V	
Common Electrode Driving Voltage	VCOM	-	5.3	-	V	
LED Reverse Voltage	V _r			1.5	V	For single LED
LED Forward Current	I _f		20	30	mA	For single LED

5-2. Backlight Driving Conditions:

(Ta = 25 ± 2°C)

Item	Symbol	Values			Unit	Note
		Min.	Typ.	Max.		
Power Consumption	P _{BL}	--	2.304	2.52	W	--
LED Current	I _F	--	240	--	mA	--
Backlight Voltage	V _{BL}	--	9.6	10.5	V	--
Life Time	--	10000	--	--	hrs	(1)

Note:

(1) Brightness to be decreased to 50% of the initial value

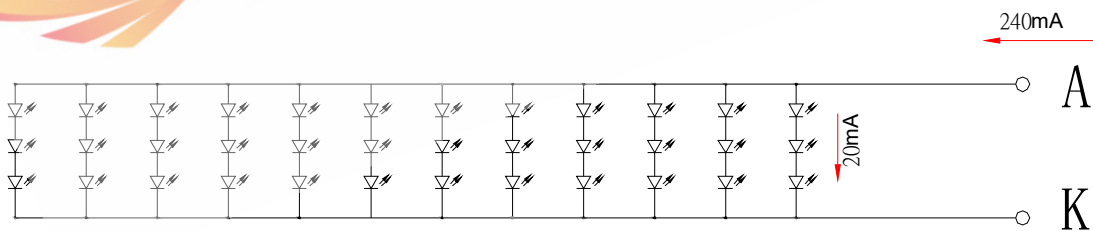

6. DC Characteristics

6.1 Parameter

(Ta = 25 ± 2°C)

Item	Symbol	Values			Unit	Note
		Min.	Typ.	Max.		
Low Level Input Voltage	V _{IL}	0	-	0.3VCC	V	(1)
High Level Input Voltage	V _{IH}	0.7 VCC	-	VCC	V	(1)

Note:

(1) For Digital Circuit

6.2 Power Sequence

The LCD panel power ON/OFF sequence is as below

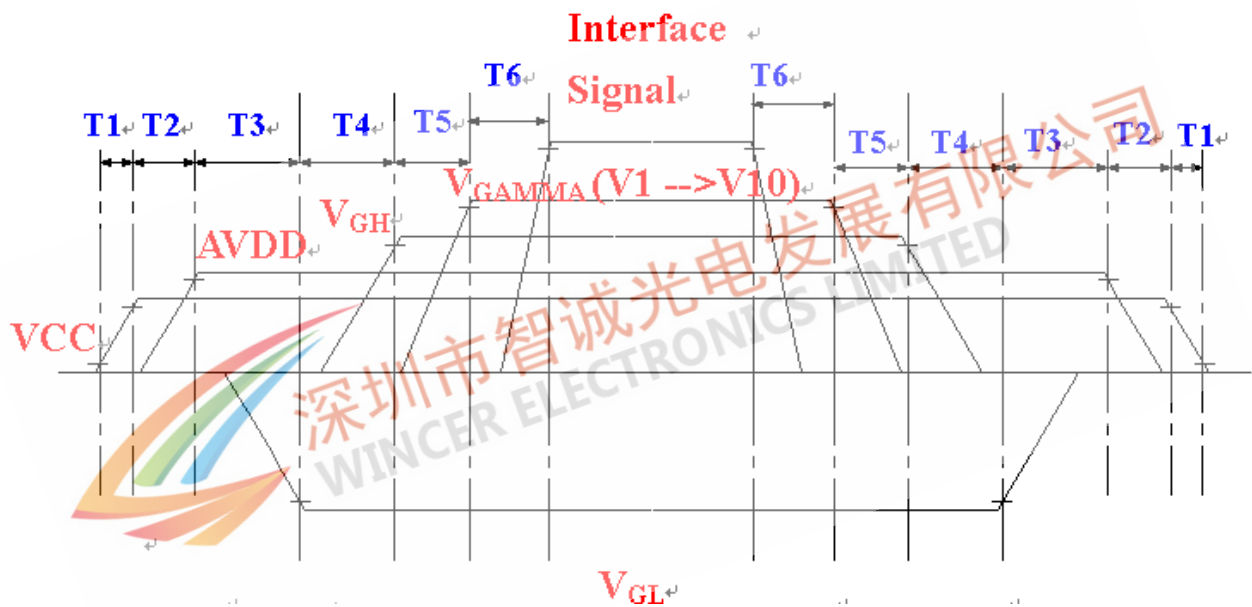

	Min.	Typ.	Max.	Unit
T1	-	-	20	ms
T2	16	-	-	ms
T3	> 0			ms
T4	> 0			ms
T5	> 0			ms
T6	> 0			ms

7. AC Characteristics

7.1. Data Timing (Under frame rate is equal to 60Hz)

• Horizontal Timing

Parameter	Symbol	Spec			Unit
		Min.	Typ.	Max.	
Horizontal Display Area	thd	800			CLK
CLK Frequency	fclk	-	40	50	MHz
One Horizontal Line	th	862	1056	1200	CLK
HS Pulse Width	thpw	1	-	40	CLK
HS Back Porch	thb	46			CLK
HS Front Porch	thfp	16	210	354	CLK

• Vertical Timing

Parameter	Symbol	Spec			Unit
		Min.	Typ.	Max.	
Vertical Display Area	tvd	600			th
VS Period Time	tv	624	635	700	th
VS Pulse Width	tvpw	1	-	20	th
VS Back Porch	tvb	23	23	23	th
VS Front Porch	tvfp	1	12	77	th

Note:

CMO suggest using frame rate 60Hz to have better performance

Horizontal Timing

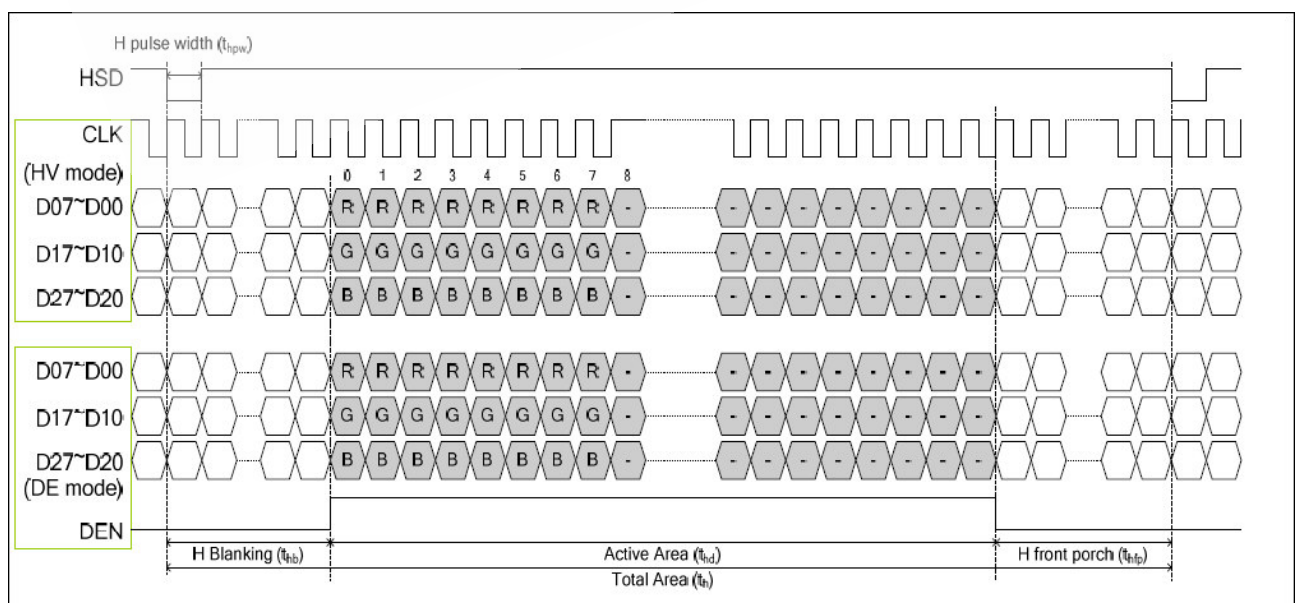

Vertical Timing

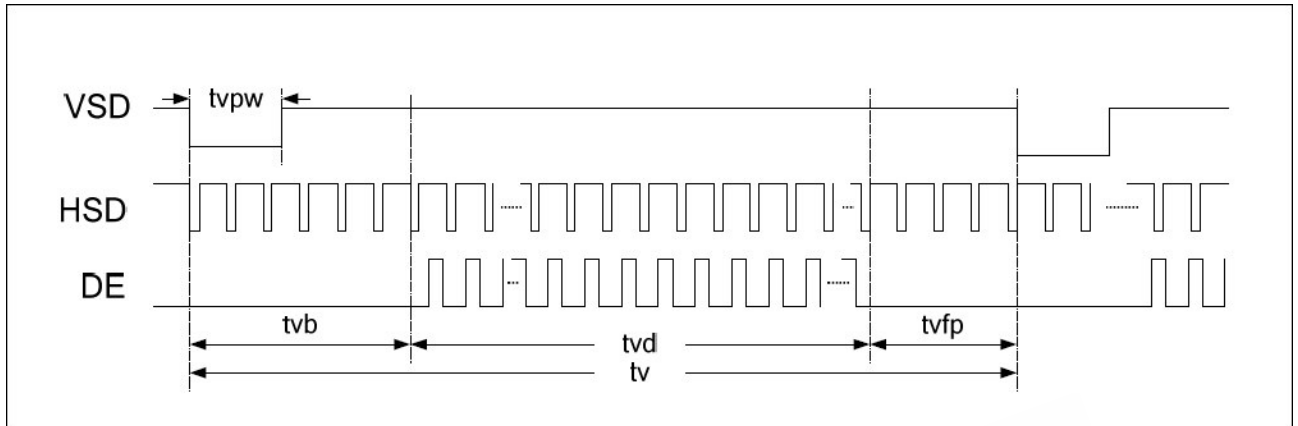

7.2. AC Electrical characteristic

Parameter	Symbol	Spec.			Unit
		Min.	Typ.	Max.	
HS setup time	T_{hst}	8	-	-	ns
HS hold time	T_{hhd}	8	-	-	ns
VS setup time	T_{vst}	8	-	-	ns
VS hold time	T_{vhd}	8	-	-	ns
Data setup time	T_{dsu}	8	-	-	ns
Data hold time	T_{dhd}	8	-	-	ns
DE setup time	T_{esu}	8	-	-	ns
DE hold time	T_{ehd}	8	-	-	ns
VDD Power On Slew Rate	T_{POR}	-	-	20	ms
RSTB pulse width	T_{Rst}	10	-	-	us
CLKIN cycle time	T_{cph}	20	-	-	ns
CLKIN pulse duty	T_{cwh}	40	50	60	%
Output stable time	T_{sst}	-	-	6	ns
Repair OPA Output Stable time	T_{Rsst}	-	-	6	ns

7.3. Input Clock and Data Timing Waveform

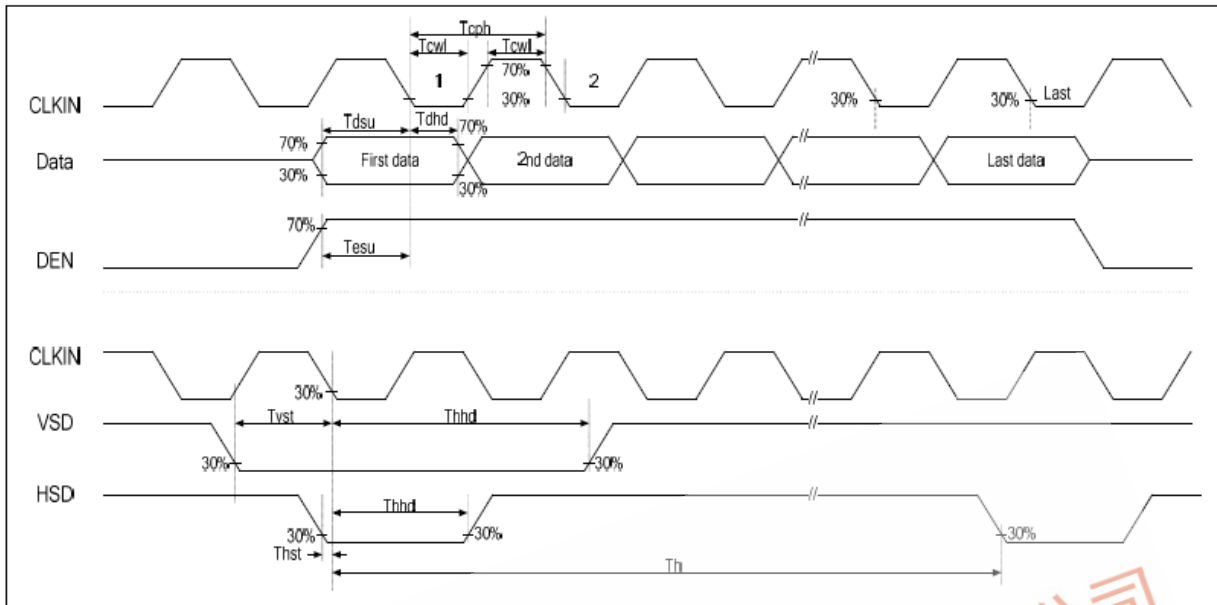

8. Optical Characteristics

($T_a = 25 \pm 2^\circ\text{C}$, $I_F = 20\text{mA}$)

Item	Symbol	Conditions	Specifications			Unit	Note
			Min.	Typ.	Max.		
Contrast Ratio	CR	Viewing normal angle $\theta = 0^\circ$ $\phi = 0^\circ$ B/L On	300	500	--	--	(2),(4),(6)
Brightness	B		200	250	--	cd/m^2	
Response time	T_r		--	5	10	ms	(3)
	T_f	--	15	20	ms		
Chromaticity	Red	Rx	0.523	0.573	0.623	--	(2)(5)(6)
		Ry	0.30	0.350	0.40	--	
	Green	Gx	0.286	0.336	0.386	--	
		Gy	0.547	0.597	0.647	--	
	Blue	Bx	0.102	0.152	0.202	--	
		By	0.062	0.112	0.162	--	
	White	Wx	0.26	0.31	0.36	--	
Wy		0.28	0.33	0.38	--		
Viewing Angle	Hor.	θ_L	60	70	--	deg.	(1)
		θ_R	60	70	--		
	Ver.	Φ_T	40	50	--		
		Φ_B	50	60	--		
NTSC	--	--	--	50	--	%	
Uniformity	--	--	--	80	--	%	(7)

Note:

(1) Definition of viewing angle range

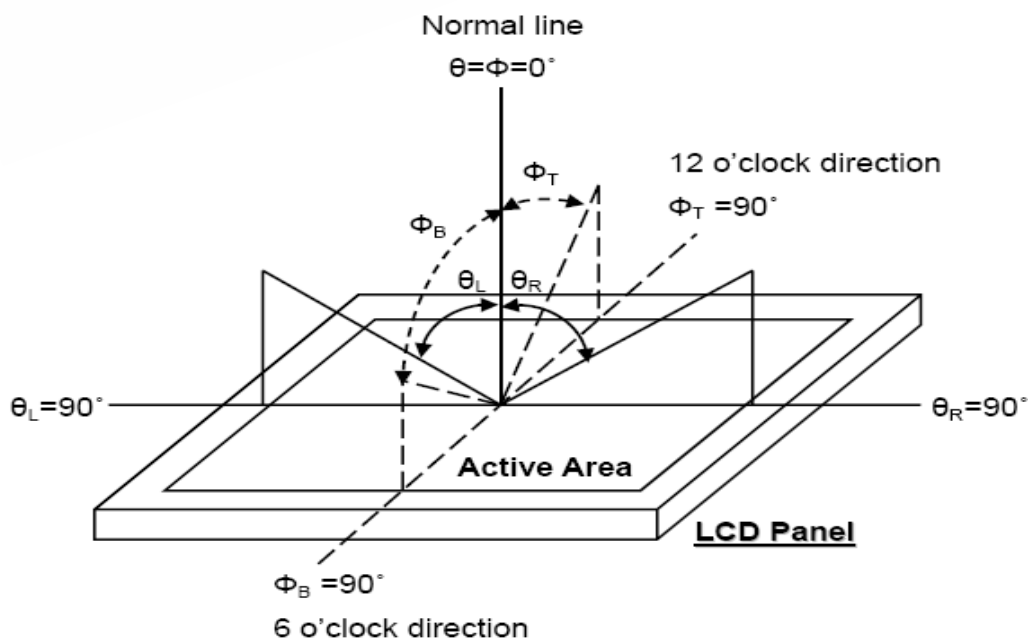

Fig. 8-1 Definition of viewing angle

(2) Test equipment setup:

After stabilizing and leaving the panel alone at a driven temperature for 10 minutes, the measurement should be executed. Measurement should be executed in a stable, windless, and dark room. Optical specifications are measured by Topcon BM-7 luminance meter 1.0° field of view at a distance of 50cm and normal direction.

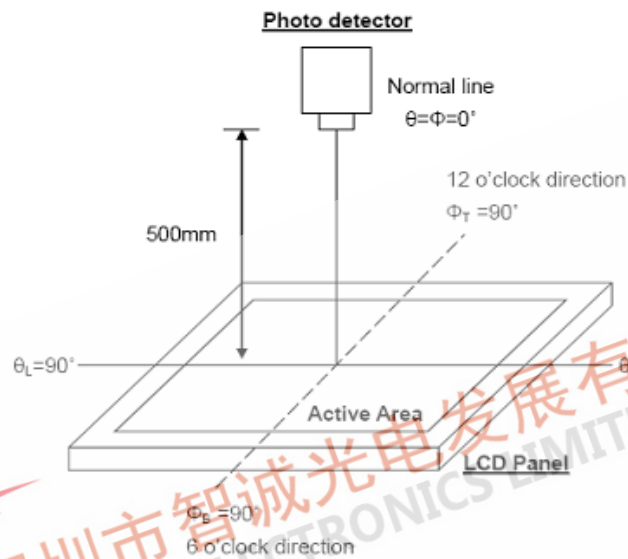

Fig. 8-2 Optical measurement system setup

(3) Definition of Response time:

The response time is defined as the LCD optical switching time interval between "White" state and "Black" state. Rise time, T_r , is the time between photo detector output intensity changed from 90% to 10%. And fall time, T_f , is the time between photo detector output intensity changed from 10% to 90%.

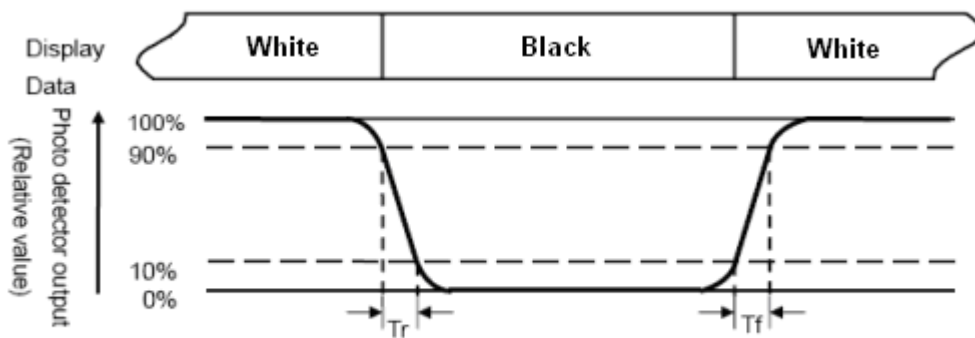

Fig. 8-3 Definition of response time

(4) Definition of contrast ratio:

The contrast ratio is defined as the following expression.

$$\text{Contrast ratio (CR)} = \frac{\text{Luminance measured when LCD on the "White" state}}{\text{Luminance measured when LCD on the "Black" state}}$$

(5) Definition of color chromaticity (CIE 1931)

Color coordinates measured at the center point of LCD

(6) Measured at the center area of the panel when all the input terminals of LCD panel are electrically opened.

$$(7) \text{ Uniformity (U)} = \frac{\text{Brightness (min)}}{\text{Brightness (max)}} \times 100\%$$

9. Interface Pin Connection

Pin	Symbol	I/O	Function	Remark
1	GND	G	Power Ground	
2	AVDD	P	Analog input voltage	
3	VCC	P	Digital input voltage	
4	R0	I	Red data input (LSB)	
5	R1	I	Red data input	
6	R2	I	Red data input	
7	R3	I	Red data input	
8	R4	I	Red data input	
9	R5	I	Red data input	
10	R6	I	Red data input	
11	R7	I	Red data input (MSB)	
12	G0	I	Green data input (LSB)	
13	G1	I	Green data input	
14	G2	I	Green data input	
15	G3	I	Green data input	
16	G4	I	Green data input	
17	G5	I	Green data input	
18	G6	I	Green data input	
19	G7	I	Green data input (MSB)	
20	B0	I	Blue data input (LSB)	
21	B1	I	Blue data input	
22	B2	I	Blue data input	
23	B3	I	Blue data input	
24	B4	I	Blue data input	
25	B5	I	Blue data input	
26	B6	I	Blue data input	
27	B7	I	Blue data input (MSB)	
28	CLKIN	I	Dot clock input	
29	DEN	I	Data enable signal	
30	HSD	I	HSYNC signal	
31	VSD	I	VSYNC signal	
32	MODE	I	H: DE mode (Default) L: SYNC mode	

33	NC	I	No connect (please leave it open)	
34	NC	I	No connect (please leave it open)	
35	NC	-	No connect (please leave it open)	
36	VCC	P	Digital input voltage	
37	NC	-	No connect (please leave it open)	
38	GND	G	Power Ground	
39	GND	G	Power Ground	
40	AVDD	P	Analog input voltage	
41	VCOM	P	VCOM DC input	
42	DITH	I	Dithering function setting H: Disable dithering function L: Enable dithering function	
43	NC	-	No connect (please leave it open)	
44	VCOM out	O	connect a capacitor	
45	NC		No connect (please leave it open)	
46	NC		No connect (please leave it open)	
47	NC		No connect (please leave it open)	
48	NC		No connect (please leave it open)	
49	NC		No connect (please leave it open)	
50	NC		No connect (please leave it open)	
51	NC		No connect (please leave it open)	
52	NC		No connect (please leave it open)	
53	NC		No connect (please leave it open)	
54	NC		No connect (please leave it open)	
55	NC	-	No connect (please leave it open)	
56	VGH	P	TFT turn on voltage	
57	VCC	P	Digital input voltage	
58	VGL	P	TFT turn off voltage	
59	GND	G	Power Ground	
60	NC	-	No connect (please leave it open)	

Note:

(1) Suggested connector: MT-FP160N-2FR (UJU) or any equivalent

10. Block Diagram

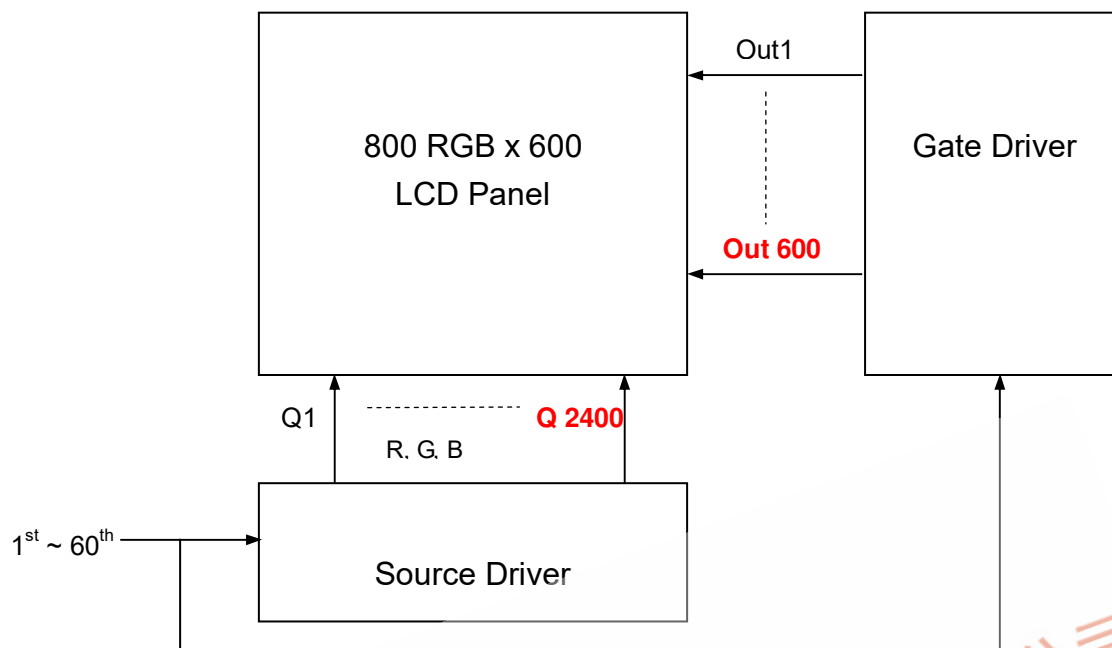

11. Quality Assurance

No.	Test Items	Test Condition	Note
1	High Temperature Storage Test	Ta=70°C Dry 240h	
2	Low Temperature Storage Test	Ta=-20°C Dry 240h	
3	High Temperature Operation Test	Ta=60°C Dry 240h	
4	Low Temperature Operation Test	Ta=-10°C Dry 240h	
5	High Temperature and High Humidity Operation Test	Ta=50°C 80%RH 240h	
6	Electro Static Discharge Test	Panel surface / top case Contact / Air : ±6KV / ±15KV , 150pF , 330Ω	Non-operating
7	Shock Test (non-operating)	Shock Level : 100G Waveform: Half Sinusoidal wave Shock Time : 6ms 3 Axis for all six faces/ each	
8	Vibration Test (non-operating)	Random Vibration 0.015 G ² /Hz from 5-200Hz -6dB/ octave from 200-500Hz	
9	Thermal Shock Test	-10°C(0.5Hr) ~ +60°C(0.5Hr) for 100 cycles	

Note:

(1) All the cosmetic specifications are judged before the reliability stress.

12. Outline Drawing

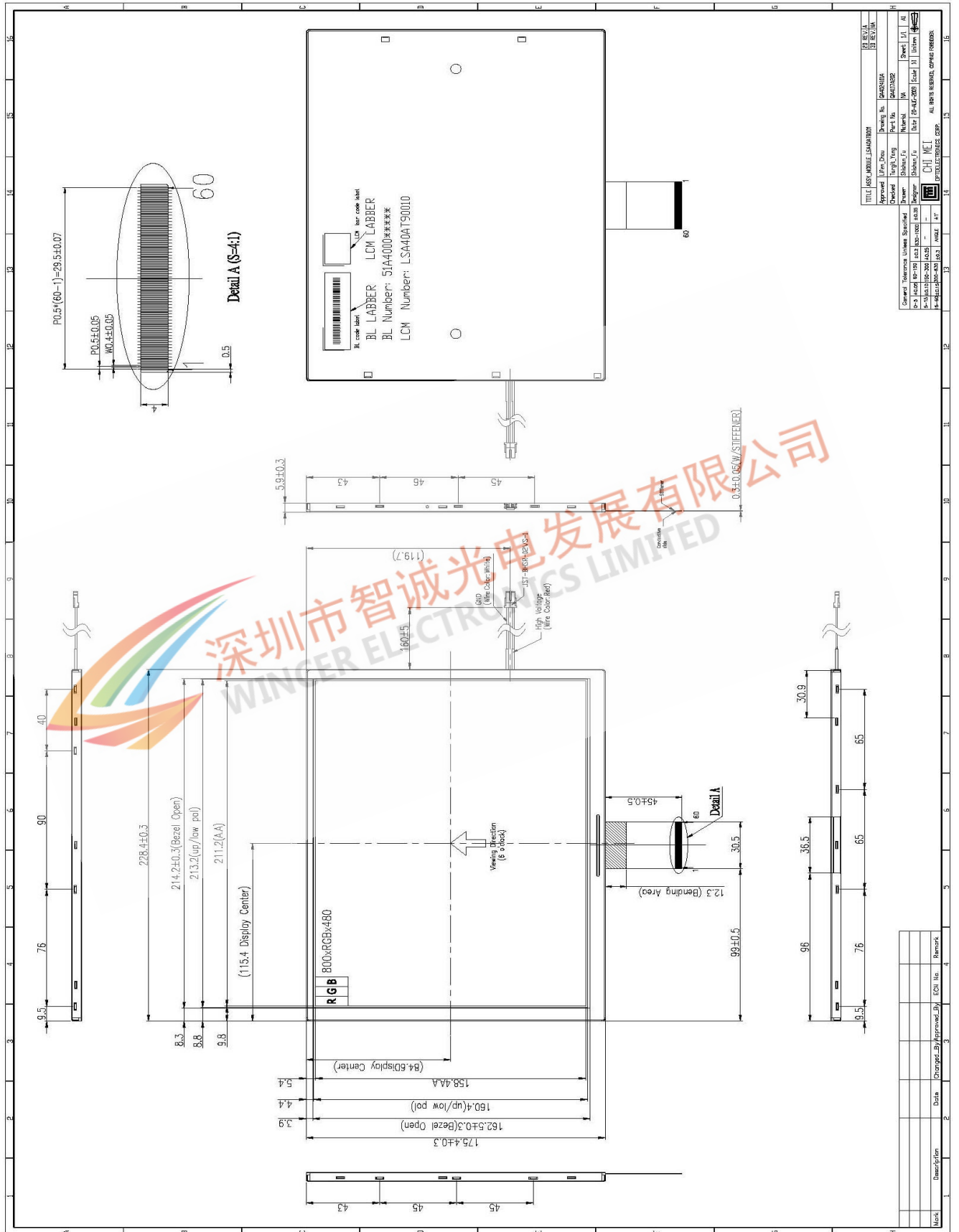

13. Package Form

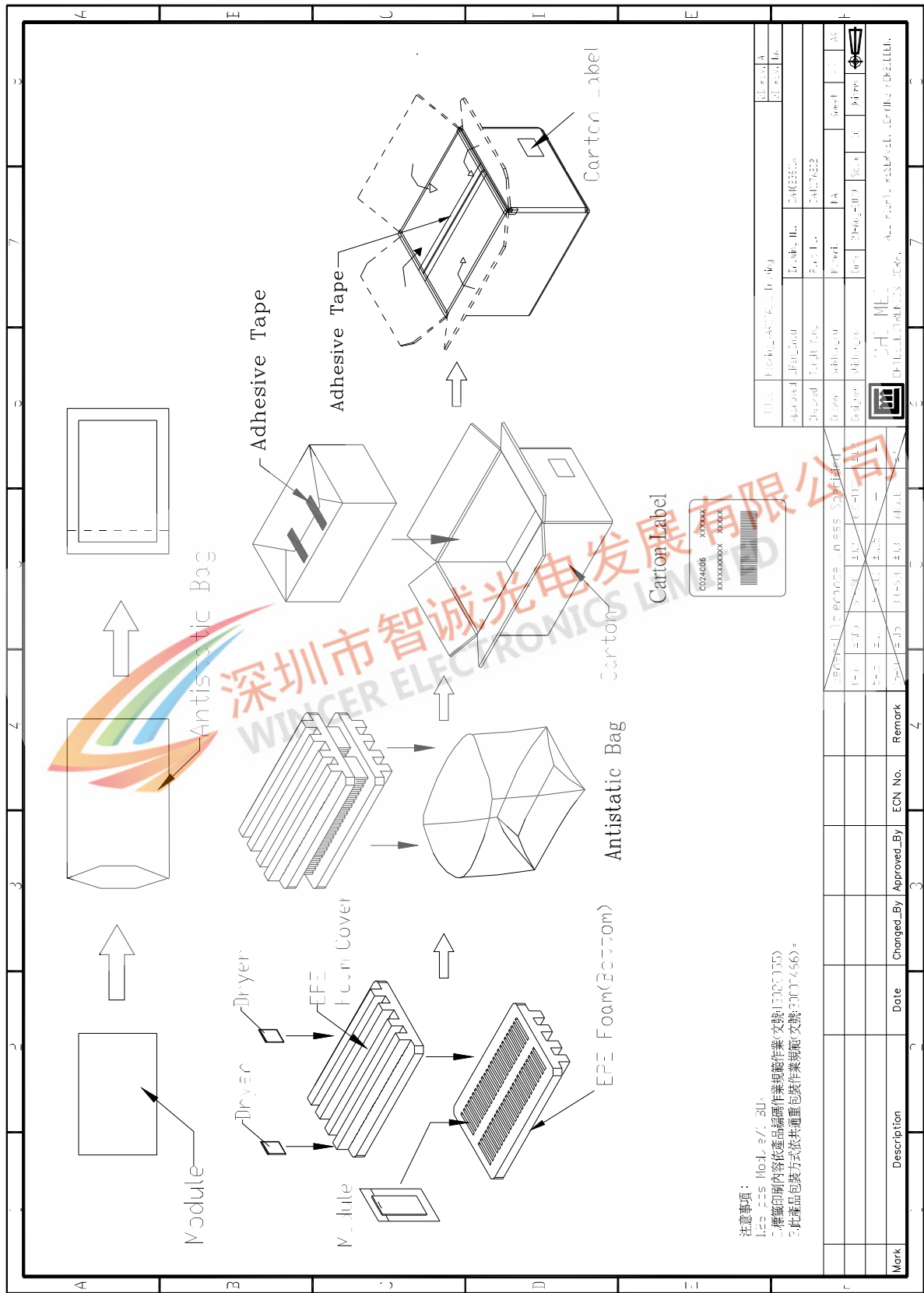

注意事項：
 1. 本產品 Model: BU
 2. 標籤印刷內容與產品標作業規範作業(時:300010)
 3. 此產品包裝方式依共通重包裝作業規範(文號:3001456)

Title	Product Assembly Drawing	Drawn By	CAIYONG	Checked By	LIANGYU
Released	2012/01/01	Part No.	0107022	Scale	1:1
Drawn	2012/01/01	Part No.	0107022	Scale	1:1
Released	2012/01/01	Part No.	0107022	Scale	1:1

Mark	Description	Date	Changed By	Approved By	ECN No.	Remark

14. Precautions

Please pay attention to the following when you use this TFT-LCD module.

14.1 Mounting Precautions

- (1) You must mount a module using arranged in four corners or four sides.
- (2) You should consider the mounting structure so that uneven force (ex. Twisted stress) is not applied to the module.
And the case on which a module is mounted should have sufficient strength so that external force is not transmitted directly to the module.
- (3) Please attach a transparent protective plate to the surface in order to protect the polarizer. Transparent protective plate should have sufficient strength in order to the resist external force.
- (4) You should adopt radiation structure to satisfy the temperature specification.
- (5) Acetic acid type and chlorine type materials for the cover case are not describe because the former generates corrosive gas of attacking the polarizer at high temperature and the latter causes circuit break by electro-chemical reaction.
- (6) Do not touch, push or rub the exposed polarizers with glass, tweezers or anything harder than HB pencil lead. And please do not rub with dust clothes with chemical treatment.
Do not touch the surface of polarizer for bare hand or greasy cloth. (Some cosmetics are determined to the polarizer)
- (7) When the surface becomes dusty, please wipe gently with adsorbent cotton or other soft materials like chamois soaks with petroleum benzene. Normal-hexane is recommended for cleaning the adhesives used to attach front / rear polarizers. Do not use acetone, toluene and alcohol because they cause chemical damage to the polarizer.
- (8) Wipe off saliva or water drops as soon as possible. Their long time contact with polarizer causes deformations and color fading.
- (9) Do not open the case because inside circuits do not have sufficient strength.

14.2 Operating Precautions

- (1) The spike noise causes the mis-operation of circuits. It should be lower than following voltage : $V=\pm 200\text{mV}$ (Over and under shoot voltage)
- (2) Response time depends on the temperature. (In lower temperature, it becomes longer.)
- (3) Brightness depends on the temperature. (In lower temperature, it becomes lower)
And in lower temperature, response time (required time that brightness is stable after turned on) becomes longer.
- (4) Be careful for condensation at sudden temperature change. Condensation makes damage to polarizer or electrical contacted parts. And after fading condensation, smear or spot will occur.
- (5) When fixed patterns are displayed for a long time, remnant image is likely to occur.
- (6) Module has high frequency circuits. Sufficient suppression to the electromagnetic interference

shall be done by system manufacturers. Grounding and shielding methods may be important to minimize the interference.

14.3 Electrostatic Discharge Control

Since a module is composed of electronic circuits, it is not strong to electrostatic discharge. Make certain that treatment persons are connected to ground through wristband etc. And don't touch interface pin directly.

14.4 Precautions for Strong Light Exposure

Strong light exposure causes degradation of polarizer and color filter.

14.5 Storage

When storing modules as spares for a long time, the following precautions are necessary.

- (1) Store them in a dark place. Do not expose the module to sunlight or fluorescent light. Keep the temperature between 5°C and 35°C at normal humidity.
- (2) The polarizer surface should not come in contact with any other object. It is recommended that they be stored in the container in which they were shipped.

14.6 Handling Precautions for Protection Film

(1) When the protection film is peeled off, static electricity is generated between the film and polarizer. This should be peeled off slowly and carefully by people who are electrically grounded and with well ion-blown equipment or in such a condition, etc.

(2) The protection film is attached to the polarizer with a small amount of glue. Is apt to remain on the polarizer. Please carefully peel off the protection film without rubbing it against the polarizer.

(3) When the module with protection film attached is stored for a long time, sometimes there remains a very small amount of glue still on the polarizer after the protection film is peeled off.

(4) You can remove the glue easily. When the glue remains on the polarizer surface or its vestige is recognized, please wipe them off with absorbent cotton waste or other soft material like chamois soaked with normal-hexane.