

# LCD MODULE SPECIFICATION

**Customer:** \_\_\_\_\_

Model Name : ZT101IP35025-17

**Date:** 2017/11/19

**Version:** 01

**Preliminary Specification**

**Final Specification**

For Customer's Acceptance

Approved by	Comment
 深圳市智诚光电发展有限公司 WINCER ELECTRONICS LIMITED	

Approved by	Reviewed by	Prepared by
Jreey	Sally	Wendy

Record of Revision

Version	Revise Date	Page	Content
Pre-Spec.01	2017/11/19		Initial Release

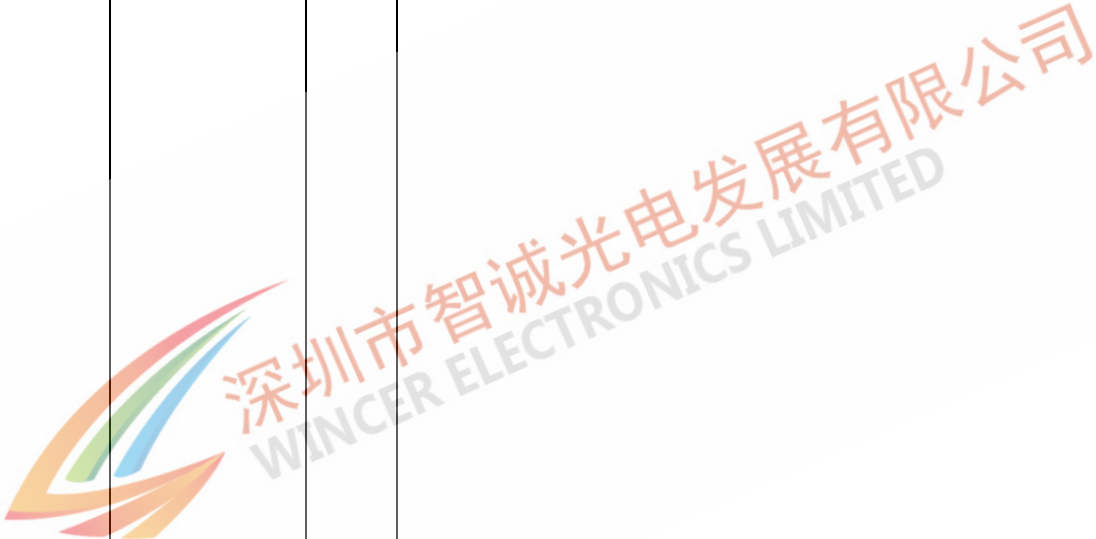

# Contents

1. General Specifications .....	1
2. Pin Assignment .....	2
3. Operation Specifications .....	4
3.1. Absolute Maximum Ratings .....	4
3.2. Typical Operation Conditions .....	6
3.3. Power Sequence .....	7
3.4. LVDS Signal Timing Characteristics .....	8
3.4.1. AC Electrical Characteristics .....	8
3.4.2. Timing Table .....	9
3.4.3. LVDS Data Input Format .....	10
4. Optical Specifications .....	11
5. Reliability Test Items .....	15
6. General Precautions .....	16
6.1. Safety .....	16
6.2. Handling .....	16
6.3. Static Electricity .....	16
6.4. Storage .....	16
6.5. Cleaning .....	16
7. Mechanical Drawing .....	17
8. Package Drawing .....	18
8.1. Packaging Material Table .....	18
8.2. Packaging Quantity .....	18
8.3. Packaging Drawing .....	18

深圳市智诚光电发展有限公司  
WINNER ELECTRONICS LIMITED

# 1. General Specifications

No.	Item	Specification	Remark
1	LCD size	10.1 inch(Diagonal)	
2	Driver element	a-Si TFT active matrix	
3	Resolution	1280 × 3(RGB) × 800	
4	Display mode	Normally Black, Transmissive	
5	Dot pitch	0.0565(W) × 0.1695(H) mm	
6	Active area	216.96(W) × 135.60(H) mm	
7	Module size	229.46(W) × 149.1(H) × 2.50(D) mm	Note 1
8	Surface treatment	Hard Coating (3H)	
9	Color arrangement	RGB-stripe	
10	Interface	LVDS	
11	Backlight power consumption	(1.86 W)(Typ.)	
12	Panel power consumption	(1W)(Typ.)	Note 2
13	Weight	TBD(Typ.)	

Note 1: Refer to Mechanical Drawing.

Note 2: Including T-con Board power consumption

## 2. Pin Assignment

A 40pin connector is used for the module electronics interface. The recommended model is F62240-H1210A manufactured by Vigorconn.

Pin No.	Symbol	I/O	Function	Remark
1	VCOM	P	Common Voltage	
2	VDD	P	Power Supply	
3	VDD	P	Power Supply	
4	NC	---	No connection	
5	NC	---	No connection	
6	NC	---	No connection	
7	GND	P	Ground	
8	Rxin0-	I	-LVDS Differential Data Input	R0-R5, G0
9	Rxin0+	I	+LVDS Differential Data Input	
10	GND	P	Ground	
11	Rxin1-	I	-LVDS Differential Data Input	G1~G5, B0,B1
12	Rxin1+	I	+LVDS Differential Data Input	
13	GND	P	Ground	
14	Rxin2-	I	-LVDS Differential Data Input	B2-B5,HS,VS, DE
15	Rxin2+	I	+LVDS Differential Data Input	
16	GND	P	Ground	
17	RxCLK-	I	-LVDS Differential Clock Input	LVDS CLK
18	RxCLK+	I	+LVDS Differential Clock Input	
19	GND	P	Ground	
20	Rxin3-	I	-LVDS Differential Data Input	R6, R7, G6, G7, B6, B7
21	Rxin3+	I	+LVDS Differential Data Input	
22	GND	P	Ground	
23	NC	---	No connection	
24	NC	---	No connection	
25	GND	P	Ground	
26	NC	---	No connection	

27	LED_PWM	O	CABC controller signal output for backlight	Note2
28	NC	---	No connection	
29	AVDD	P	Power for Analog Circuit	
30	GND	P	Ground	
31	NC	P		
32	NC	P		
33	LED-	p	LED Anode	
34	LED-	p	LED Anode	
35	VGL	P	Gate OFF Voltage	
36	NC	---	No connection	
37	CABC_EN	I	CABC Enable Input	Note1
38	VGH	P	Gate ON Voltage	
39	LED+	P	LED Anode	
40	LED+	P	LED Anode	

I: input, O: output, P: Power

Note1: The setting of CABC function are as follows.

Pin	Enable	Disable
CABC_EN	High Voltage	Low Voltage or open

Note2: LED\_PWM is used to adjust backlight brightness.

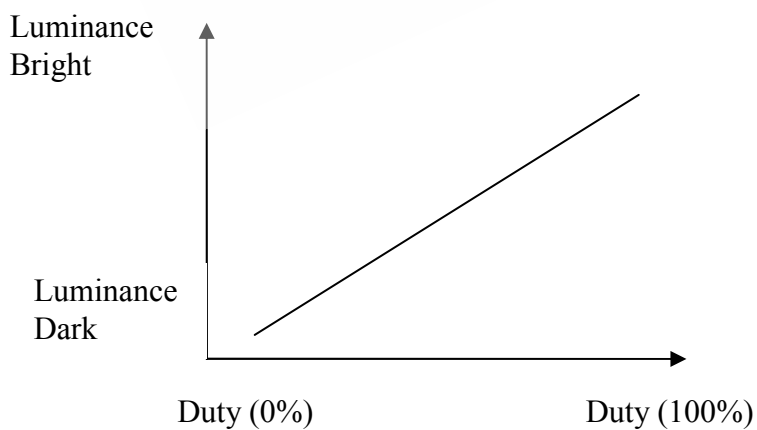

### 3. Operation Specifications

#### 3.1. Absolute Maximum Ratings

(Note 1)

Item	Symbol	Values		Unit	Remark
		Min.	Max.		
Power voltage	VDD	-0.3	3.9	V	
	AVDD	-0.3	14	V	
	V <sub>GH</sub>	-0.3	42.0	V	
	V <sub>GL</sub>	-19	0.3	V	
	V <sub>GH</sub> -V <sub>GL</sub>	12	40.0	V	
Operation Temperature	T <sub>OP</sub>	-10	50	°C	
Storage Temperature	T <sub>ST</sub>	-20	60	°C	
LED Reverse Voltage	V <sub>F</sub>	2.7	3.1	V	I <sub>F</sub> =20mA
LED Forward Current	I <sub>R</sub>	---	50	mA	V <sub>R</sub> =5V

Note 1: The absolute maximum rating values of this product are not allowed to be exceeded at any times. Should a module be used with any of the absolute maximum ratings exceeded, the characteristics of the module may not be recovered, or in an extreme case, the module may be permanently destroyed.

### 3.1.1. Current Consumption

Item	Symbol	Values			Unit	Remark
		Min.	Typ.	Max.		
Current for Driver	$I_{GH}$	-	STB	STB	mA	$V_{GH} = 22V$
	$I_{GL}$	-	STB	STB	mA	$V_{GL} = -7V$
	$I_{V_{DD}}$	-	STB	STB	mA	$V_{DD} = 2.5V$
	$I_{AV_{DD}}$	-	STB	STB	mA	$AV_{DD} = 8.2V$

### 3.1.2. Backlight Driving Conditions

Item	Symbol	Values			Unit	Remark
		Min.	Typ.	Max.		
Voltage for LED backlight	$V_L$	9.0	(9.9)	10.5	V	Note 1
Current for LED backlight	$I_L$	-	260	-	mA	
LED life time	-	20000	25000	30000	Hr	Note 2

Note 1: The LED Supply Voltage is defined by the number of LED at  $T_a = 25^\circ C$  and  $I_L = 260mA$ .

Note 2: The "LED life time" is defined as the module brightness decrease to 50% original brightness at  $T_a = 25^\circ C$  and  $I_L = 260mA$ . The LED lifetime could be decreased if operating  $I_L$  is larger than 260mA.



### 3.2. Typical Operation Conditions

( Note 1)

Item	Symbol	Values			Unit	Remark
		Min.	Typ.	Max.		
Power voltage	VDD	2.3	2.5	2.7	V	Note 2
	AVDD	8.0	8.2	8.4	V	
	V <sub>GH</sub>	21.7	22	22.3	V	
	V <sub>GL</sub>	-7.3	-7	-6.7	V	
Input signal voltage	VCOM	3.0	3.3	3.6	V	Note 4
Input logic high voltage	V <sub>IH</sub>	0.8 VDD	-	3.6	V	Note 3
Input logic low voltage	V <sub>IL</sub>	0	-	0.2 DV <sub>DD</sub>	V	

Note 1: Be sure to apply VDD and V<sub>GL</sub> to the LCD first, and then apply V<sub>GH</sub>.

Note 2: VDD setting should match the signals output voltage (refer to Note 3) of customer's system board.

Note 4: Typical VCOM is only a reference value, it must be optimized according to each LCM. Be sure to use VR.

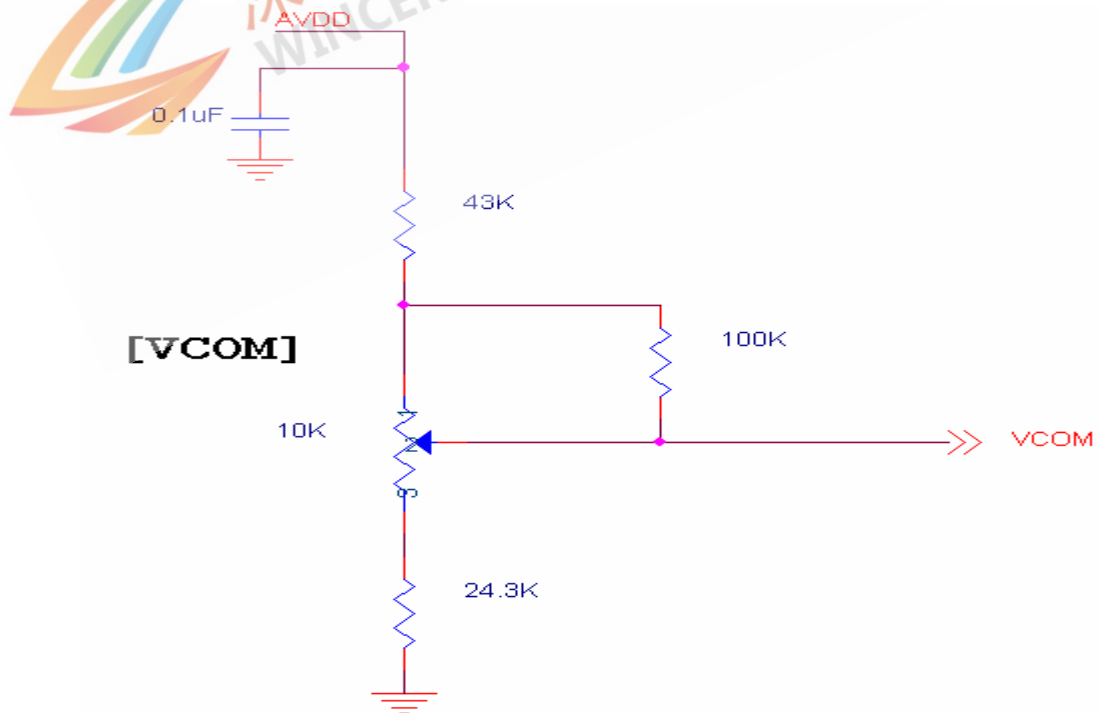

### 3.3. Power Sequence

#### a. Power on:

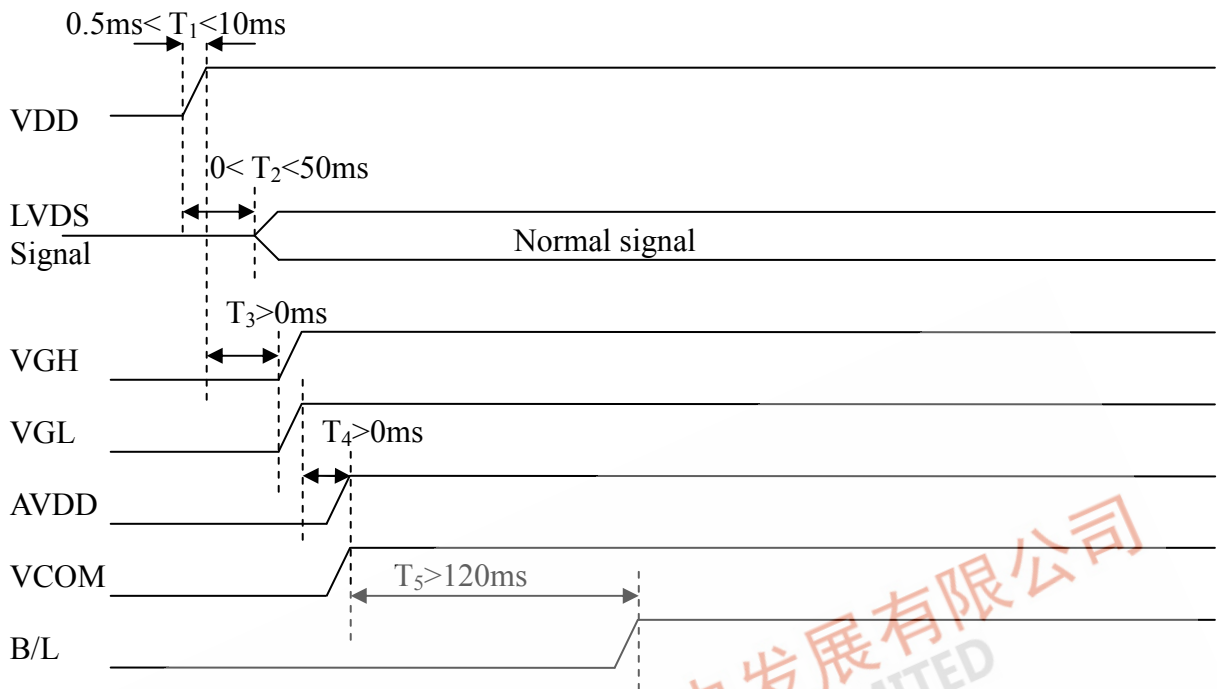

#### b. Power off:

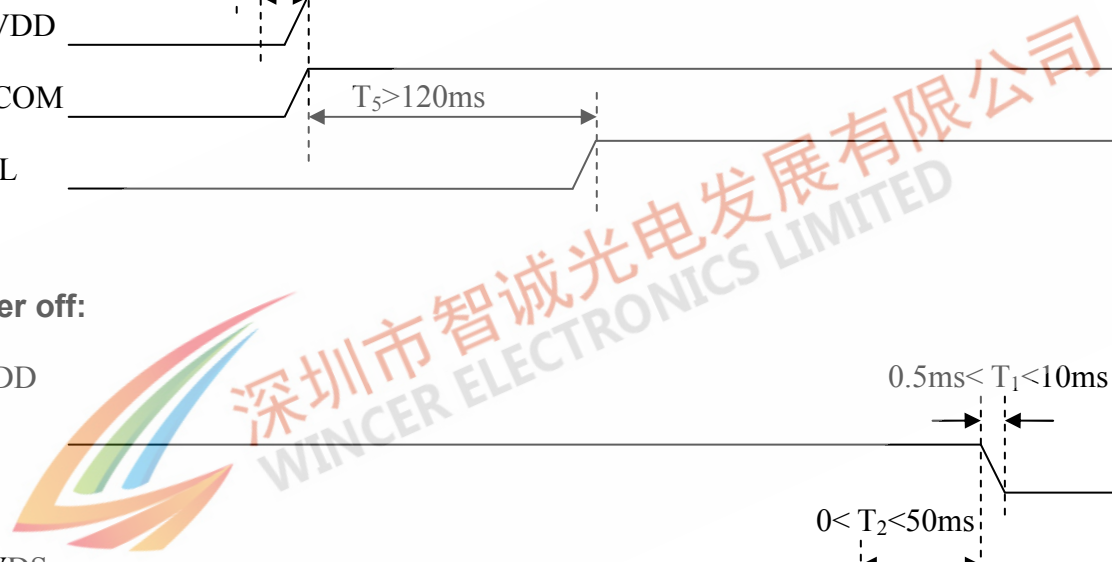
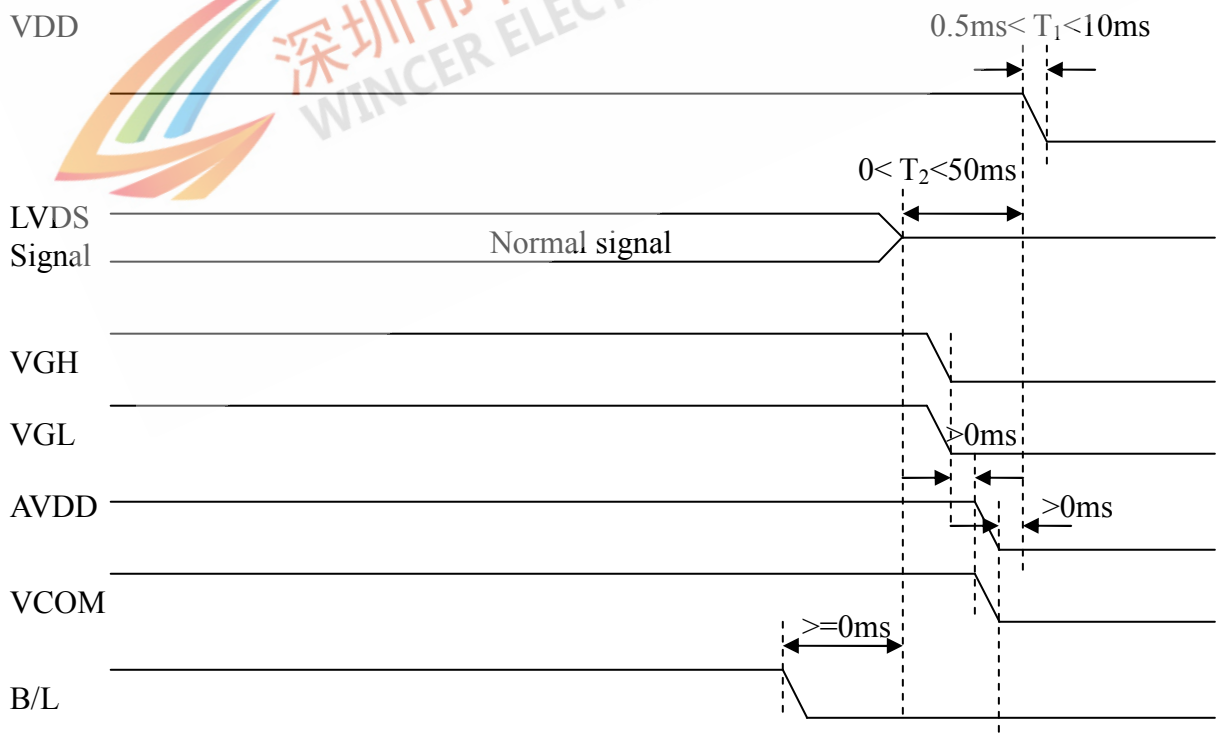

### 3.4. LVDS Signal Timing Characteristics

#### 3.4.1. AC Electrical Characteristics

Parameter	Symbol	Values			Unit	Remark
		Min.	Typ.	Max.		
LVDS Differential input high Threshold voltage	$R_{xVTH}$	-	-	+100	mV	$R_{xVCM}=1.2V$
LVDS Differential input low Threshold voltage	$R_{xVTL}$	-100	-	-	mV	
LVDS Differential input common mode voltage	$R_{xVCM}$	0.7	-	1.6	V	
LVDS Differential voltage	$ V_{ID} $	100	-	600	mV	

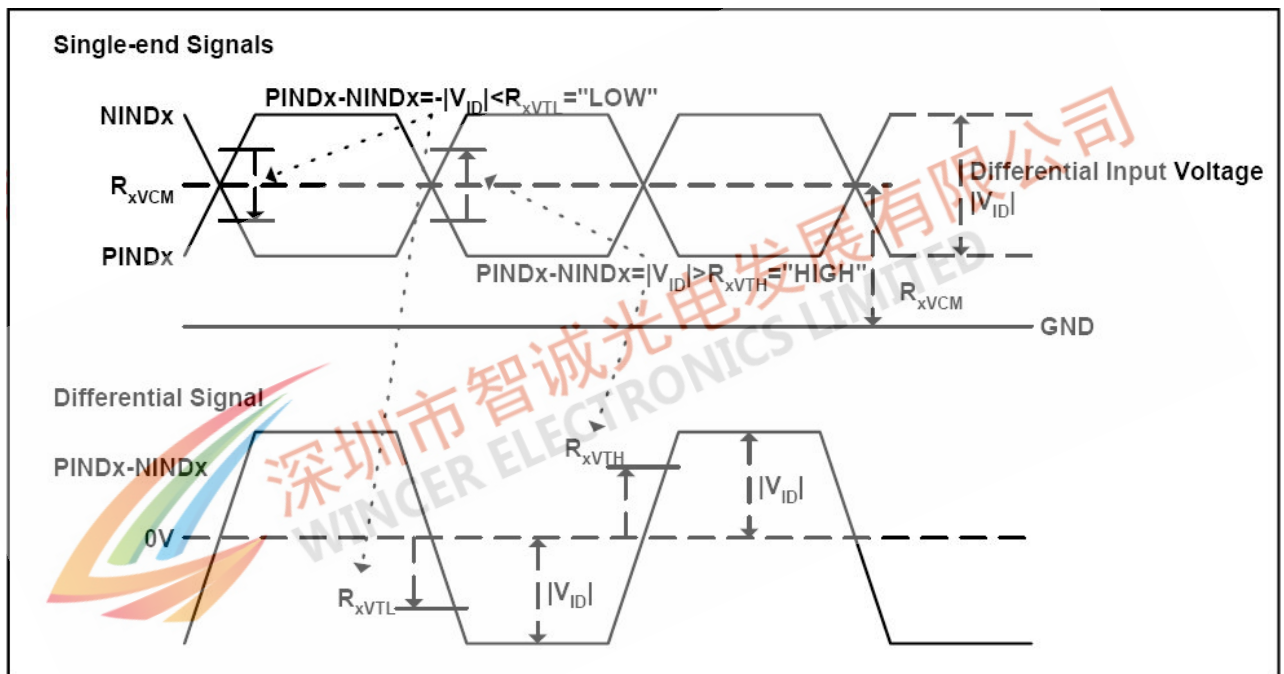

## 3.4.2. Timing Table

Item	Symbol	Values			Unit	Remark
		Min.	Typ.	Max.		
Clock Frequency	1/Tc	(68.9)	71.1	(73.4)	MHz	Frame rate =60Hz
Horizontal display area	t <sub>HD</sub>	1280			Tc	
HS period time	t <sub>H</sub>	(1410)	1440	(1470)	Tc	
HS Width +Back Porch +Front Porch	t <sub>HW</sub> + t <sub>HBP</sub> +t <sub>HFP</sub>	(60)	160	(190)	Tc	
Vertical display area	t <sub>VD</sub>	800			t <sub>H</sub>	
VS period time	t <sub>v</sub>	(815)	823	(833)	t <sub>H</sub>	
VS Width +Back Porch +Front Porch	t <sub>VW</sub> + t <sub>VBP</sub> +t <sub>VFP</sub>	(15)	23	(33)	t <sub>H</sub>	

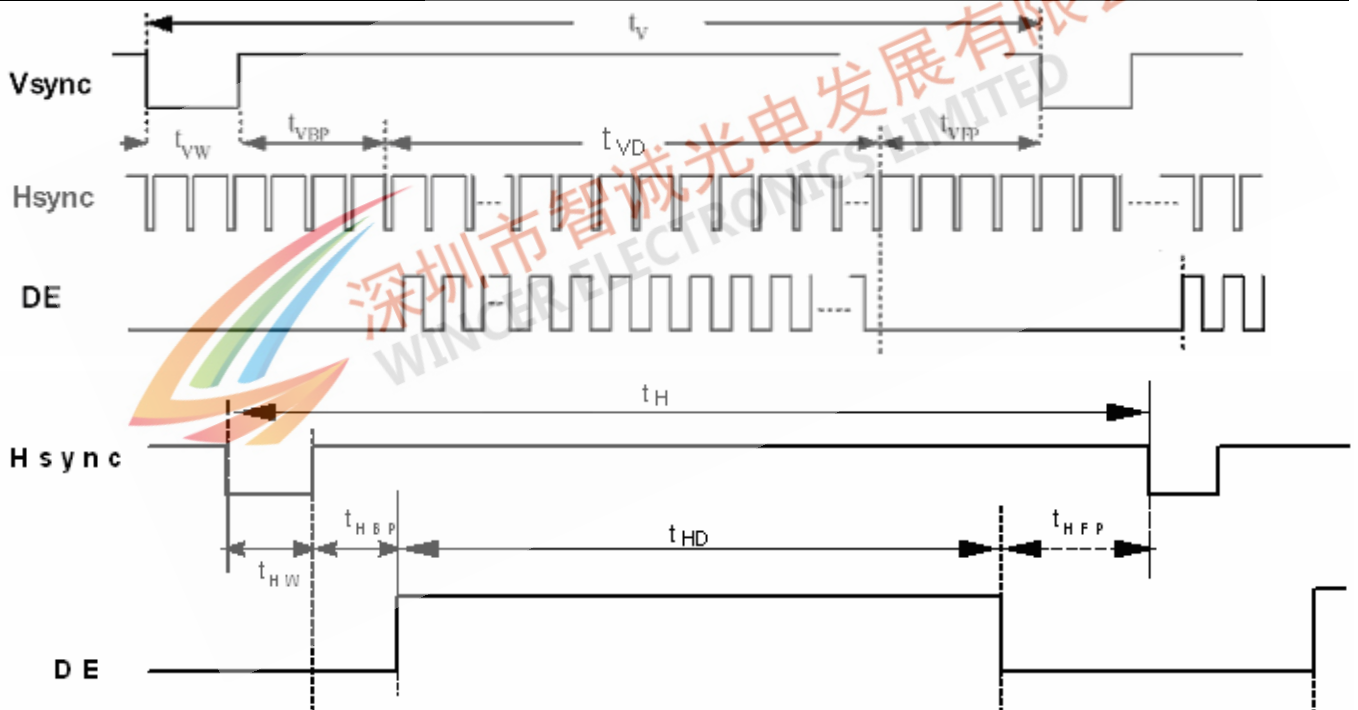

### 3.4.3. LVDS Data Input Format

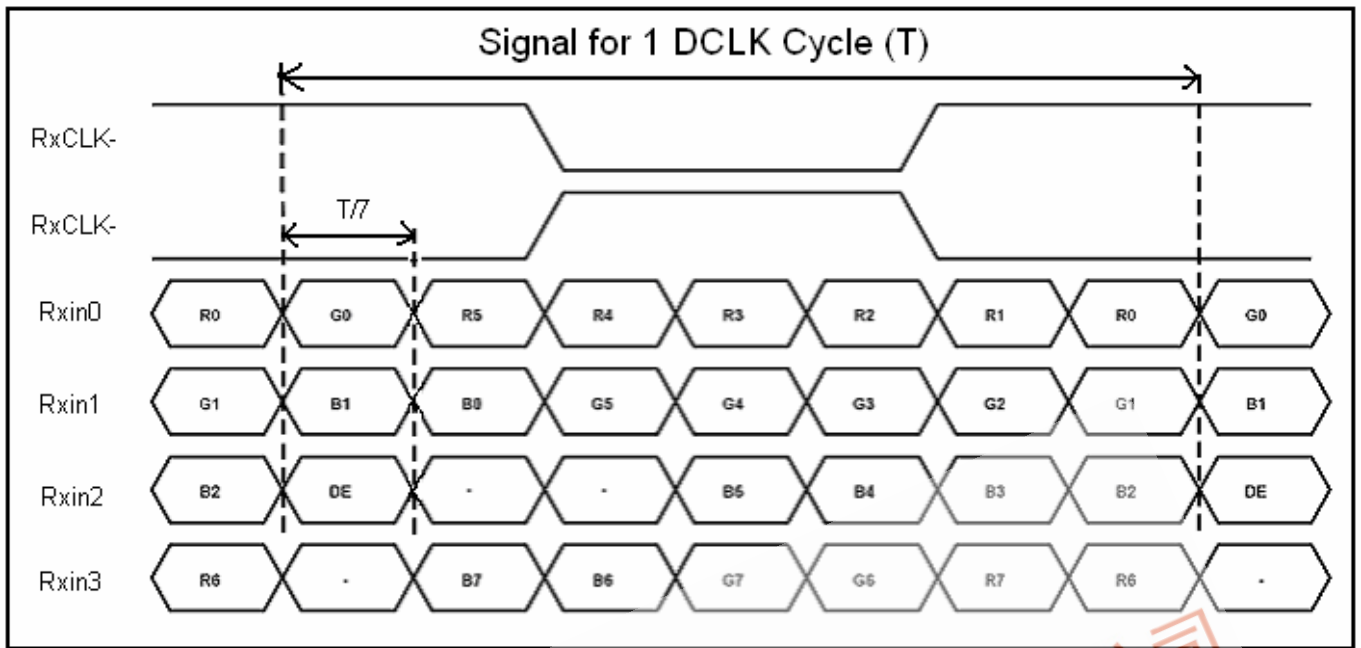

## 4. Optical Specifications

Item	Symbol	Condition	Values			Unit	Remark
			Min.	Typ.	Max.		
Viewing angle (CR≥ 10)	$\theta_L$	$\Phi=180^\circ$ (9 o'clock)	75	85	-	degree	Note 1
	$\theta_R$	$\Phi=0^\circ$ (3 o'clock)	75	85	-		
	$\theta_T$	$\Phi=90^\circ$ (12 o'clock)	75	85	-		
	$\theta_B$	$\Phi=270^\circ$ (6 o'clock)	75	85	-		
Response time	$T_{ON}$	Normal $\theta=\Phi=0^\circ$	-	10	20	msec	Note 3
	$T_{OFF}$		-	15	30	msec	Note 3
Contrast ratio	CR		600	800	-	-	Note 4
Color chromaticity	$W_x$		0.26	0.31	0.36	-	Note 2
	$W_y$		0.28	0.33	0.38	-	Note 5 Note 6
Luminance	$L$		350	380	-	cd/m <sup>2</sup>	Note 6
Luminance uniformity	$Y_U$		75	80	-	%	Note 7

Test Conditions:

1.  $DV_{DD}=3.3V$ ,  $I_L=260mA$  (Backlight current), the ambient temperature is  $25^\circ C$ ..
2. The test systems refer to Note 2.

Note 1: Definition of viewing angle range

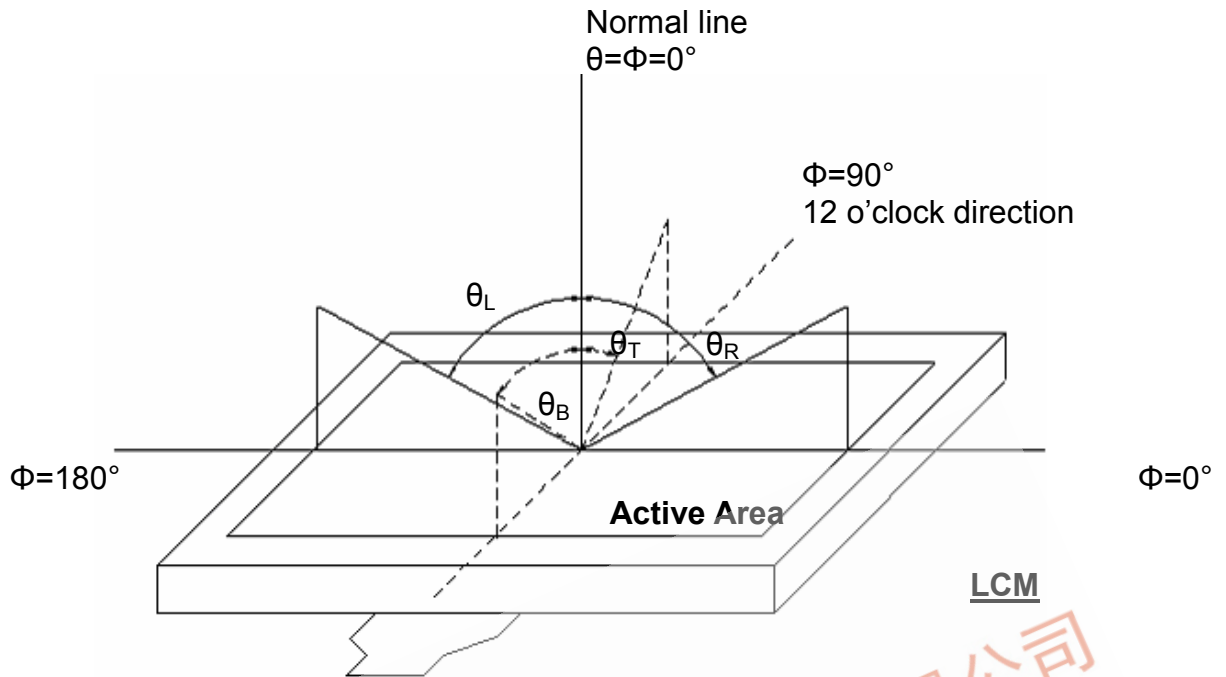

Fig. 4-1 Definition of viewing angle

Note 2: Definition of optical measurement system.

The optical characteristics should be measured in dark room. After 30 minutes operation, the optical properties are measured at the center point of the LCD screen. (Viewing angle is measured by ELDIM-EZ contrast/Height :1.2mm, Response time is measured by Photo detector TOPCON BM-7, other items are measured by BM-5A/ Field of view:  $1^\circ$  /Height: 500mm.)

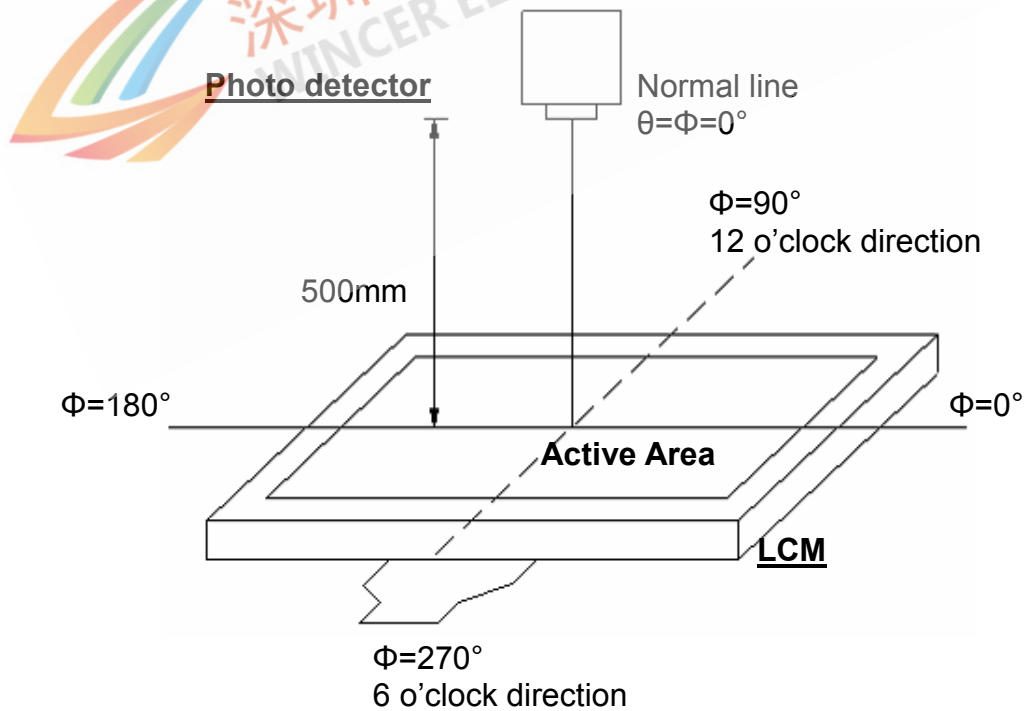

Fig. 4-2 Optical measurement system setup

Note 3: Definition of Response time

The response time is defined as the LCD optical switching time interval between "White" state and "Black" state. Rise time ( $T_{ON}$ ) is the time between photo detector output intensity changed from 90% to 10%. And fall time ( $T_{OFF}$ ) is the time between photo detector output intensity changed from 10% to 90%.

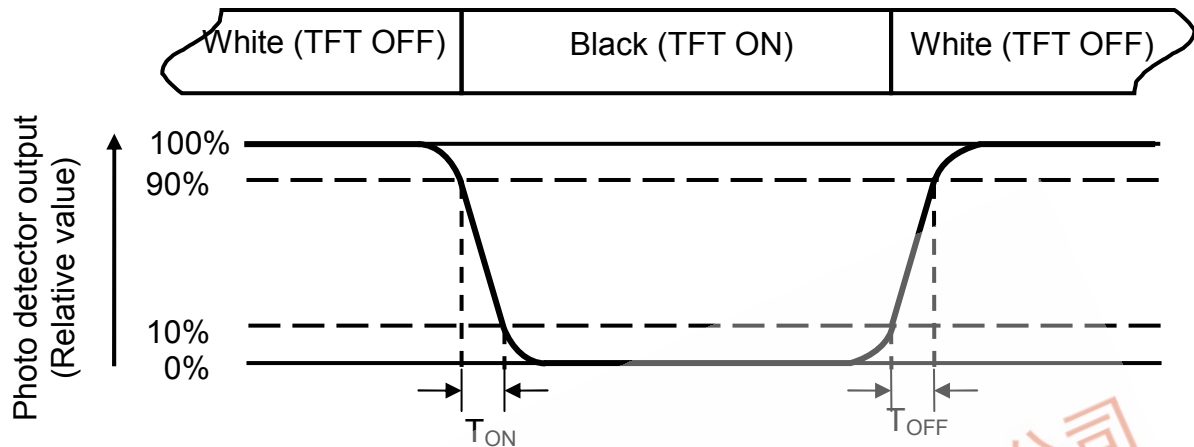

Fig. 4-3 Definition of response time

Note 4: Definition of contrast ratio

$$\text{Contrast ratio (CR)} = \frac{\text{Luminance measured when LCD on the "White" state}}{\text{Luminance measured when LCD on the "Black" state}}$$

Note 5: Definition of color chromaticity (CIE1931)

Color coordinates measured at center point of LCD.

Note 6: All input terminals LCD panel must be ground while measuring the center area of the panel. The LED driving condition is  $I_L=240\text{mA}$ .



Note 7: Definition of Luminance Uniformity

Measure the luminance of gray level 63 at 9 points

$$\delta W_{9p} = \frac{\text{Minimum [L (1)+ L (6)+ L (7)+ L (8)+ L (9)+ L (10)+ L (11) +L (12) +L (13)]}}{\text{Maximum [L (1)+ L (6)+ L (7)+ L (8)+ L (9)+ L (10)+ L (11) +L (12) +L (13)]}} \times 100\%$$

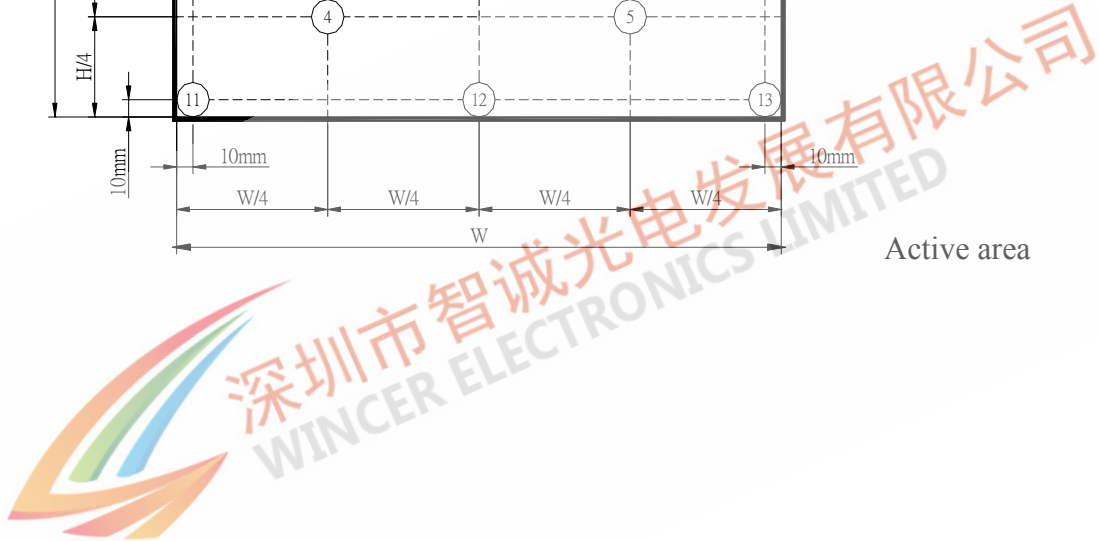
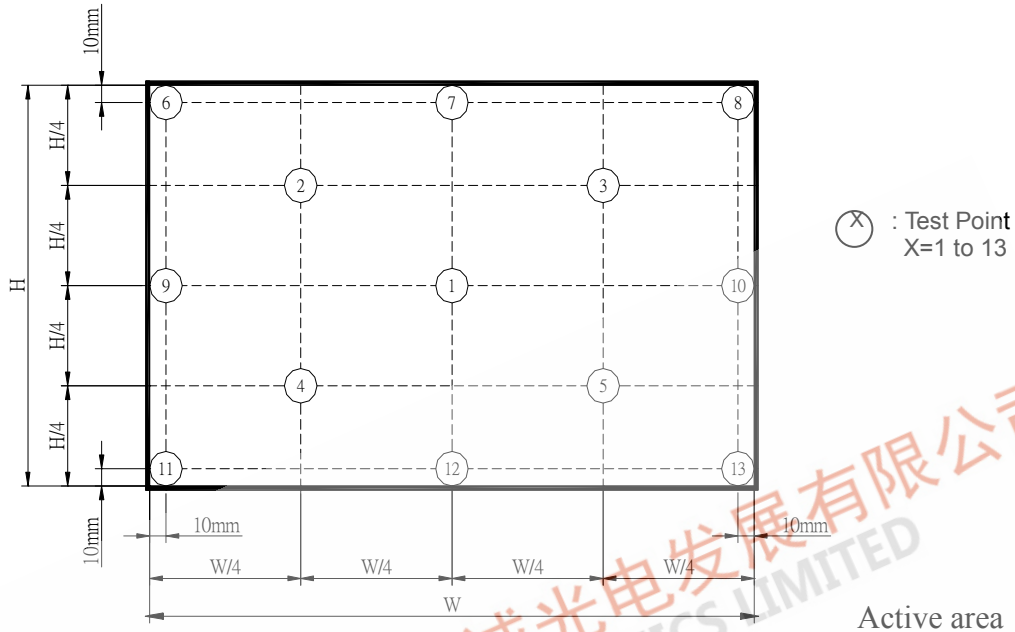

## 5. Reliability Test Items

(Note3)

Item	Test Conditions	Remark
High Temperature Storage	Ta = 60°C                      120hrs	Note 1, Note 4
Low Temperature Storage	Ta = -20°C                      120hrs	Note 1, Note 4
High Temperature Operation	Ts = 50°C                      120hrs	Note 2, Note 4
Low Temperature Operation	Ta = -10°C                      120hrs	Note 1, Note 4
Operate at High Temperature and Humidity	+40°C, 90%RH                      120hrs	Note 4
Thermal Shock	-10°C/30 min ~ +50°C/30 min for a total 100 cycles, Start with cold temperature and end with high temperature.	Note 4
Vibration Test	Frequency range:10~55Hz Stroke:1.5mm Sweep:10Hz~55Hz~10Hz 2 hours for each direction of X. Y. Z. (6 hours for total)	
Mechanical Shock	100G 6ms,±X, ±Y, ±Z 3 times for each direction	
Package Vibration Test	Random Vibration : ISTA-3A 1Hz~200Hz,Grms=0.53 Half hours for direction of Z.	
Package Drop Test	Height:60 cm 1 corner, 3 edges, 6 surfaces	
Electro Static Discharge	± 2KV, Human Body Mode, 100pF/1500Ω	

Note 1: Ta is the ambient temperature of samples.

Note 2: Ts is the temperature of panel's surface.

Note 3: In the standard condition, there shall be no practical problem that may affect the display function. After the reliability test, the product only guarantees operation, but don't guarantee all of the cosmetic specification.

Note 4: Before cosmetic and function test, the product must have enough recovery time, at least 2 hours at room temperature.

## 6. General Precautions

### 6.1. Safety

Liquid crystal is poisonous. Do not put it in your mouth. If liquid crystal touches your skin or clothes, wash it off immediately by using soap and water.

### 6.2. Handling

1. The LCD panel is plate glass. Do not subject the panel to mechanical shock or to excessive force on its surface.
2. The polarizer attached to the display is easily damaged. Please handle it carefully to avoid scratch or other damages.
3. To avoid contamination on the display surface, do not touch the module surface with bare hands.
4. Keep a space so that the LCD panels do not touch other components.
5. Put cover board such as acrylic board on the surface of LCD panel to protect panel from damages.
6. Transparent electrodes may be disconnected if you use the LCD panel under environmental conditions where the condensation of dew occurs.
7. Do not leave module in direct sunlight to avoid malfunction of the ICs.

### 6.3. Static Electricity

1. Be sure to ground module before turning on power or operating module.
2. Do not apply voltage which exceeds the absolute maximum rating value.

### 6.4. Storage

1. Store the module in a dark room where must keep at  $25\pm 10^{\circ}\text{C}$  and 65%RH or less.
2. Do not store the module in surroundings containing organic solvent or corrosive gas.
3. Store the module in an anti-electrostatic container or bag.

### 6.5. Cleaning

1. Do not wipe the polarizer with dry cloth. It might cause scratch.
2. Only use a soft sloth with IPA to wipe the polarizer, other chemicals might permanent damage to the polarizer.

# 7. Mechanical Drawing

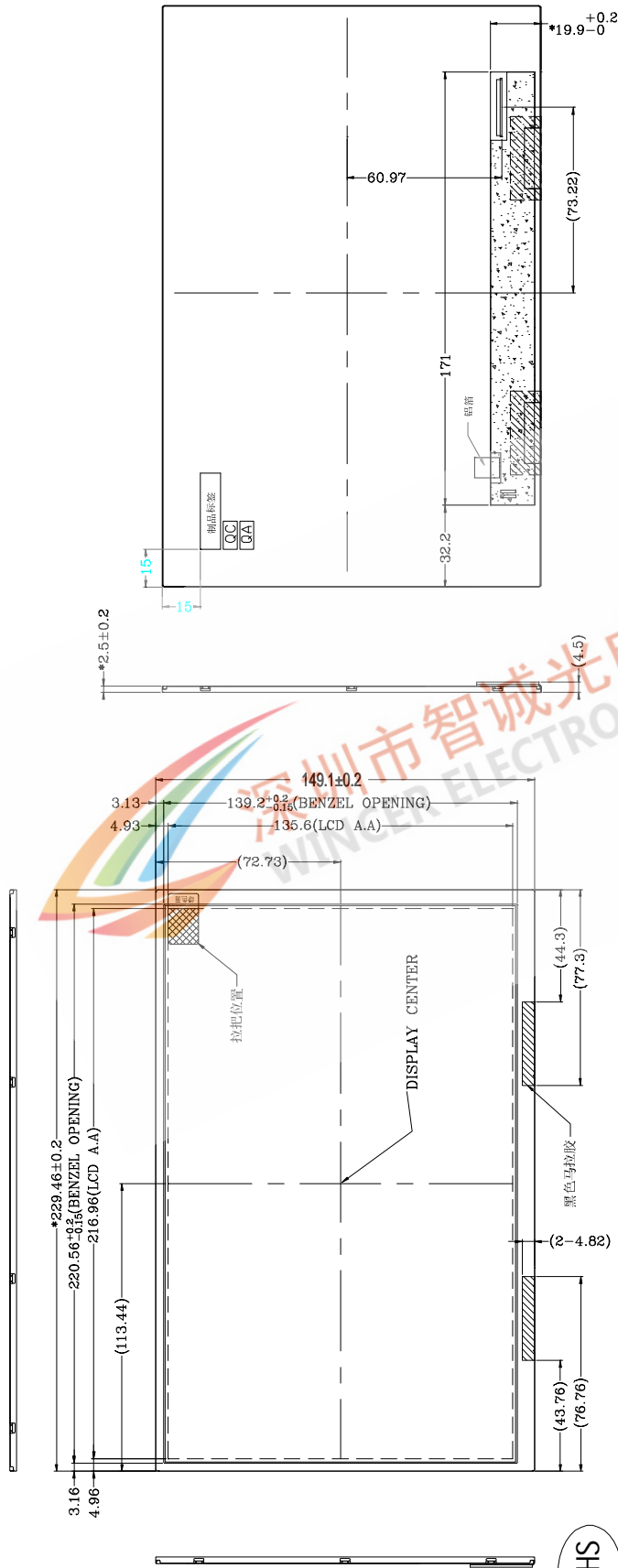

Notes:

1. Unit: mm
  2. Do not scale drawing.
  3. All radii without dimension R0.2
  4. Luminous intensity (9 AVG):  
350cd/m<sup>2</sup>(Min); 380cd/m<sup>2</sup>(Typ);  
5. Uniformity: 75%(Min)  
VF: 9V(Min); 9.9V(Typ); 10.5V(Max); IF: 260mA(FI)
  6. The color coordinates:
- |   | MIN  | TYP  | MAX  |
|---|------|------|------|
| X | 0.25 | 0.29 | 0.33 |
| Y | 0.28 | 0.32 | 0.36 |
7.  $\Delta$  Modification rev. number
  8. draft angle 1.0°
  9. General Tolerance:  $\pm 0.2$
  10. Mark mold cavity identification in recess approximately where indicated.
  11. "()" For important dimension; ( ) for reference dimension
  12. RoHS must be complied. (Use Lead-free process)

## 8. Package Drawing

### 8.1. Packaging Material Table

No.	Item	Model (Material)	Dimensions(mm)	Unit Weight (kg)	Quantity	Remark
1	LCM Module		229.46 × 149.1 × 2.5	0.150	40pcs	
8	Total weight	TBD ± 5%				

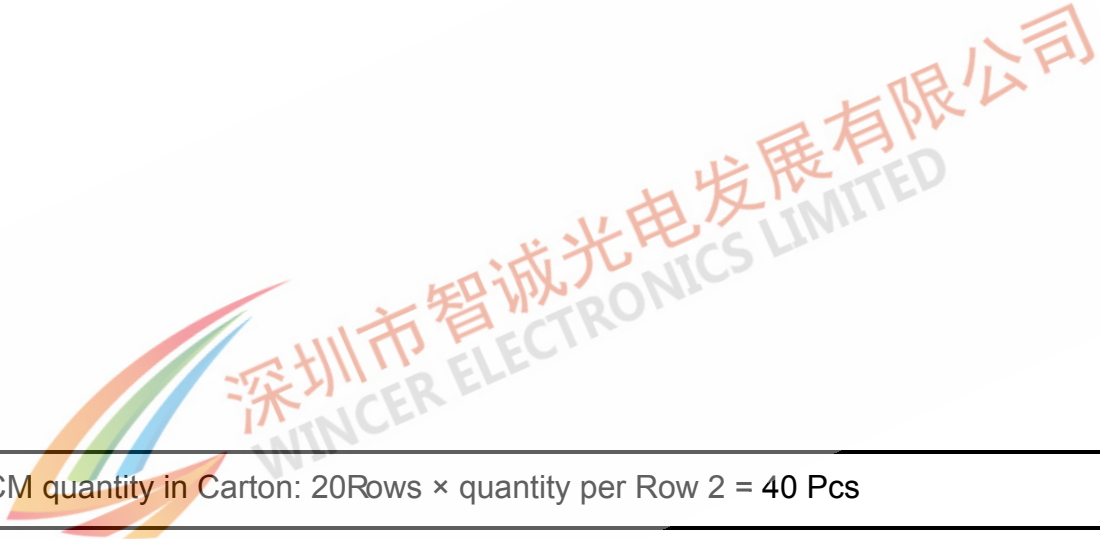

Total LCM quantity in Carton: 20Rows × quantity per Row 2 = 40 Pcs