

# 智诚光电有限公司

## INNOLUX8 寸 IPS 模组规格书 SPECIFICATION

承 认 印 Approved by	
审核:	确认:

客户确认结果:
---------

客 户: \_\_\_\_\_

品 名: ZÒ€ì €QĚ€FÖĞĚ ÉWÙÓVÚ

模组外形: 1ì H\*1l F\*í .5 mm

日 期: 2017.05.08

Approved 核 准	Checked 审 核	Prepared 制 作







3. 玻璃特性

Customer: \_\_\_\_\_  
Model Name: HE080IA-01D  
Date: 2012/07/14  
Version: 01

Preliminary Specification  
 Final Specification

For Customer's Acceptance

Approved by	Comment

Approved by	Reviewed by	Prepared by
STANLEY CW LEUNG	Wenyi Wang	Laurels.Yang
2012/08/06	2012/08/01	2012/07/14

### Record of Revision

Version	Revise Date	Page	Content
Pre-Spec.01	2011/07/14		Initial Release.



深圳市智诚光电发展有限公司  
WINNER ELECTRONICS LIMITED

# Contents

1. General Specifications .....	1
2. Pin Assignment .....	2
2.1. TFT LCD Panel Driving Section .....	2
3. Operation Specifications .....	5
3.1. Absolute Maximum Rating .....	5
3.1.1. Typical Operation Conditions .....	6
3.1.2. Current Consumption .....	7
3.2. Power Sequence .....	8
3.3. Timing Characteristics .....	9
3.3.1. AC Electrical Characteristics .....	9
3.3.2. Input Clock and Data Timing Diagram .....	9
3.3.3. DC Electrical Characteristics .....	10
3.3.4. Timing .....	11
3.3.5. Data Input Format .....	11
4. Optical Specifications .....	13
5. Reliability Test Items .....	17
6. General Precautions .....	18
6.1. Safety .....	18
6.2. Handling .....	18
6.3. Static Electricity .....	18
6.4. Storage .....	18
6.5. Cleaning .....	18
7. Mechanical Drawing .....	19
8. Package Drawing .....	20
8.1. Packaging Material Table .....	20
8.2. Packaging Quantity .....	20
8.3. Packaging Drawing .....	21

# 1. General Specifications

No.	Item	Specification	Remark
1	LCD size	8.0 inch(Diagonal)	
2	Driver element	a-Si TFT active matrix	
3	Resolution	1024 × 3(RGB) × 768	
4	Display mode	Normally Black	
5	Dot pitch	0.05275(W) × 0.15825(H) mm	
6	Active area	162.05(W) × 121.54(H) mm	
7	Panel size	171.12 (W) × 132.62 (H) × 1.07(D) mm	Note 1
8	Surface treatment	Hard coating	
9	Color arrangement	RGB-stripe	
10	Interface	Digital	
11	Panel power consumption	0.383W (Typ.)	
12	Weight	TBD	

Note 1: Refer to Mechanical Drawing.



## 2. Pin Assignment

### 2.1. TFT LCD Panel Driving Section

Pin No.	Symbol	I/O	Function	Remark
1	VCOM	P	Common Voltage	
2	VDD	P	Power Voltage for digital circuit	
3	VDD	P	Power Voltage for digital circuit	
4	NC	---	No connection	
5	Reset	I	Global reset pin	
6	STBYB	I	Standby mode, Normally pulled high STBYB = "1", normal operation STBYB = "0", timing controller, source driver will turn off, all output are High-Z	
7	GND	P	Ground	
8	RXIN0-	I	- LVDS differential data input	
9	RXIN0+	I	+ LVDS differential data input	
10	GND	P	Ground	
11	RXIN1-	I	- LVDS differential data input	
12	RXIN1+	I	+ LVDS differential data input	
13	GND	P	Ground	
14	RXIN2-	I	- LVDS differential data input	
15	RXIN2+	I	+ LVDS differential data input	
16	GND	P	Ground	
17	RXCLKIN-	I	- LVDS differential clock input	
18	RXCLKIN+	I	+ LVDS differential clock input	
19	GND	P	Ground	
20	RXIN3-	I	- LVDS differential data input	
21	RXIN3+	I	+ LVDS differential data input	
22	GND	P	Ground	
23	NC	---	No connection	
24	NC	---	No connection	

25	GND	P	Ground	
26	NC	---	No connection	
27	DIMO	O	Backlight CABC controller signal output	
28	SELB	I	6bit/8bit mode select	Note1
29	AVDD	P	Power for Analog Circuit	
30	GND	P	Ground	
31	LED-	P	LED Cathode	
32	LED-	P	LED Cathode	
33	L/R	I	Horizontal inversion	Note3
34	U/D	I	Vertical inversion	Note3
35	VGL	P	Gate OFF Voltage	
36	CABCEN1	I	CABC H/W enable	Note2
37	CABCEN0	I	CABC H/W enable	Note2
38	VGH	P	Gate ON Voltage	
39	LED+	P	LED Anode	
40	LED+	P	LED Anode	

I: input, O: output, P: Power

Note1: If LVDS input data is 6 bits ,SELB must be set to High;  
If LVDS input data is 8 bits ,SELB must be set to Low.

Note2: When CABC\_EN="00", CABC OFF.

When CABC\_EN="01", user interface image.

When CABC\_EN="10", still picture.

When CABC\_EN="11", moving image.

When CABC off, don't connect DIMO, else connect it to backlight.

Note3: When L/R="0", set right to left scan direction.

When L/R="1", set left to right scan direction.

When U/D="0", set top to bottom scan direction.

When U/D="1", set bottom to top scan direction.

Note: Definition of scanning direction.  
Refer to the figure as below:

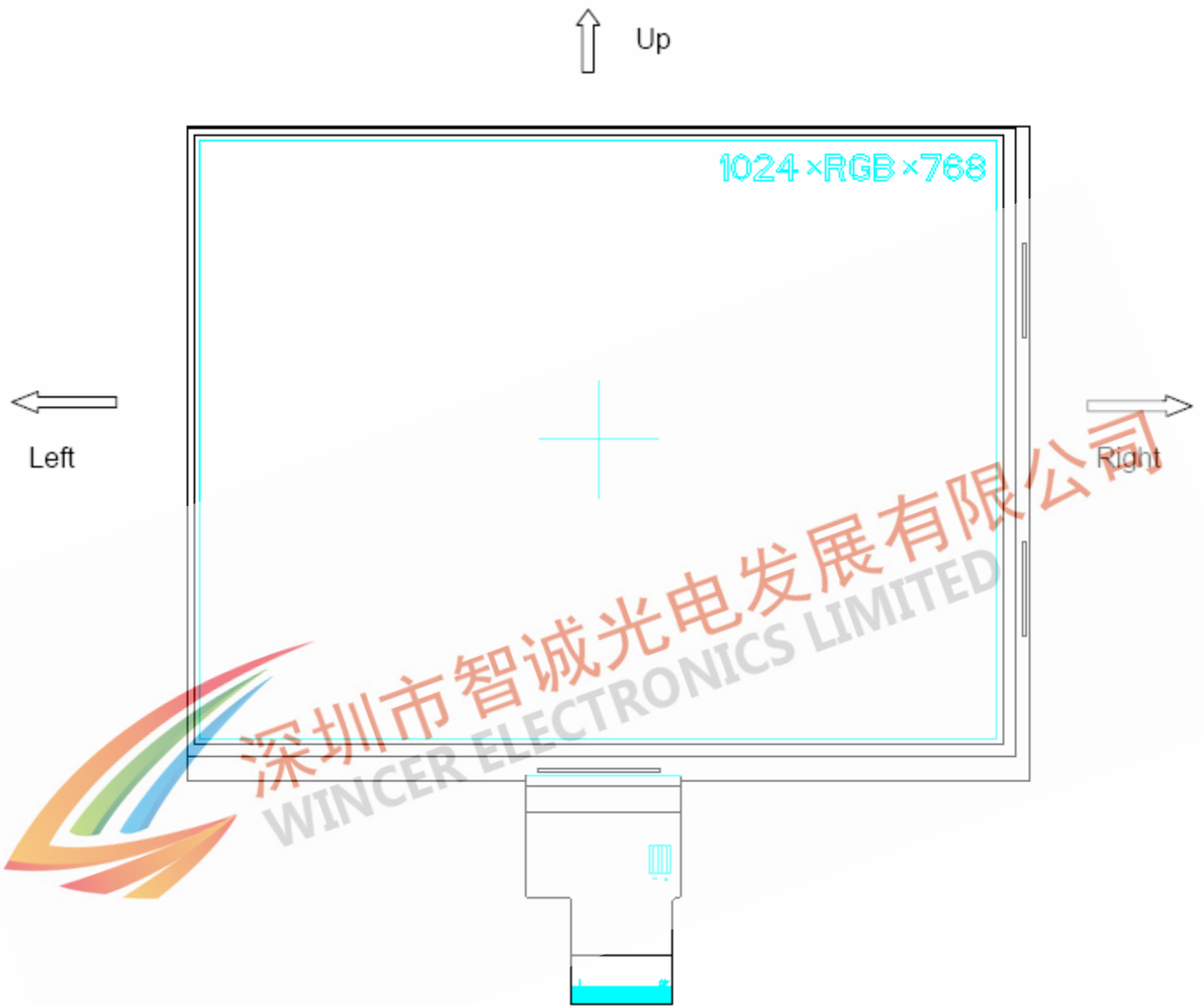

## 3. Operation Specifications

### 3.1. Absolute Maximum Rating

(GND=AV<sub>SS</sub>=0V, Note 1)

Item	Symbol	Values		Unit	Remark
		Min.	Max.		
Power voltage	V <sub>CC</sub>	-0.3	5.0	V	
	AV <sub>DD</sub>	6.5	13.5	V	
	V <sub>GH</sub>	-0.3	40	V	
	V <sub>GL</sub>	-20	0.3	V	
	V <sub>GH</sub> -V <sub>GL</sub>	-	40	V	
Operation Temperature Storage Temperature	T <sub>OP</sub>	-20	70	°C	
	T <sub>ST</sub>	-30	70	°C	

Note 1: The absolute maximum rating values of this product are not allowed to be exceeded at any times. Should a module be used with any of the absolute maximum ratings exceeded, the characteristics of the module may not be recovered, or in an extreme case, the module may be permanently destroyed.

### 3.1.1. Typical Operation Conditions

(GND=AV<sub>SS</sub>=0V, Note 1)

Item	Symbol	Values			Unit	Remark
		Min.	Typ.	Max.		
Power voltage	V <sub>CC</sub>	3.0	3.3	3.6	V	Note 2
	AV <sub>DD</sub>	9.8	10	10.2	V	
	V <sub>GH</sub>	18.6	18.9	19.2	V	
	V <sub>GL</sub>	-8.1	-7.8	-7.5	V	
Input signal voltage	V <sub>COM</sub>	2.6	3.6	4.6	V	Note 3
Input logic high voltage	V <sub>IH</sub>	0.7V <sub>CC</sub>	-	V <sub>CC</sub>	V	Note 4
Input logic low voltage	V <sub>IL</sub>	0	-	0.3V <sub>CC</sub>	V	

- Note 1: Be sure to apply V<sub>CC</sub> and V<sub>GL</sub> to the LCD first, and then apply V<sub>GH</sub>.
- Note 2: V<sub>CC</sub> setting should match the signals output voltage (refer to Note 3) of customer's system board.
- Note 3: Typical V<sub>com</sub> is only a reference value, it must be optimized according to each LCM, please use VR and base on below application circuit.
- Note 4: RESET, STBYB, SELB, L/R, UID, CABSEN0, CABSEN1.

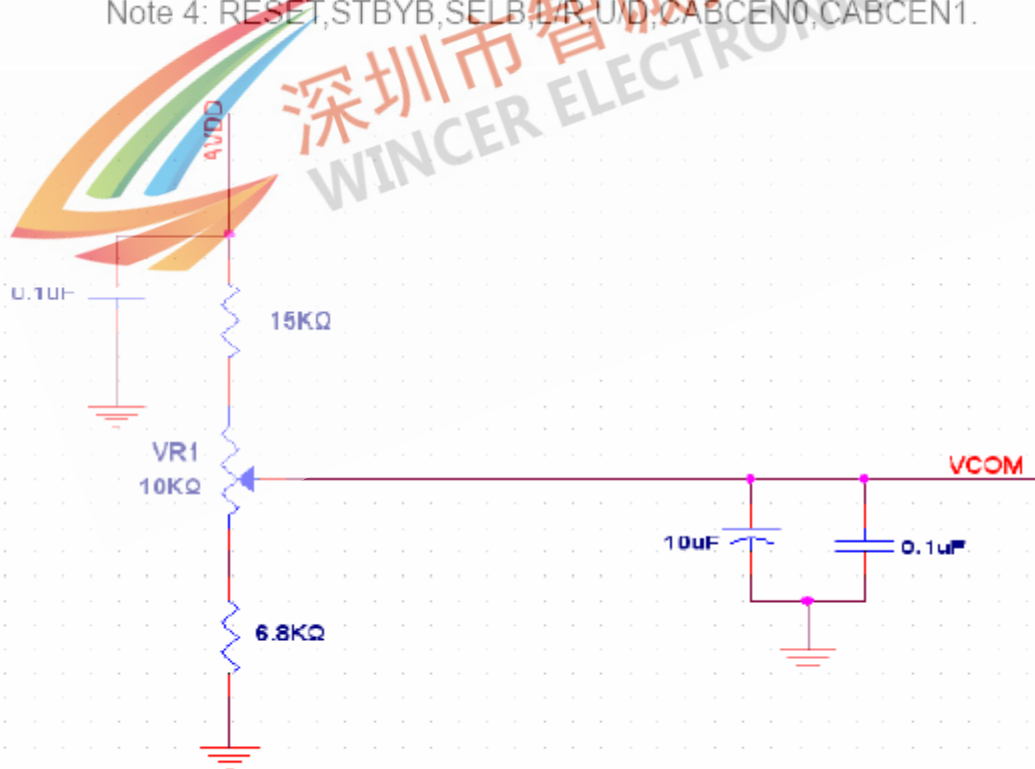

### 3.1.2. Current Consumption

(GND=AV<sub>SS</sub>=0V)

Item	Symbol	Values			Unit	Remark
		Min.	Typ.	Max.		
Current for Driver	I <sub>GH</sub>	-	0.65	1.0	mA	V <sub>GH</sub> =18.9V
	I <sub>GL</sub>	-	0.65	1.0	mA	V <sub>GL</sub> =-7.8V
	I <sub>CC</sub>	-	35	60	mA	V <sub>CC</sub> =3.3V
	I <sub>AVDD</sub>	-	25	40	mA	AV <sub>DD</sub> =10.0V



## 3.2. Power Sequence

### 3.2.1. Power on:

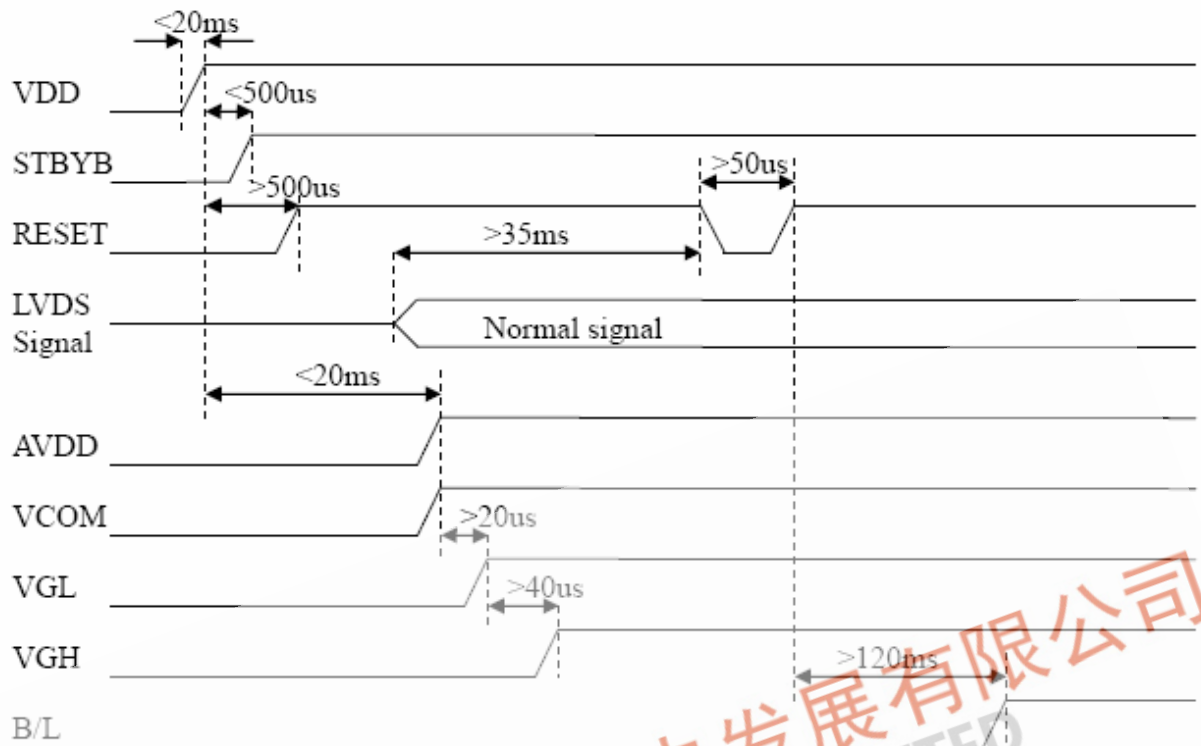

### 3.2.2. Power off:

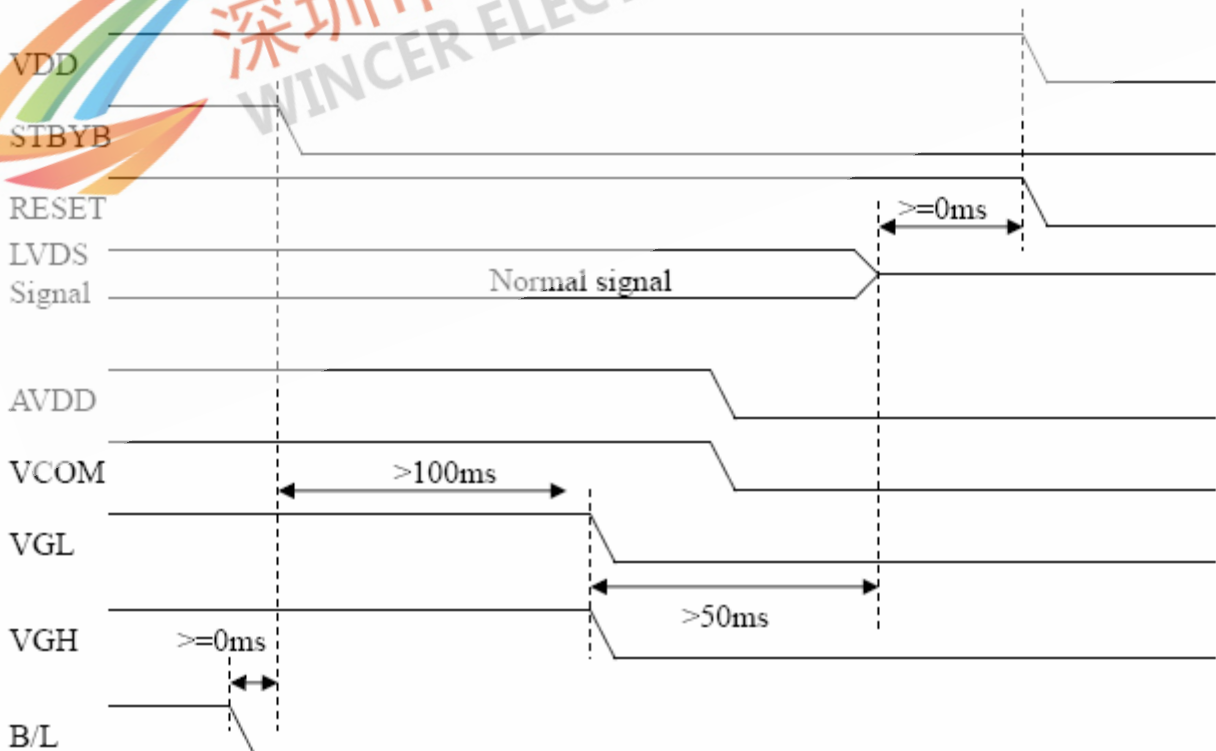



### 3.3. Timing Characteristics

#### 3.3.1. AC Electrical Characteristics

Parameter	Symbol	Values			Unit	Remark
		Min.	Typ.	Max.		
Clock frequency	$R_{XFCLK}$	20	-	71	MHz	
Input data skew margin	$T_{RSKM}$	500	-	-	ps	
Clock high time	$T_{LVCH}$	-	$4/(7 * R_{XFCLK})$	-	ns	
Clock low time	$T_{LVCL}$	-	$3/(7 * R_{XFCLK})$	-	ns	

#### 3.3.2. Input Clock and Data Timing Diagram

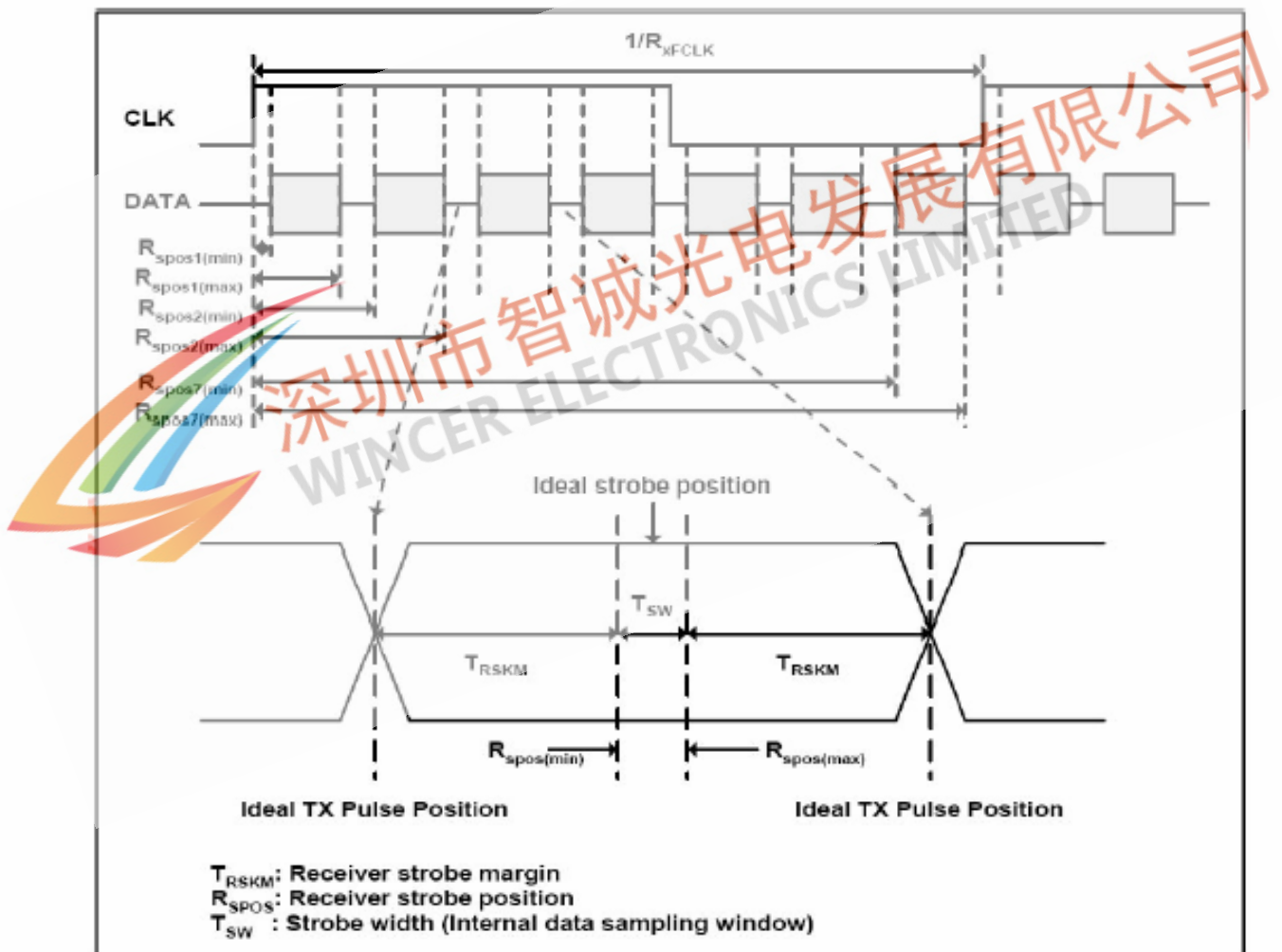



### 3.3.3. DC Electrical Characteristics

Parameter	Symbol	Values			Unit	Remark
		Min.	Typ.	Max.		
Differential input high Threshold voltage	$R_{xVTH}$	-	-	+0.1	V	
Differential input low Threshold voltage	$R_{xVTL}$	-0.1	-	-	V	
Input voltage range (singled-end)	$R_{xVIN}$	0	-	2.4	V	
Differential input common mode voltage	$R_{xVCM}$	$ V_{ID} /2$	-	$2.4- V_{ID} /2$	V	
Differential voltage	$ V_{ID} $	0.2	-	0.6	V	
Differential input leakage current	$R_{V_{xIz}}$	-10	-	+10	$\mu A$	

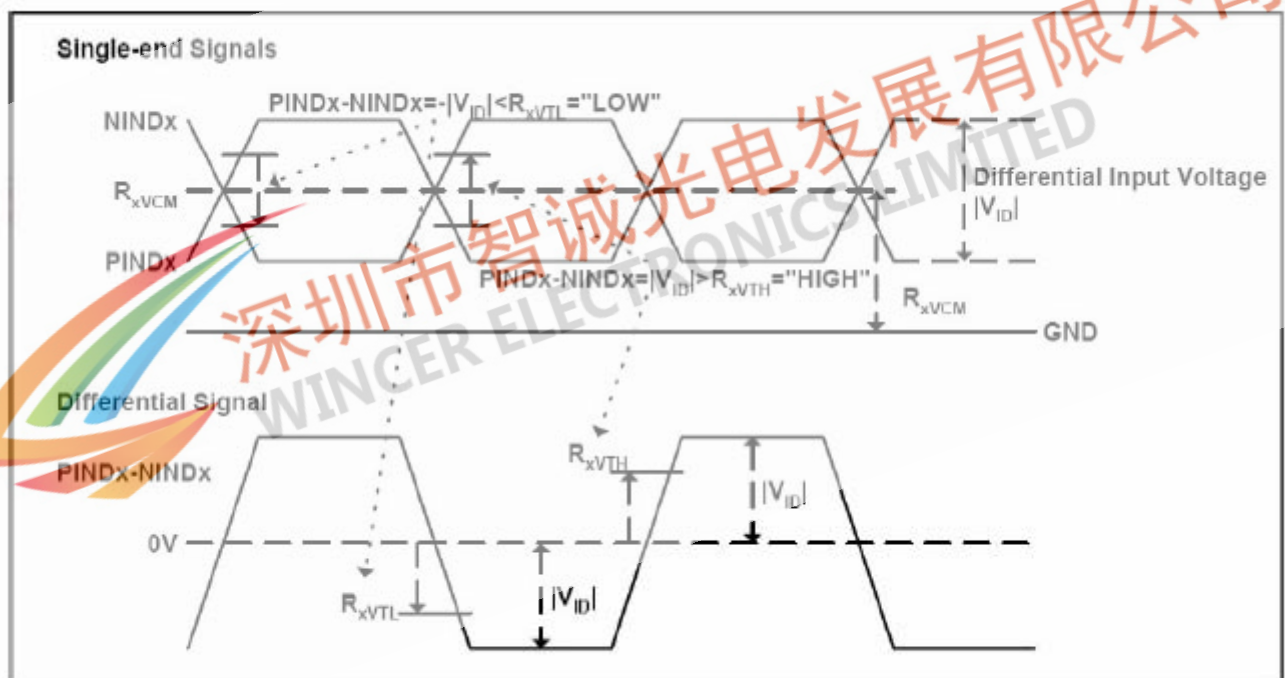

### 3.3.4. Timing

Item	Symbol	Values			Unit	Remark
		Min.	Typ.	Max.		
Clock Frequency	fclk	52	65	71	MHz	Frame rate =TBD
Horizontal display area	thd	1024				
HS period time	th	1114	1344	1400	DCLK	
HS Blanking	thb+thfp	90	320	376	DCLK	
Vertical display area	tvd	768				
VS period time	tv	778	806	845	H	
VS Blanking	tvb+tvfp	10	38	77	H	

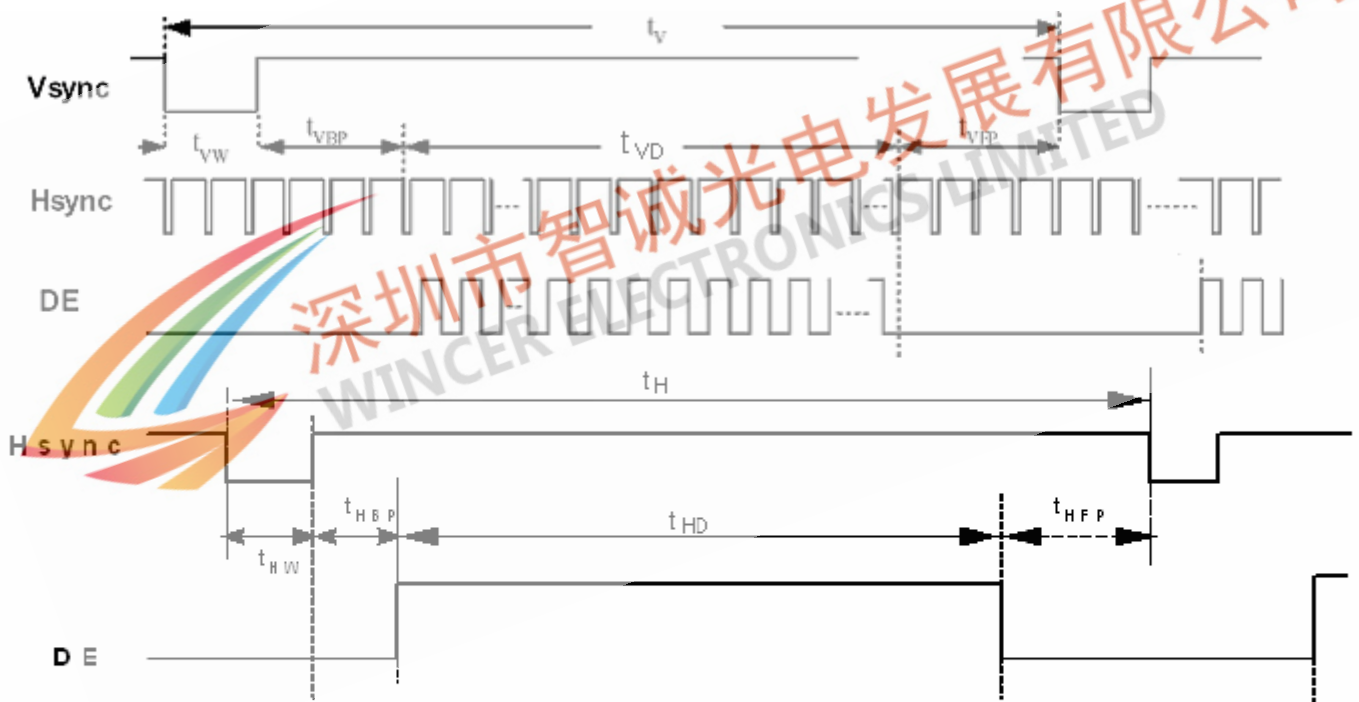

### 3.3.5. Data Input Format

#### 6bit LVDS input

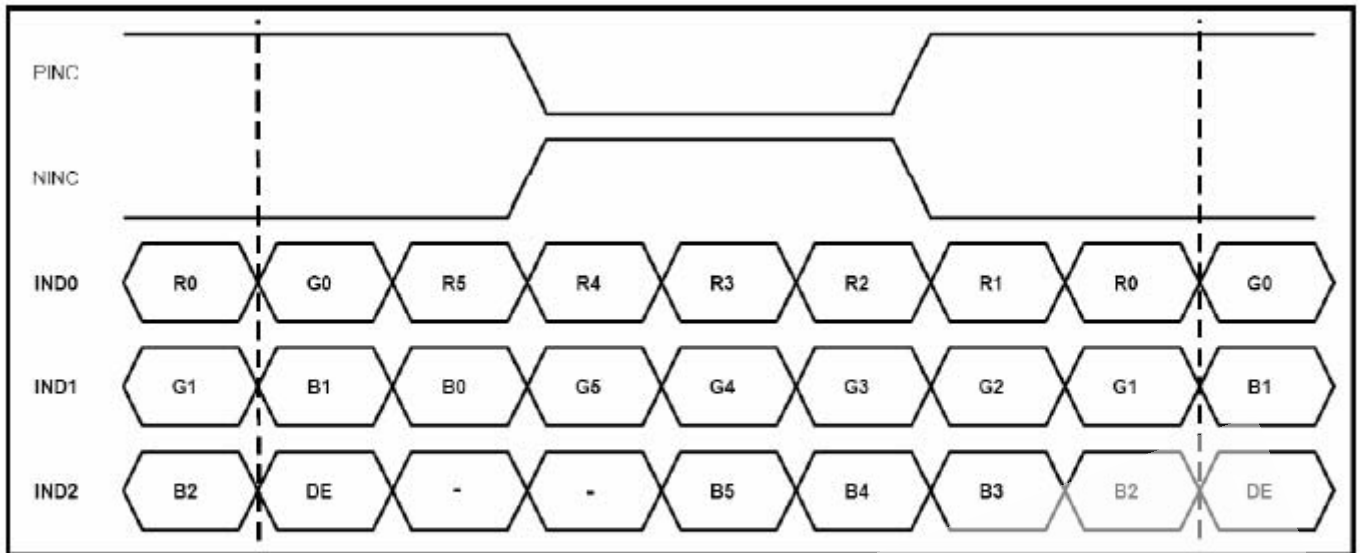

### 8bit LVDS input

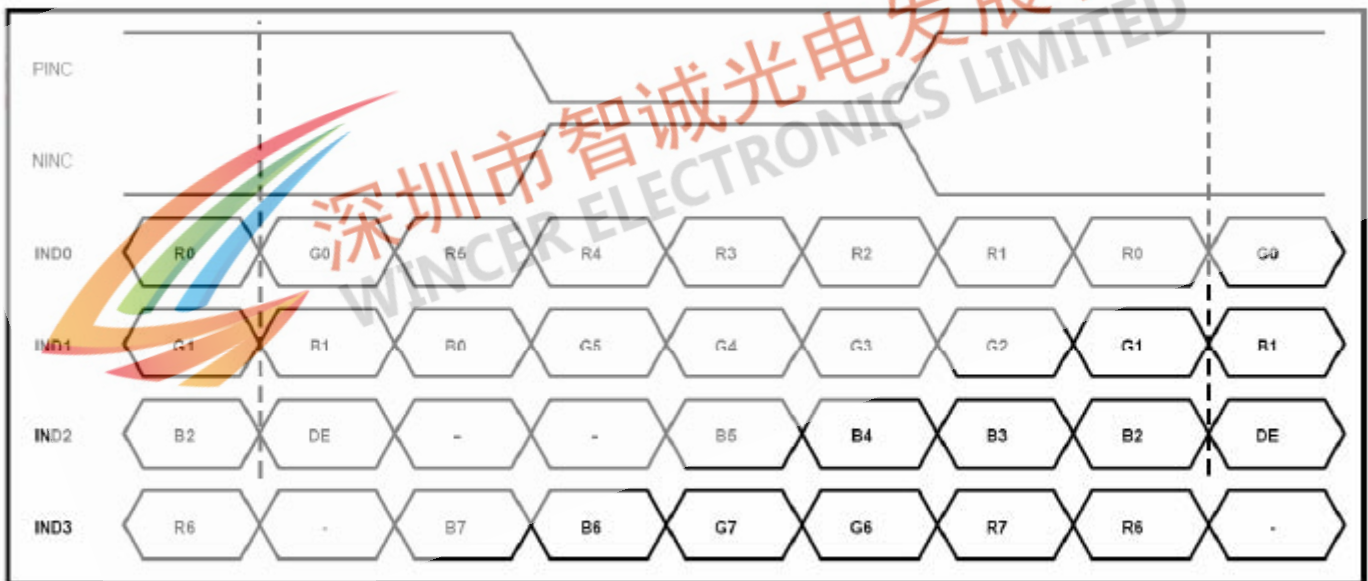

Note: Support DE timing mode only, SYNC mode not supported.

## 4. Optical Specifications

Item	Symbol	Condition	Values			Unit	Remark
			Min.	Typ.	Max.		
Viewing angle (CR≥ 10)	$\theta_L$	$\Phi=180^\circ$ (9 o'clock)	75	85	-	degree	Note 1
	$\theta_R$	$\Phi=0^\circ$ (3 o'clock)	75	85	-		
	$\theta_T$	$\Phi=90^\circ$ (12 o'clock)	75	85	-		
	$\theta_B$	$\Phi=270^\circ$ (6 o'clock)	75	85	-		
Response time	$T_{ON+T_{OFF}}$	Normal $\theta=\Phi=0^\circ$		25	50	msec	Note 2 Note 3
Contrast ratio	CR		600	800	-	-	Note 4
Color chromaticity	$W_X$		0.238	0.288	0.338	-	Note 5
	$W_Y$		0.276	0.326	0.376	-	
Transmittance	Tr		3.8	4.3	-	%	

Test Conditions:

1.  $V_{CC}=3.3V$ , the ambient temperature is  $25^\circ C$ .
2. The test systems refer to Note 2.

Note 1: Definition of viewing angle range

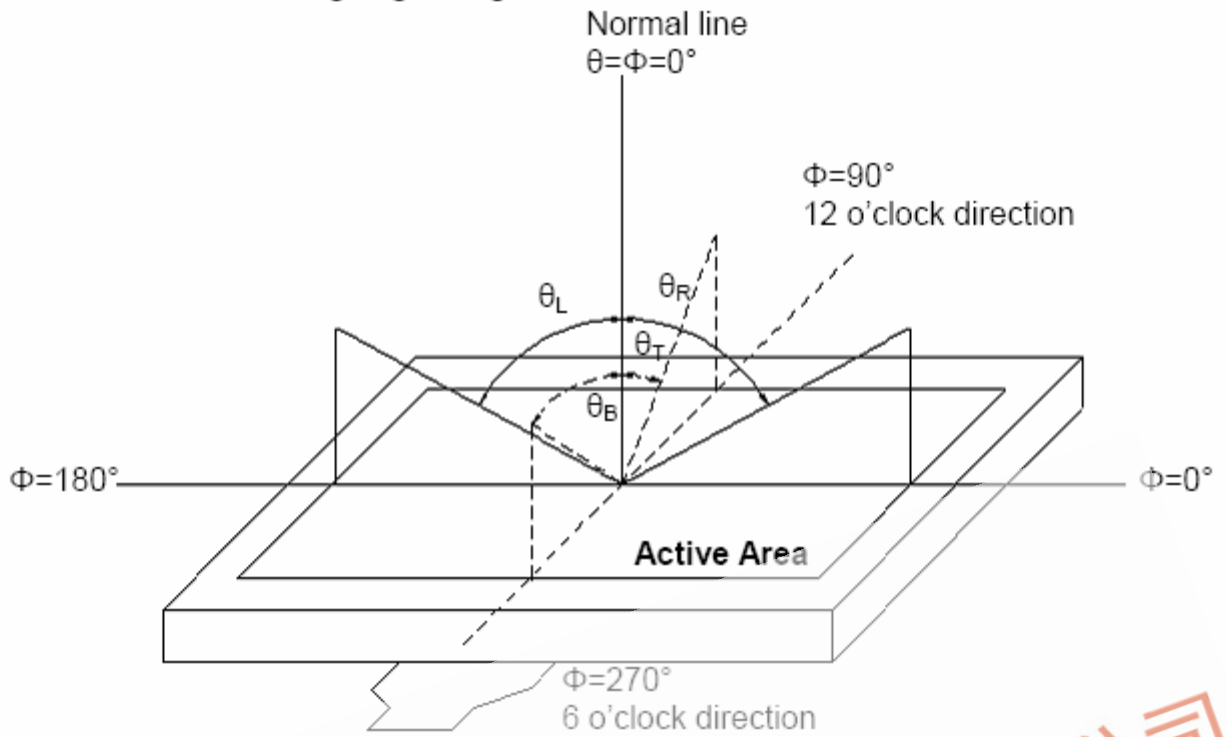

Fig. 4-1 Definition of viewing angle

Note 2: Definition of optical measurement system.

The optical characteristics should be measured in dark room. After 30 minutes operation, the optical properties are measured at the center point of the LCD screen. (Viewing angle is measured by EIDIM-EZ contrast/Height :1.2mm, Response time is measured by Photo detector TOPCON BM-7, other items are measured by BM-5A/ Field of view: 1 /Height: 500mm.)

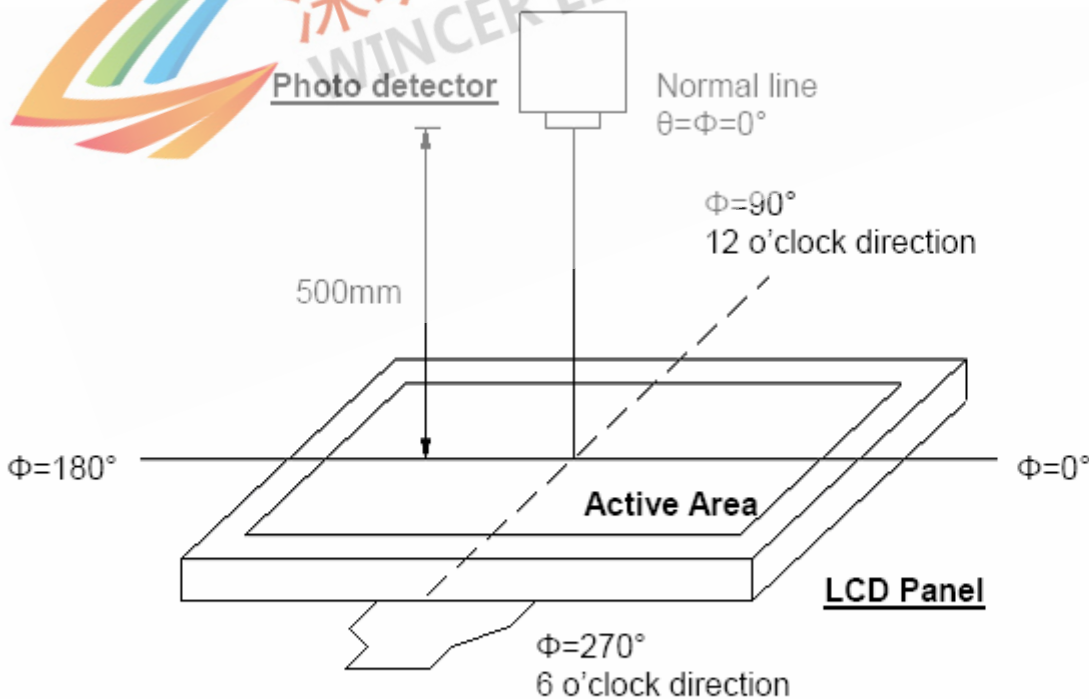

Fig. 4-2 Optical measurement system setup

Note 3: Definition of Response time

The response time is defined as the LCD optical switching time interval between "White" state and "Black" state. Rise time ( $T_{ON}$ ) is the time between photo detector output intensity changed from 90% to 10%. And fall time ( $T_{OFF}$ ) is the time between photo detector output intensity changed from 10% to 90%.

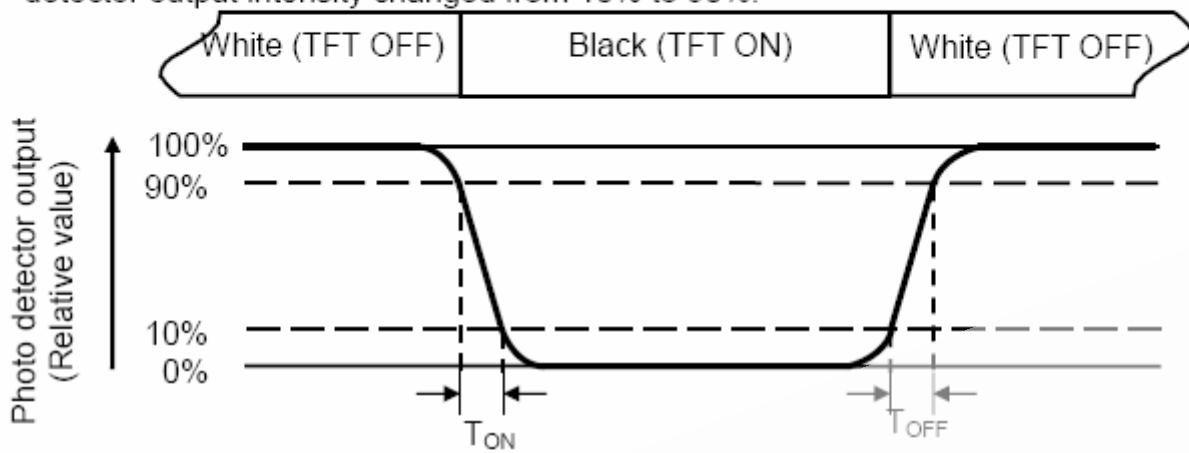

Fig. 4-3 Definition of response time

Note 4: Definition of contrast ratio

$$\text{Contrast ratio (CR)} = \frac{\text{Luminance measured when LCD on the "White" state}}{\text{Luminance measured when LCD on the "Black" state}}$$

Note 5: Definition of backlight

The backlight used C light.

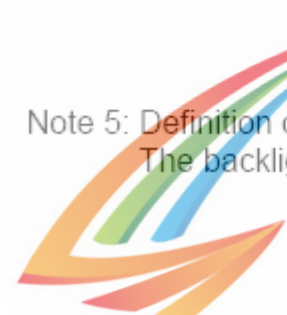

深圳市智诚光电发展有限公司  
WINNER ELECTRONICS LIMITED

Note 7: Definition of Luminance Uniformity

Active area is divided into 9 measuring areas (Refer to Fig. 4-4 ).Every measuring point is placed at the center of each measuring area.

$$\text{Luminance Uniformity (Yu)} = \frac{B_{\min}}{B_{\max}}$$

L-----Active area length      W----- Active area width

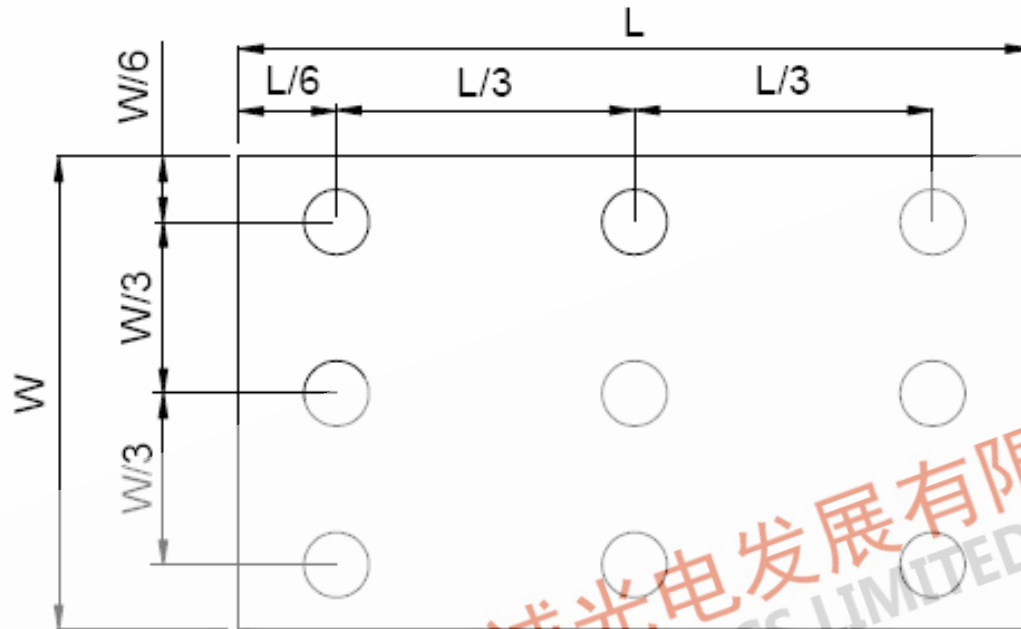

Fig. 4-4 Definition of measuring points

$B_{\max}$ : The measured maximum luminance of all measurement position.

$B_{\min}$ : The measured minimum luminance of all measurement position.



## 5. Reliability Test Items

(Note3)

Item	Test Conditions		Remark
High Temperature Storage	Ta = 60°C	240hrs	Note 1, Note 4
Low Temperature Storage	Ta = -20°C	240hrs	Note 1, Note 4
High Temperature Operation	Ts = 50°C	240hrs	Note 2, Note 4
Low Temperature Operation	Ta = -10°C	240hrs	Note 1, Note 4
Operate at High Temperature and Humidity	Ta=40°C    H=90%RH	240hrs	Note 4

Note 1: Ta is the ambient temperature of samples.

Note 2: Ts is the temperature of panel's surface.

Note 3: In the standard condition, there shall be no practical problem that may affect the display function. After the reliability test, the product only guarantees operation, but don't guarantee all of the cosmetic specification.

Note 4: Before cosmetic and function test, the product must have enough recovery time, at least 2 hours at room temperature.



深圳市智诚光电发展有限公司  
WINNER ELECTRONICS LIMITED



## 6. General Precautions

### 6.1. Safety

Liquid crystal is poisonous. Do not put it in your mouth. If liquid crystal touches your skin or clothes, wash it off immediately by using soap and water.

### 6.2. Handling

1. The LCD panel is plate glass. Do not subject the panel to mechanical shock or to excessive force on its surface.
2. The polarizer attached to the display is easily damaged. Please handle it carefully to avoid scratch or other damages.
3. To avoid contamination on the display surface, do not touch the module surface with bare hands.
4. Keep a space so that the LCD panels do not touch other components.
5. Put cover board such as acrylic board on the surface of LCD panel to protect panel from damages.
6. Transparent electrodes may be disconnected if you use the LCD panel under environmental conditions where the condensation of dew occurs.
7. Do not leave module in direct sunlight to avoid malfunction of the ICs.

### 6.3. Static Electricity

1. Be sure to ground module before turning on power or operating module.
2. Do not apply voltage which exceeds the absolute maximum rating value.

### 6.4. Storage

1. Store the module in a dark room where must keep at  $25\pm 10^{\circ}\text{C}$  and 65%RH or less.
2. Do not store the module in surroundings containing organic solvent or corrosive gas.
3. Store the module in an anti-electrostatic container or bag.

### 6.5. Cleaning

1. Do not wipe the polarizer with dry cloth. It might cause scratch.
2. Only use a soft sloth with IPA to wipe the polarizer, other chemicals might permanent damage to the polarizer.

## 7. Mechanical Drawing

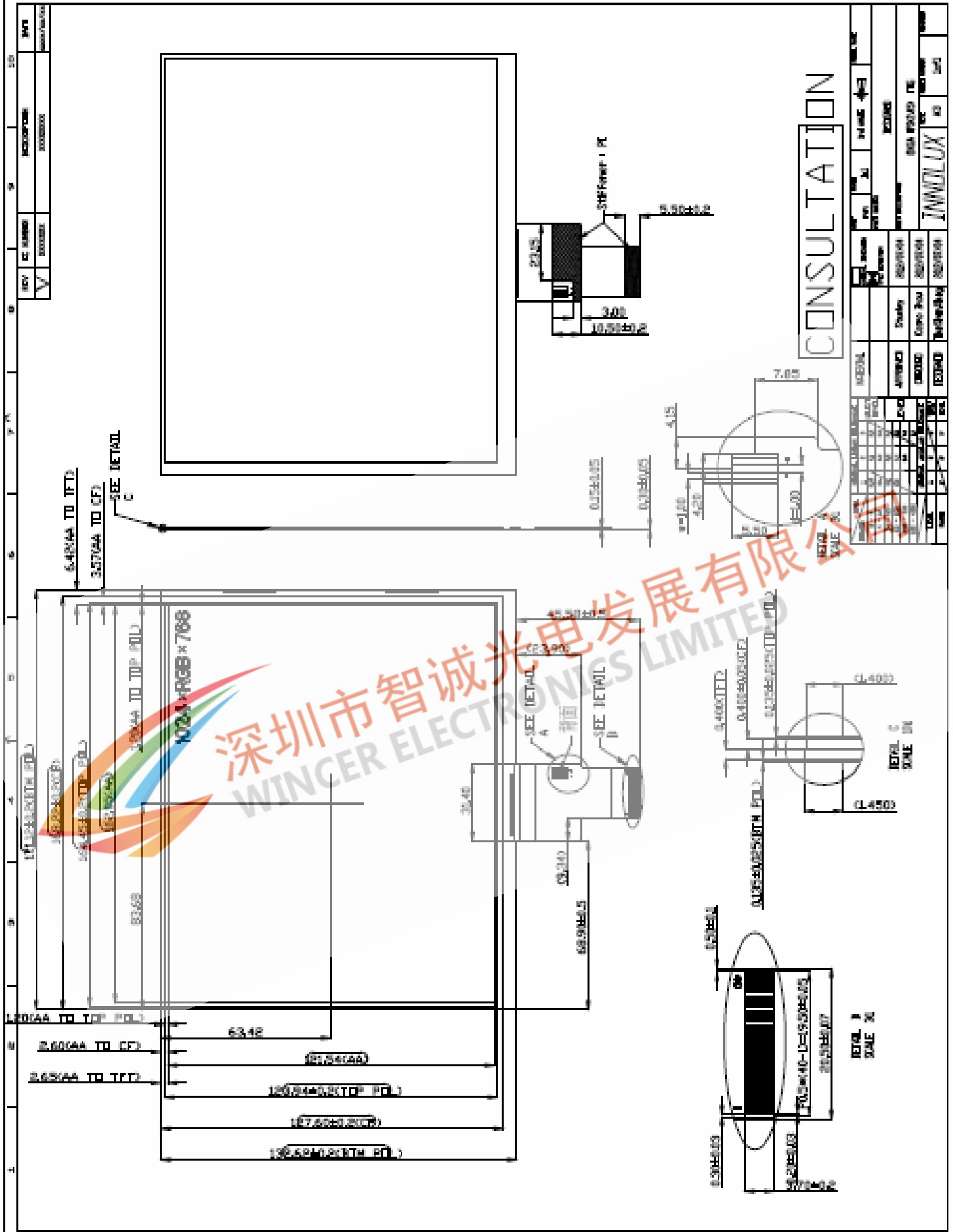

# CONSULTATION

REV	IC NUMBER	DESCRIPTION	DATE												
V	0000001	00000001	00000001												
<table border="1"> <tr> <th>NO.</th> <th>REV.</th> <th>DATE</th> <th>BY</th> <th>CHK.</th> <th>APP.</th> </tr> <tr> <td>1</td> <td>1</td> <td>2017.05.08</td> <td>W</td> <td>W</td> <td>W</td> </tr> </table>				NO.	REV.	DATE	BY	CHK.	APP.	1	1	2017.05.08	W	W	W
NO.	REV.	DATE	BY	CHK.	APP.										
1	1	2017.05.08	W	W	W										
DRAWING NO.		DATE	SCALE												
0000001		2017.05.08	1:1												
DRAWING TITLE		DATE	SCALE												
CONSULTATION		2017.05.08	1:1												
DRAWING NO.		DATE	SCALE												
0000001		2017.05.08	1:1												
DRAWING TITLE		DATE	SCALE												
CONSULTATION		2017.05.08	1:1												

## 8.1 Packaging Material Table

No	Item	Model (Material)	Dimensions(mm)	Unit Weight (Kg)	Quantity (pcs)	Remark
1	Panel size	HE080IA-01D	171.12×132.62×1.07	TBD	60	
2	Partition	BC Corrugated Paper	512 × 350 × 225	0.290	1	
3	Dust-Proof Bag	PE	700 × 530	0.050	1	
4	PET-Tray	PE	505 × 338 × 16.5	0.24	21	
5	Carton	Corrugated Paper	530 × 355 × 255	0.810	1	
6	Total weight	9.346KG±5%				

## 8.2 Packaging Quantity

(1) FOG quantity per PET-Tray: row x pcs = 3pcs

(2) Total FOG quantity in Carton: layer x pcs/PET-Tray = 60 pcs



深圳市智诚光电发展有限公司  
WINNER ELECTRONICS LIMITED

### 8.3 Packaging Drawing



### 3. 2测定条件

在无特别指定条件下，产品于温度  $25 \pm 2^{\circ}\text{C}$ ，湿度  $60 \pm 10\%$ 环境条件进行测试。

### 4. 品质要求

#### 4. 1 光学特性

项目	符号	条件	规格			单位	备注
			Min	Typ	Max		
均匀度	$\Delta I$	面内九点	70	75	-	%	
色度	X	中心点	--		--		
	Y	中心点	--		--		
模组亮度	I	中心点		300	-	cd/m <sup>2</sup>	

注 1：表内测定点规格需在发光条电流(220)mA，周围环境温度  $25 \pm 2^{\circ}\text{C}$ 测试。

注 2：测试条件：1) 以规定的电流电压正常点亮；

2) 测试环境：暗室（10Lux 以下）

3) 辉度、色坐标测试点：见下图

4) 光学特性测试点图

注 3：均匀性  $\Delta I = (I_{\text{MIN}} \div I_{\text{MAX}}) \times 100\%$

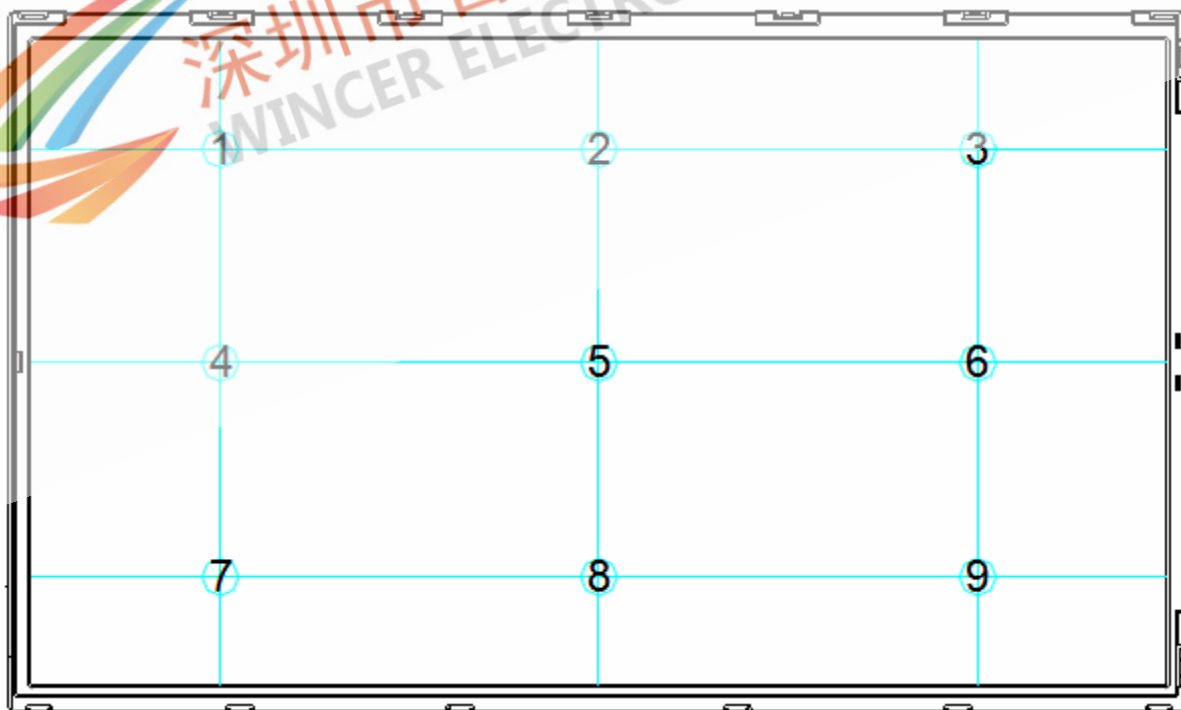

## 4. 2 电气特性

### 4. 2. 1 LED电性规格

项目	符号	条件	规格			单位	备注
			Min	Typ	Max		
LED电流	I <sub>L</sub>	常温25℃	-	220	-	mA	
LED电压	V <sub>L</sub>	常温25℃	2.7	3.2	3.6	V	I <sub>L</sub> =20mA
点亮延迟到	TD	注2				sec	

注1: LED点亮电流不可超过最大电流限定值, 否则LED寿命和亮度将会受到严重影响。  
注2: 点亮测试延迟时间: ON 30sec--OFF 30sec

### 4. 2. 2 LED灯条适用电性规格

项目	符号	条件	规格			单位	备注
			Min	Typ	Max		
灯条电压	V <sub>L</sub>	常温25℃	8.1	9.6	10.8	Vrms	I <sub>L</sub> =220mA
灯条电流	I <sub>L</sub>	常温25℃		220		mArms	
点亮功率	W <sub>L</sub>	常温25℃			(3.56)	Wrms	I <sub>L</sub> =330mA

注1: 灯条点亮功率需在要求范围以内。

## 4. 3 产品寿命

周围温度+25℃±2℃, 湿度 60±20%RH, 以每灯 20mA 工作电流之推荐使用条件, 背光源之寿命为:

辉度减半平均寿命: 30,000 小时以上

辉度减半保证寿命: 20,000 小时以上

注: 辉度减半平均寿命指背光源平均辉度衰减到初期平均辉度的 50%所需时间。



PIN	定义
1	GND
2	D+
3	D-
4	VDD

正视图

侧视图

背视图

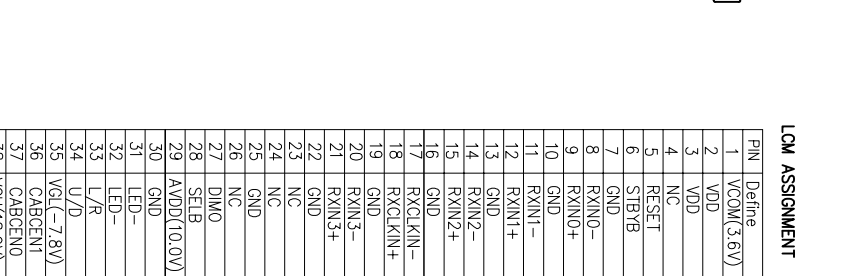
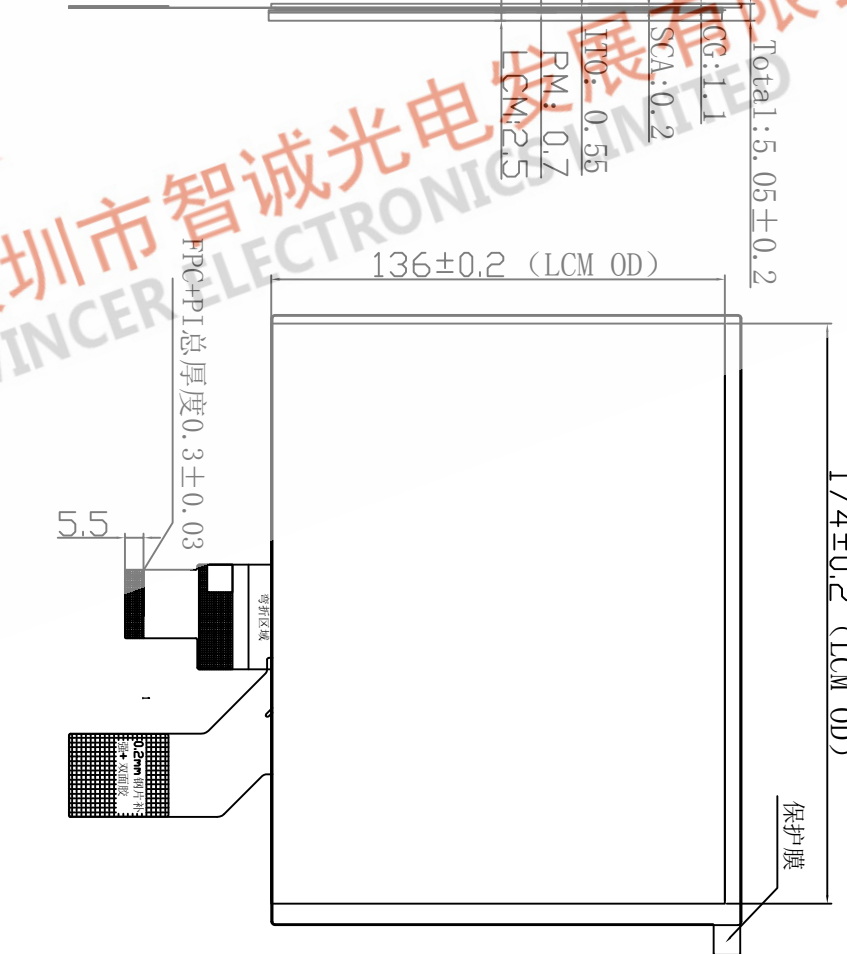
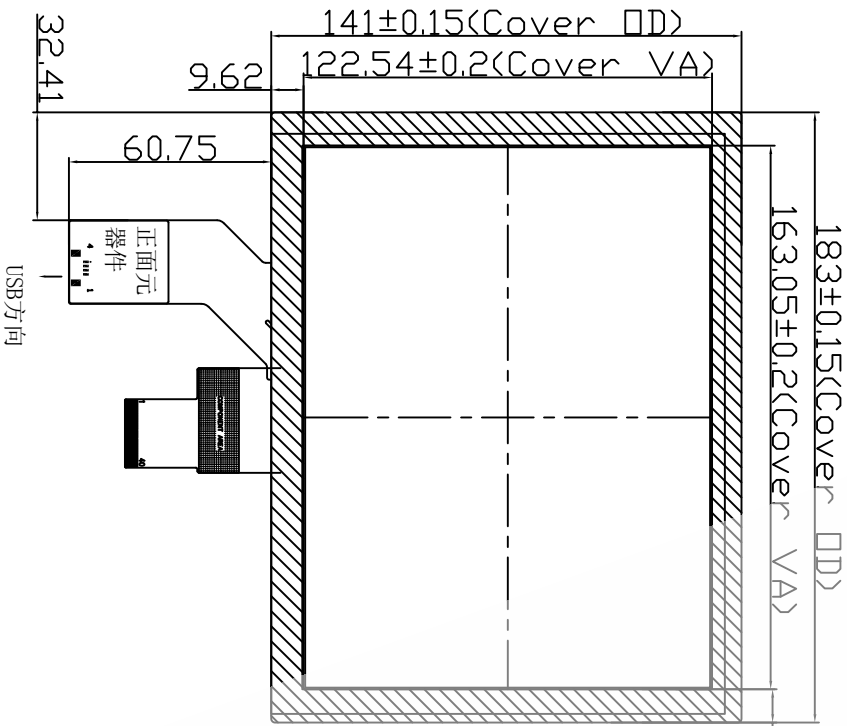

LCM ASSIGNMENT

PIN	Define
1	VCOM(3.6V)
2	VDD
3	VDD
4	VDD
5	NC
6	RESET
7	STBYB
8	GND
9	RXIN0+
10	RXIN0-
11	GND
12	RXIN1+
13	RXIN1-
14	GND
15	RXIN2+
16	RXIN2-
17	GND
18	RXCCLKIN-
19	RXCCLKIN+
20	GND
21	RXIN3+
22	RXIN3-
23	GND
24	NC
25	NC
26	GND
27	NC
28	DIM0
29	SELB
30	AVDD(10.0V)
31	GND
32	LED-
33	LED+
34	L/R
35	U/D
36	VO(-7.8V)
37	CABCENT
38	NC
39	VB(18.9V)
40	LED+

备注:

1. USB通讯, 驱动IC: ILI2511, CG材料: 旭硝子 (钢化)
2. 透光率:  $\geq 88\%$  VDD: 5.0V
3. 工作温度:  $-10^{\circ}\text{C} \sim +60^{\circ}\text{C}$ ,  $\leq 90\% \text{RH}$
4. 储存温度:  $-20^{\circ}\text{C} \sim +70^{\circ}\text{C}$ ,  $\leq 90\% \text{RH}$
5. 跌落测试: 钢球重量110g, 高度20cm, 表面硬度:  $\geq 6\text{H}$
6. 未标尺寸公差 $\pm 0.2 \text{ mm}$ , 带\*为关键尺寸
7. 所用材料必须符合欧盟2011/65/EU (RoHS) 标准:

For Customer:

Approval Date:

Approved by:

Please Confirm This Drawing On/Before

智诚光电		WINCER ELECTRONIC LIMITED	
第三角法	品名	CTP	MATERIAL
UNIT	PART NO.	GY09G080	DATE
mm	EDITION	V1	2020.05.24
mm	版本	V1	PAGE
			1-1
			DESIGN
			LXQ
			视窗整体上移0.39mm

